

TPS54200, TPS54201 4.5-V to 28-V Input Voltage, 1.5-A Output Current, Synchronous Buck Mono-Color or IR LED Driver

1 Features

- 4.5-V to 28-V Wide Input Range
- Integrated 150-m Ω and 70-m Ω MOSFETs for 1.5-A, Continuous Output Current
- Low, 2- μ A Shutdown Current
- Fixed 600-kHz Frequency
- Peak Current Mode With Internal Compensation
- 200-mV and 100-mV Sense Voltage During Analog and PWM Dimming Modes
- Precision Analog Dimming (ADIM) by PWM Input
- LED-Open and -Short Protection
- Sense-Resistor-Open and -Short Protection
- Shutdown-and-Latch Mode Protection (TPS54200)
- Auto-Retry Mode Protection (TPS54201)
- Thermal Shutdown
- 6-Pin SOT-23-THIN Package

2 Applications

- IR LED for Day or Night Vision
 - IP Network Camera
 - Analog Security Camera
 - Video Doorbell
 - Embedded Camera System
- LED Display and Lighting
 - Refrigerators and Freezers
 - Electronic Smart Lock
 - General-Purpose LED Driver
 - Architecture Lighting

3 Description

The TPS54200 and TPS54201 devices are 1.5-A synchronous buck mono-color or IR drivers with 28-V maximum input voltage. Current-mode operation provides fast transient response and eases loop stabilization.

The TPS54200 and TPS54201 can be used to drive single-string or multi-string mono-color or Infrared (IR) LED arrays as in the case of night vision cameras.

By integrating the MOSFETs and employing the SOT-23-THIN package, the TPS54200 and TPS54201 devices provide high power density and only require a small footprint on the PCB.

The TPS54200 and TPS54201 devices implement analog dimming by changing the internal reference voltage proportional to the duty cycle of the PWM signal input in analog dimming mode. This devices also support PWM dimming mode, in which the internal reference voltage is halved to 100 mV for higher efficiency.

Device Information⁽¹⁾

PART NUMBER	PACKAGE	BODY SIZE (NOM)
TPS54200	SOT-23-THIN (6)	1.6 mm x 2.9 mm
TPS54201	SOT-23-THIN (6)	1.6 mm x 2.9 mm

(1) For all available packages, see the orderable addendum at the end of the data sheet.

Simplified Schematic

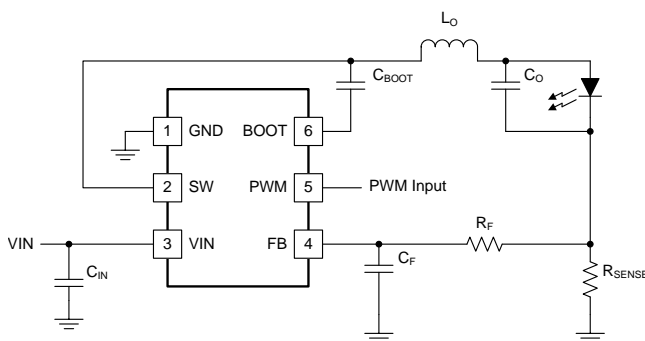

Copyright © 2016, Texas Instruments Incorporated

Excellent Deep Dimming in ADIM

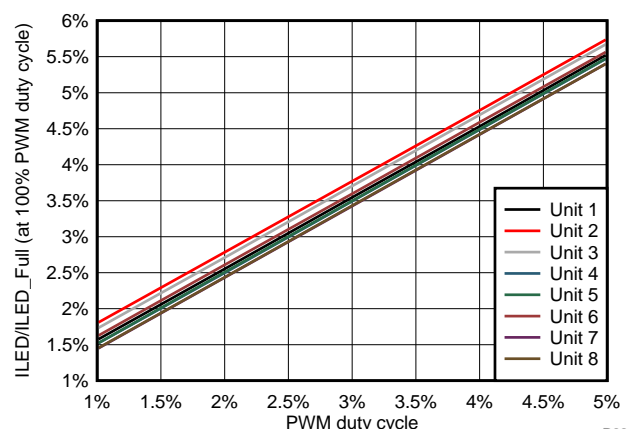

D001



Table of Contents

1 Features	1	8.3 Feature Description.....	13
2 Applications	1	8.4 Device Functional Modes.....	17
3 Description	1	9 Application and Implementation	20
4 Revision History	2	9.1 Application Information.....	20
5 Description (continued)	4	9.2 Typical Application	20
6 Pin Configuration and Functions	4	10 Power Supply Recommendations	30
7 Specifications	5	11 Layout	30
7.1 Absolute Maximum Ratings	5	11.1 Layout Guidelines	30
7.2 ESD Ratings.....	5	11.2 Layout Example	31
7.3 Recommended Operating Conditions.....	5	12 Device and Documentation Support	32
7.4 Thermal Information	5	12.1 Device Support.....	32
7.5 Electrical Characteristics.....	6	12.2 Documentation Support	32
7.6 Timing Requirements	7	12.3 Receiving Notification of Documentation Updates	32
7.7 Switching Characteristics	7	12.4 Community Resources.....	32
7.8 Typical Characteristics	8	12.5 Trademarks	32
8 Detailed Description	11	12.6 Electrostatic Discharge Caution.....	32
8.1 Overview	11	12.7 Glossary	32
8.2 Functional Block Diagram	12	13 Mechanical, Packaging, and Orderable Information	33

4 Revision History

Changes from Revision A (March 2017) to Revision B

Page

• Changed "Hiccup Mode" to "Auto-Retry Mode" in the <i>Features</i> section and throughout the data sheet	1
• Changed the package description	1
• Changed the <i>Applications</i> section	1
• Changed "WLED" to "mono-color or IR LED" in the first sentence of the <i>Description</i> section	1
• Changed package descriptor from SOT23 to SOT-23-THIN in the <i>Device Information</i> table.....	1
• Changed pinout diagram and associated text	4
• Changed "PWM duty input" to "PWM input duty cycle" in the <i>Pin Functions</i> table.....	4
• Changed "free-air" to "ambient" in the Absolute Maximum Ratings condition statement	5
• Changed "free-air" to "ambient" in the Recommended Operating Conditions condition statement	5
• Changed the package description in the <i>Thermal Information</i> table header.....	5
• Changed "Rising" and "Falling" to "Rising V_{PWM} " and "Falling V_{PWM} " for the V_{ADIM} , V_{PDIM} , and V_{PVM} <i>Electrical Characteristics</i> table entries	6
• Changed "SW" to " V_{SW} " in the Test Conditions column for the R_{HSD} entry in the <i>Electrical Characteristics</i> table.....	6
• Changed "dim mode" to "dimming mode" in the Test Conditions column for the I_{LIM_HS1} entry in the <i>Electrical Characteristics</i> table	6
• Changed the symbol for switching frequency from F_{SW} to f_{SW}	7
• Changed V_{IN} to V_{VIN} in the <i>Typical Characteristics</i> condition statement	8
• Changed "hiccup up mode" to "auto-retry mode"	11
• Changed "duty" to "duty cycle" in multiple locations throughout the data sheet	13
• Changed "PWM duty" to "PWM duty cycle" in the Figure 16 image	13
• Changed "floating driver" to "boot regulator" in the Bootstrap Voltage (BOOT) section	14
• Changed V_{IN} to V_{VIN} in multiple locations throughout the data sheet.....	14
• Changed various wording in the Added the Device Support and Documentation Support sections section for clarity, and changed "512 switching cycles" to " $t_{SHUTDOWN_DELAY}$ "	14
• Changed "hiccup up" to "auto-retry mode" in the Fault Protection section	15

Revision History (continued)

• Changed "hiccup" to "auto-retry" or "shutdown -and-restart," and deleted "programmed for XXX switching cycles" text..	15
• Changed "will be clamped by low" to "is clamped at the low-"	15
• Changed "hiccup" to "auto-retry" or "shutdown -and-restart," and deleted "programmed for XXX switching cycles" text..	15
• Changed "hiccup" to "auto-retry" or "shutdown -and-restart," and deleted "programmed for XXX switching cycles" text..	15
• Changed "hiccup" to "auto-retry" or "shutdown -and-restart," and deleted "programmed for XXX switching cycles" text..	15
• Changed "Recycle V_{IN} can reset" to "Cycling VIN resets"	16
• Changed "once the device shuts down, it starts" to "a device shutdown starts"	16
• Changed "hiccup" to "auto-retry" or "shutdown -and-restart," and deleted "programmed for XXX switching cycles" text..	16
• Changed "hiccup" to "auto-retry" or "shutdown -and-restart," and deleted "programmed for XXX switching cycles" text..	16
• Changed "Vin at" to " V_{VIN} "	17
• Changed "VADIM" to " V_{ADIM} " and "VPDIM" to " V_{PDIM} "	17
• Changed "it's" to "the output is"	17
• Changed " V_{IN} " to "VIN" and "recycled" to "cycled" at the end of the Mode Detection	17
• Changed "a little big" to "excessive" in the Analog Dimming Mode Operation section	18
• Changed "PWM duty cycle" to "PWM state"	19
• Changed " $12-V_{IN}$ " to " $12-V_{VIN}$ "	20
• Changed " F_{SW} " to " f_{SW} " and " $V_{IN(max)}$ " to " $V_{VIN(max)}$ " in Equation 3 from F to f	21
• Changed " F_{SW} " to " f_{SW} " and " $V_{IN(ripple)}$ " to " $V_{VIN(ripple)}$ " in Equation 8 from F to f	21
• Changed the symbol for frequency in Equation 11 from F to f	22
• Changed "RF" to " R_F " and "CF" to " C_F "	22
• Changed "VOUT" to " V_{OUT} " in the conditions of multiple application curves	24
• Changed the wording of the second and third paragraphs of the Inductor Selection section for clarity	27
• Changed the symbol for frequency in Equation 14 from F to f	27
• Changed "wide areas advantages" to "added width also"	30
• Changed "reduce the possibility" to "minimize"	30
• Added the Device Support and Documentation Support sections	32

Changes from Original (November 2016) to Revision A

Page

• Added initial release of the TPS54201 device	1
• Changed description to include protection modes	4
• Changed I_{LIM_HS1} and I_{LIM_HS2} CURRENT LIMIT	6
• Changed the low-side source-current limit from (2.4/3.4/4.4) to (2.3/3.3/4.4)	6
• Added TPS54201 $t_{HIC_THERMAL}$, t_{HIC_OV} and t_{HIC_WAIT} Timing Requirements	7
• Added TPS54201 LED Short Protection image	25
• Added TPS54201 LED Open Protection image	25
• Added TPS54201 Sense Resistor Short Protection image	25

5 Description (continued)

Cycle-by-cycle current limit in the high-side MOSFET protects the converter in an overload condition and is enhanced by a low-side MOSFET freewheeling current limit which prevents current runaway. There is a low-side MOSFET sinking current limit to prevent excessive reverse current. For safety and protection, the TPS54200 and TPS54201 devices include LED-open and -short protection, sense-resistor-open and -short protection, and device thermal protection. The TPS54200 device implements shutdown-and-latch mode protection, whereas the TPS54201 device adopts auto-retry mode protection.

6 Pin Configuration and Functions

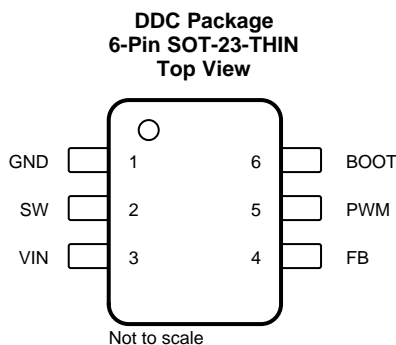

Pin Functions

PIN		TYPE ⁽¹⁾	DESCRIPTION
NAME	NO.		
BOOT	6	O	A bootstrap capacitor is required between BOOT and SW.
FB	4	I	LED current-detection feedback
GND	1	G	Power ground
PWM	5	I	Dimming input. Default low (internally pulled low). In analog dimming mode, the internal reference is proportional to the PWM input duty cycle. In PWM dimming mode, LED current is ON during the PWM high period in each PWM cycle.
SW	2	O	Switching node to the external inductor
VIN	3	P	Input supply voltage

(1) I = Input, O = Output, P = Supply, G = Ground

7 Specifications

7.1 Absolute Maximum Ratings

over operating ambient temperature range (unless otherwise noted)⁽¹⁾

		MIN	MAX	UNIT
Input voltage range, V_I	VIN	-0.3	30	V
	PWM	-0.3	7	
	FB	-0.3	7	
Output voltage range, V_O	BOOT-SW	-0.3	7	V
	SW	-0.3	30	
	SW (20 ns transient)	-5	30	
Operating junction temperature, T_J		-40	150	°C
Storage temperature range, T_{stg}		-65	150	°C

- (1) Stresses beyond those listed under *Absolute Maximum Ratings* may cause permanent damage to the device. These are stress ratings only, which do not imply functional operation of the device at these or any other conditions beyond those indicated under *Recommended Operating Conditions*. Exposure to absolute-maximum-rated conditions for extended periods may affect device reliability.

7.2 ESD Ratings

			VALUE	UNIT
$V_{(ESD)}$	Electrostatic discharge	Human-body model (HBM), per ANSI/ESDA/JEDEC JS-001 ⁽¹⁾	±4000	V
		Charged-device model (CDM), per JEDEC specification JESD22-C101 ⁽²⁾	±1500	

- (1) JEDEC document JEP155 states that 500-V HBM allows safe manufacturing with a standard ESD control process.
 (2) JEDEC document JEP157 states that 250-V CDM allows safe manufacturing with a standard ESD control process.

7.3 Recommended Operating Conditions

over operating ambient temperature range (unless otherwise noted)

		MIN	MAX	UNIT	
V_I	Input voltage range	VIN	4.5	28	V
		PWM	-0.1	6	
		FB	-0.1	6	
V_O	Output voltage range	BOOT-SW	-0.1	6.5	V
		SW	-0.1	28	
T_J	Operating junction temperature	-40	125	°C	

7.4 Thermal Information

THERMAL METRIC ⁽¹⁾		TPS5420x	UNIT
		DDC (SOT-23-THIN)	
		6 PINS	
$R_{\theta JA}$	Junction-to-ambient thermal resistance	89.2	°C/W
$R_{\theta JC(top)}$	Junction-to-case (top) thermal resistance	39.5	°C/W
$R_{\theta JB}$	Junction-to-board thermal resistance	14.7	°C/W
Ψ_{JT}	Junction-to-top characterization parameter	1.2	°C/W
Ψ_{JB}	Junction-to-board characterization parameter	14.7	°C/W

- (1) For more information about traditional and new thermal metrics, see the *Semiconductor and IC Package Thermal Metrics* application report, [SPRA953](#).

7.5 Electrical Characteristics

The electrical ratings specified in this section apply to all specifications in this document, unless otherwise noted. These specifications are interpreted as conditions that do not degrade the device parametric or functional specifications for the life of the product containing it. $T_J = -40^{\circ}\text{C}$ to 125°C , $V_{VIN} = 4.5\text{ V}$ to 28 V , (unless otherwise noted).

PARAMETER		TEST CONDITIONS	MIN	TYP	MAX	UNIT
INPUT SUPPLY						
V_{VIN}	Input voltage range		4.5		28	V
I_{OFF}	Shutdown current	PWM = GND		2	8.6	μA
V_{VIN_UVLO}	VIN undervoltage lockout	Rising V_{VIN}	3.83	4.2	4.47	V
		Falling V_{VIN}	3.4	3.7	3.95	
	Hysteresis			470		mV
DIMMING (PWM PIN)						
V_{ADIM}	Analog dimming-mode threshold	Rising V_{PWM}	1.97	2.07	2.17	V
		Falling V_{PWM}		1.8		
V_{PDIM}	PWM dimming-mode threshold	Rising V_{PWM}	0.9	1	1.1	V
		Falling V_{PWM}		0.8		
V_{PWM}	Threshold to identify PWM duty cycle	Rising V_{PWM}	0.91	1	1.12	V
		Falling V_{PWM}	0.5	0.63	0.72	
$V_{PWM_SHUTDOWN}$	Shutdown threshold		0.35	0.55		V
FEEDBACK AND ERROR AMPLIFIER						
V_{FB1}	Feedback voltage in analog dimming mode	PWM = 3.3 V, SW duty cycle > 90%	201	205	210	mV
V_{FB2}	Feedback voltage in PWM dimming mode	PWM = 1.5 V, SW duty cycle > 90%	96	100	104	mV
BOOT PIN						
V_{BOOT_UVLO}	BOOT-SW UVLO threshold	Rising		2.1	2.33	V
		Falling		2	2.2	
POWER STAGE						
R_{HSD}	High-side FET on-resistance	$V_{BOOT} - V_{SW} = 6\text{ V}$		150	259	m Ω
R_{LSD}	Low-side FET on-resistance	$V_{VIN} > 6\text{ V}$		70	120	m Ω
CURRENT LIMIT						
I_{LIM_HS1}	High-side current limit 1	Either one of the following conditions: 1. PWM dimming mode 2. Analog dimming mode and PWM duty cycle >25%	2.4	3	3.6	A
I_{LIM_HS2}	High-side current limit 2	Analog dimming mode and PWM duty cycle <25%	1	1.4	1.8	A
$I_{LIM_LS_SOURCE}$	Low-side source current limit	$V_{VIN} > 6\text{ V}$	2.3	3.3	4.4	A
$I_{LIM_LS_SINK}$	Low-side sink current limit	$V_{VIN} > 6\text{ V}$	1.25	1.7	2.2	A
FAULT PROTECTION						
Thermal shutdown ⁽¹⁾	Rising temperature		150	160	170	$^{\circ}\text{C}$
	Hysteresis			10		$^{\circ}\text{C}$
V_{OVP}	Overvoltage protection			1		V
V_{OCP}	Overcurrent protection			120%		

(1) Not production tested

7.6 Timing Requirements

		MIN	TYP	MAX	UNIT
THERMAL SHUTDOWN					
$t_{\text{HIC_THERMAL}}$	TPS54200 and TPS54201 thermal shutdown auto-retry time		32 768		Cycles
OVERVOLTAGE PROTECTION					
$t_{\text{HIC_OV}}$	TPS54201 auto-retry time for overvoltage protection		32 768		Cycles
OVERCURRENT AND OPEN-LOOP PROTECTION					
$t_{\text{SHUTDOWN_DELAY}}$	TPS54200 shutdown delay time for open-loop and overcurrent protection		512		Cycles
$t_{\text{HIC_WAIT}}$	TPS54201 auto-retry wait time for open-loop and overcurrent protection		512		Cycles
$t_{\text{HIC_OC}}$	TPS54201 auto-retry time for open-loop and overcurrent protection		16 384		Cycles
SOFT START					
t_{SS}	Internal soft-start time		0.6		ms

7.7 Switching Characteristics

$T_J = -40^\circ\text{C}$ to 125°C , $V_{\text{VIN}} = 4.5\text{ V}$ to 28 V , (unless otherwise noted).

PARAMETER		TEST CONDITIONS	MIN	TYP	MAX	UNIT
OSCILLATOR						
f_{sw}	Switching frequency		480	600	700	kHz
ON-TIME CONTROL						
$t_{\text{MIN_ON}}$	Minimum on-time	Measured at 90% to 90% and 1-A loading		90	105	ns

7.8 Typical Characteristics

$V_{IN} = 12\text{ V}$, unless otherwise specified

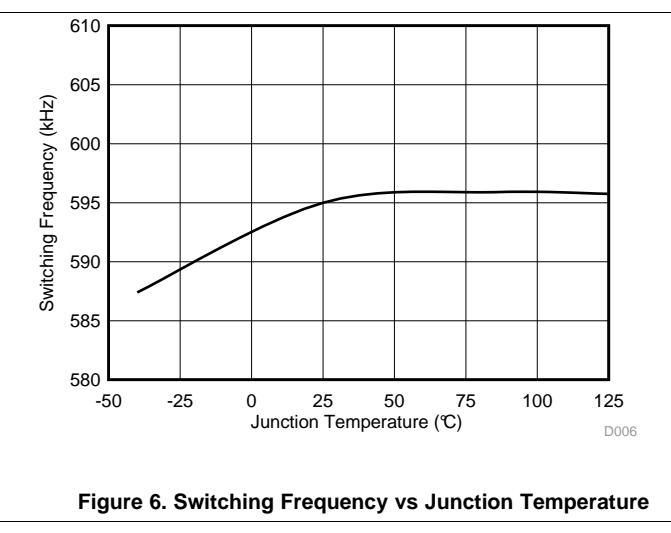
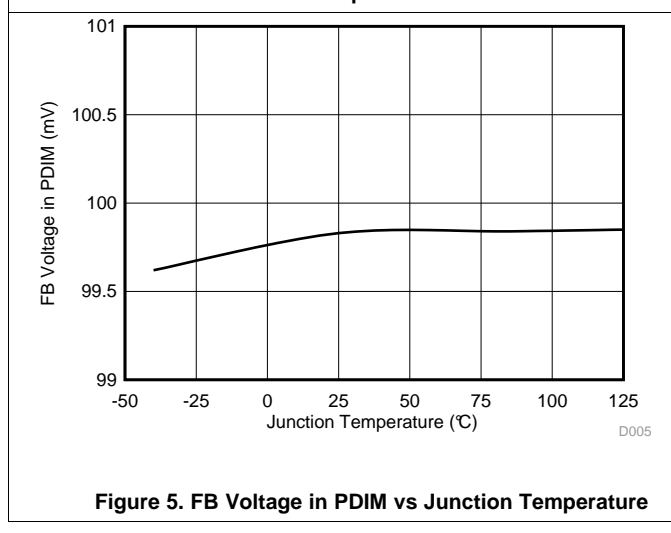
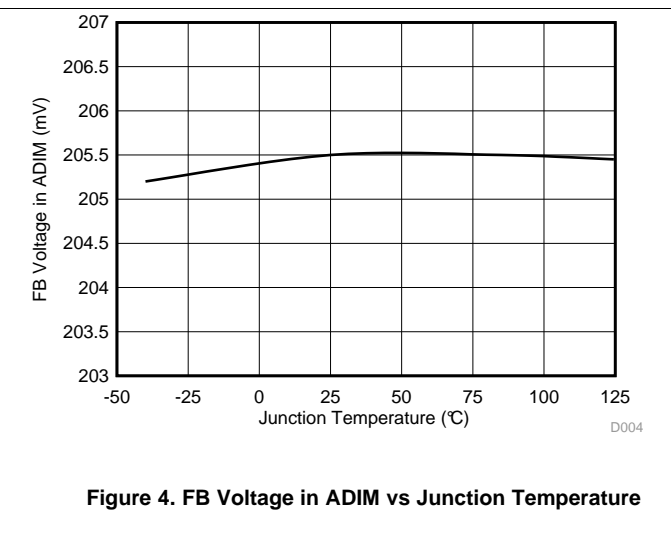
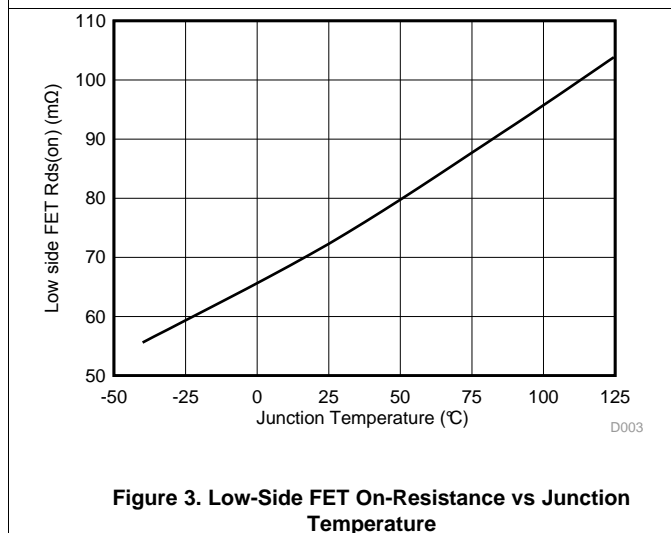
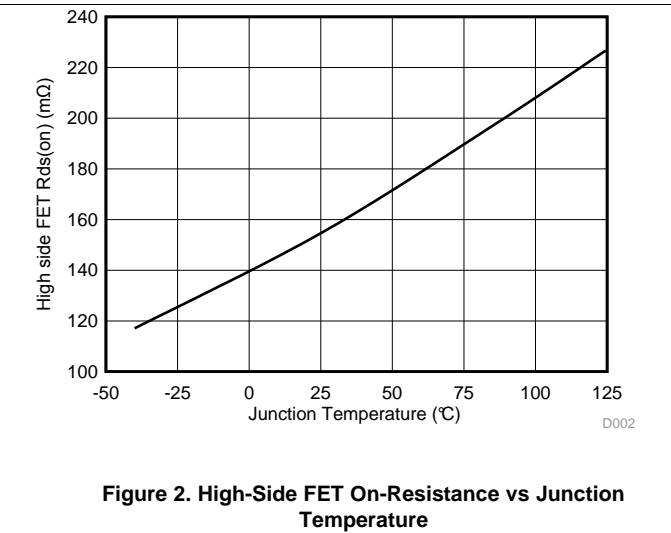
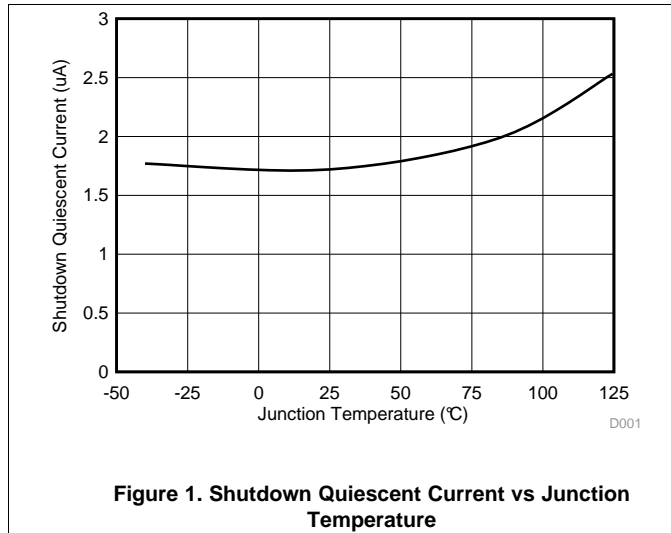

Typical Characteristics (continued)

$V_{VIN} = 12\text{ V}$, unless otherwise specified

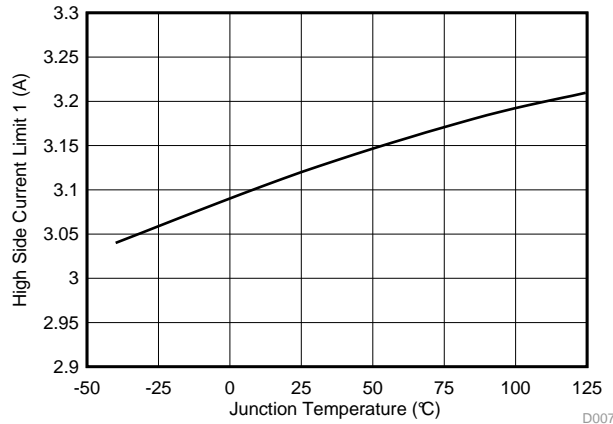

Figure 7. High-Side Source Current Limit 1 Threshold vs Junction Temperature

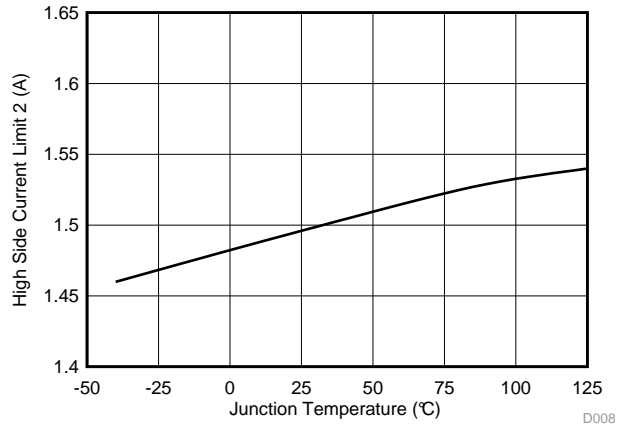

Figure 8. High-Side Source Current Limit 2 Threshold vs Junction Temperature

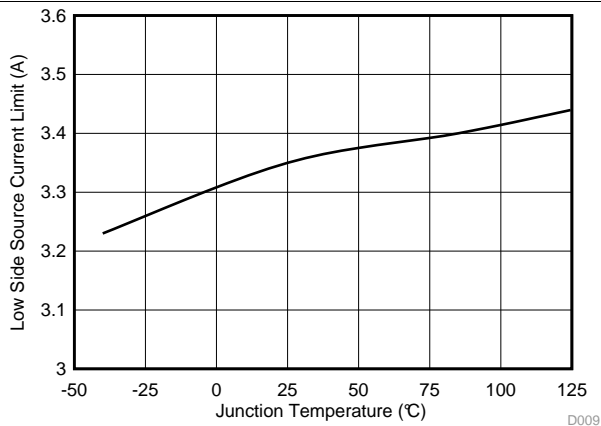

Figure 9. Low-Side Source Current Limit Threshold vs Junction Temperature

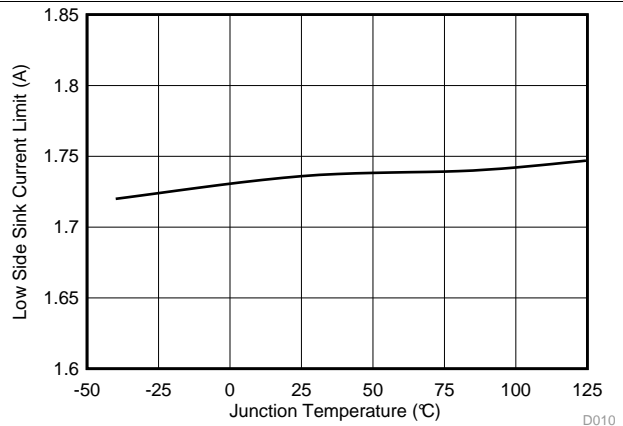

Figure 10. Low-Side Sink Current Limit Threshold vs Junction Temperature

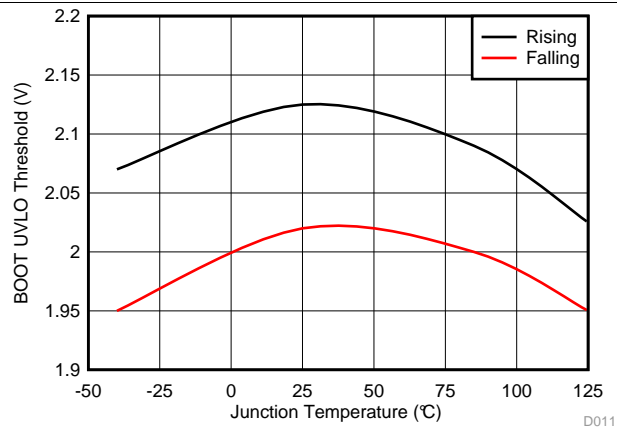

Figure 11. BOOT-SW UVLO Threshold vs Junction Temperature

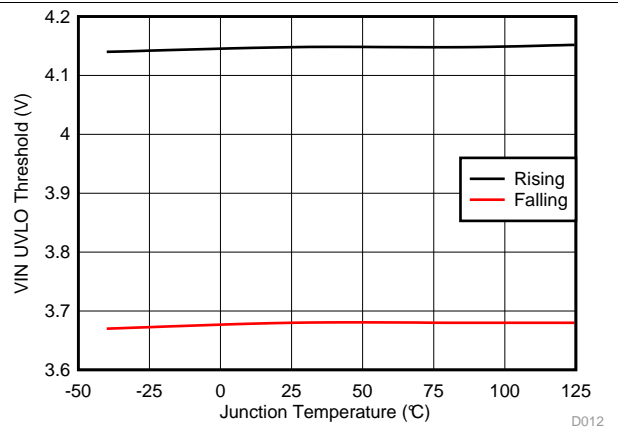

Figure 12. VIN UVLO Threshold vs Junction Temperature

Typical Characteristics (continued)

$V_{VIN} = 12\text{ V}$, unless otherwise specified

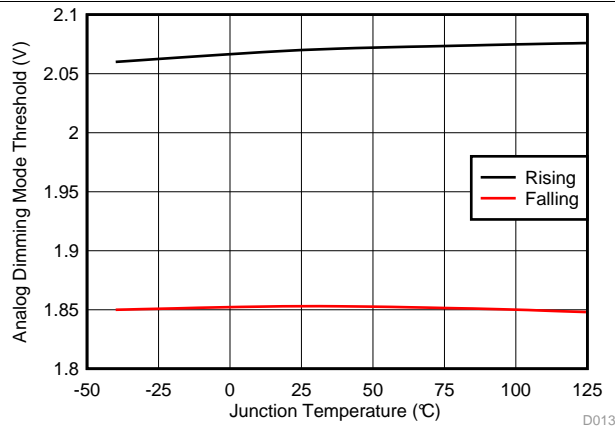

Figure 13. Analog Dimming Mode Threshold vs Junction Temperature

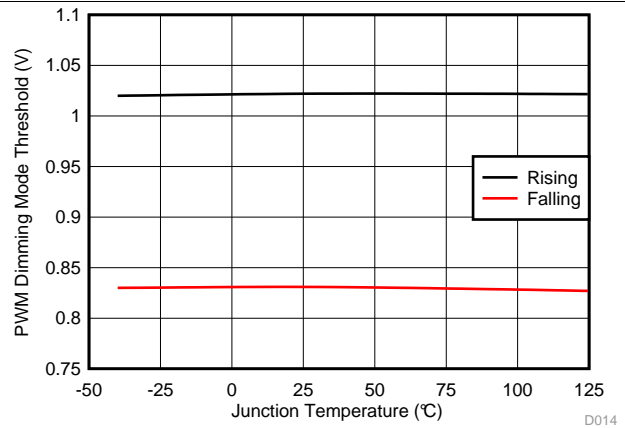

Figure 14. PWM Dimming Mode Threshold vs Junction Temperature

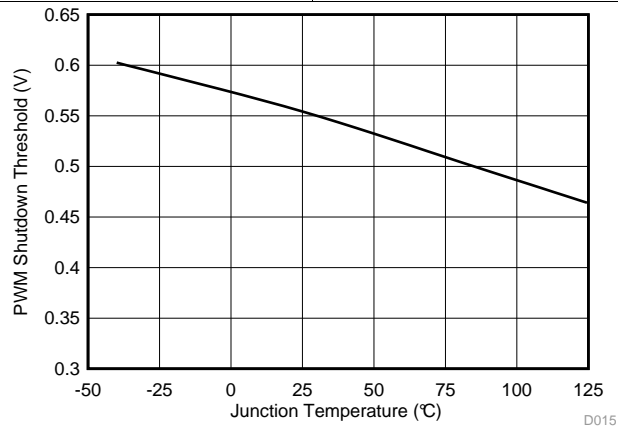

Figure 15. PWM Shutdown Threshold vs Junction Temperature

8 Detailed Description

8.1 Overview

The TPS5420x device is a 1.5-A synchronous buck LED driver up to 28-V input. Current-mode operation provides fast transient response. The optimized internal compensation network minimizes the external component count and simplifies the control loop design.

The TPS5420x device has a fixed 600-kHz switching frequency for a good tradeoff between efficiency and size.

The integrated 150-m Ω high-side MOSFET and 70-m Ω low-side MOSFET allow for a high-efficiency LED driver with continuous output current up to 1.5 A.

The TPS5420x device supports deep dimming in both analog and PWM dimming modes. In analog dimming mode, the internal reference voltage is changed in proportion to the duty cycle of the PWM signal in the 1% to 100% range. In the PWM dimming mode, the LED turns on and off periodically according to the PWM duty cycle. For higher efficiency, the internal reference is halved to 100 mV.

Cycle-by-cycle current limit in the high-side MOSFET protects the converter in overload conditions and is enhanced by a low-side MOSFET freewheeling current limit which prevents current runaway. There is a low-side MOSFET sinking-current limit to prevent excessive reverse current.

For safety and protection, the TPS5420x includes LED-open and -short protection, sense-resistor-open and -short protection, and device thermal protection. The TPS54200 device implements shutdown-and-latch mode protection, whereas the TPS54201 device implements auto-retry mode protection.

8.2 Functional Block Diagram

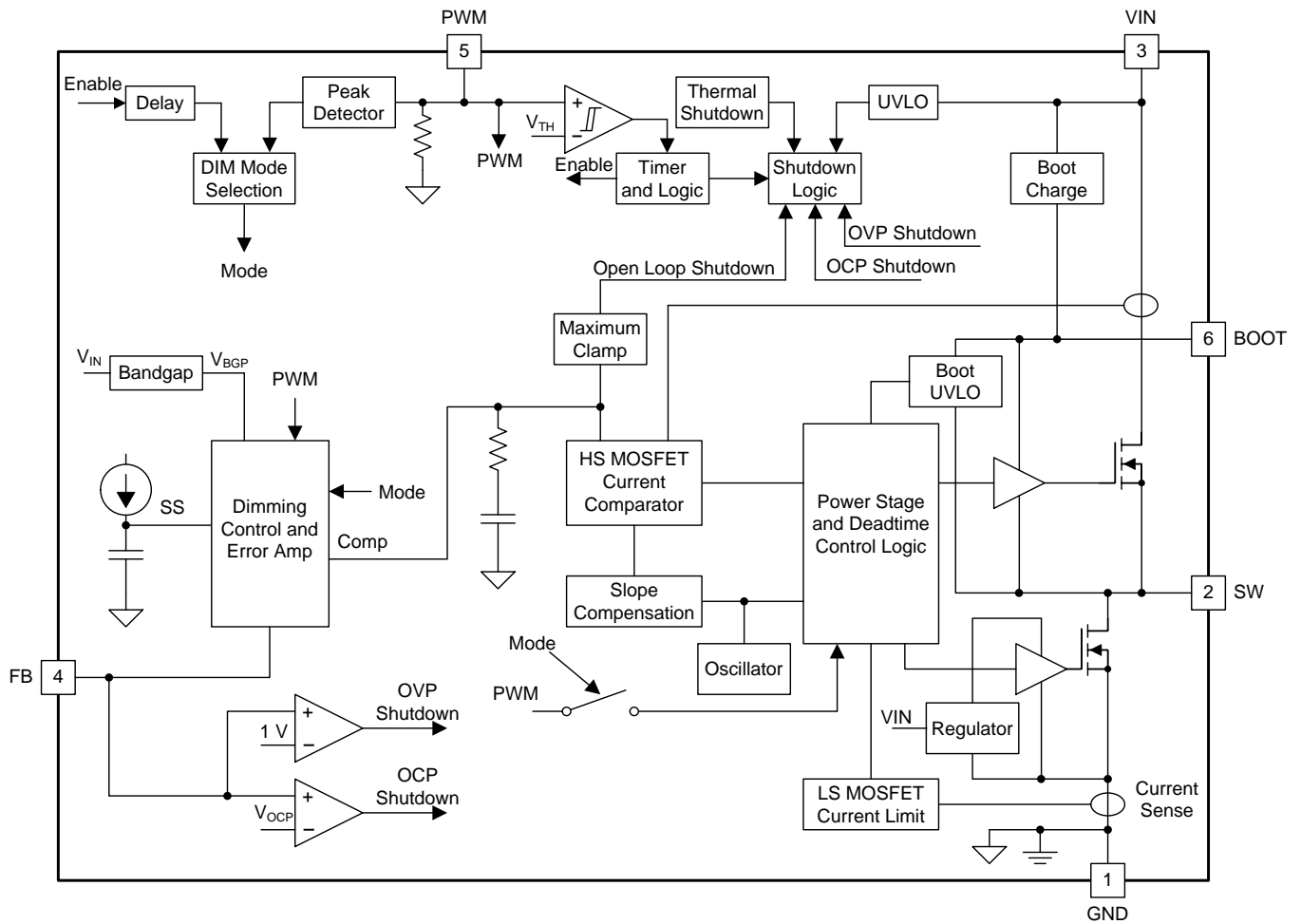

Copyright © 2016, Texas Instruments Incorporated

8.3 Feature Description

8.3.1 Fixed-Frequency PWM Control

The device uses a fixed-frequency and peak-current-mode control. The LED current is sensed by a resistor in series with the LED string. The sensed voltage is fed to the FB pin through an RC filter, and then compared to an internal voltage reference by an error amplifier. An internal oscillator initiates the turnon of the high-side power switch. The error amplifier output is compared to the current of the high-side power switch. When the power-switch current reaches the error-amplifier output-voltage level, the high-side power switch is turned off and the low-side power switch is turned on. Thus, the error amplifier output voltage regulates inductor peak current, and in turn the LED current, to a target value. The device implements a current limit by clamping the error amplifier voltage to a maximum level and also implements a minimum clamp for improved transient-response performance.

8.3.2 Error Amplifier

The device has a transconductance amplifier as the error amplifier. The error amplifier compares the FB voltage to the lower of the internal soft-start voltage or the internal voltage reference. The transconductance of the error amplifier is 240 $\mu\text{A/V}$ typically. The frequency compensation components are placed internally between the output of the error amplifier and ground.

8.3.3 Slope Compensation and Output Current

The device adds a compensating ramp to the signal of the switch current. This slope compensation prevents subharmonic oscillations as the duty cycle increases. The available peak inductor current remains constant over the full duty-cycle range.

8.3.4 Input Undervoltage Lockout

The device implements internal undervoltage-lockout (UVLO) circuitry on the VIN pin. The device is disabled when the VIN pin voltage falls below the internal VIN UVLO threshold, which is 3.7 V typical. The internal VIN UVLO threshold has a hysteresis of 470 mV.

8.3.5 Voltage Reference

The voltage reference system produces a precise $\pm 2.5\%$ voltage reference over temperature by scaling the output of a temperature-stable band-gap circuit when the PWM duty cycle is 100%. In PWM dimming mode, the voltage reference, V_{REF} , is fixed at 100 mV. In analog dimming mode, V_{REF} , is proportional to the duty cycle of PWM as shown in Figure 16.

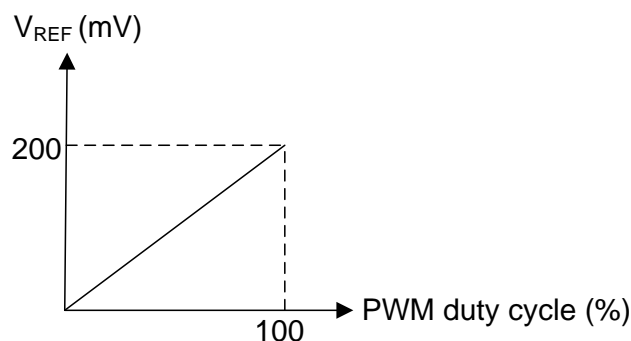

Figure 16. V_{REF} vs PWM Duty Cycle in Analog Dimming Mode

Feature Description (continued)

8.3.6 Setting LED Current

Once the voltage reference, V_{REF} , is chosen, one can set the LED current by choosing the proper sensing resistor according to [Equation 1](#):

$$R_{SENSE} = \frac{V_{REF}}{I_{LED}} \quad (1)$$

8.3.7 Internal Soft Start

The TPS5420x device uses an internal soft-start function. The internal soft-start time is set to 0.6 ms typically.

8.3.8 Bootstrap Voltage (BOOT)

The TPS5420x has an integrated boot regulator and requires a 0.1- μ F ceramic capacitor between the BOOT and SW pins to provide the gate drive voltage for the high-side MOSFET. A ceramic capacitor with an X7R or X5R grade dielectric is recommended because of the stable characteristics over temperature and voltage. This boot regulator has its own UVLO protection. This UVLO rising threshold is 2.1 V with a hysteresis of 100 mV. A 6-V bootstrap voltage is maintained between BOOT and SW when $V_{VIN} > 6$ V.

8.3.9 Overcurrent Protection

The device is protected from overcurrent conditions by cycle-by-cycle current limiting on both the high-side MOSFET and the low-side MOSFET.

8.3.9.1 High-Side MOSFET Overcurrent Protection

The device implements current-mode control, which uses the internal COMP voltage to control the turnoff of the high-side MOSFET and the turnon of the low-side MOSFET on a cycle-by-cycle basis. During each cycle, the switch current and the current reference generated by the internal COMP voltage are compared. When the peak switch current intersects the current reference, the high-side switch turns off. During overcurrent conditions, such as when the sensing resistor is shorted, or an open circuit occurs in the feedback-filter RC network that drives FB low, the error amplifier responds by driving the COMP pin high, increasing the switch current. The error amplifier output is clamped internally. This clamp functions as a switch-current limit. This current limit is fixed at 3.1 A typical in PWM dimming mode. In analog dimming mode with the PWM duty cycle >25%, this limit is also 3.1 A. If the PWM duty cycle is below 25%, this limit is halved to 1.5 A typical. Furthermore, if an output overcurrent condition occurs for more than the shutdown delay time, $t_{SHUTDOWN_DELAY}$, the device shuts down and latches off to protect the LED from overcurrent damage.

8.3.9.2 Low-Side MOSFET Overcurrent Protection

While the low-side MOSFET is turned on, the conduction current is monitored by the internal circuitry. During normal operation, the low-side MOSFET sources current to the load. At the end of every clock cycle, the low-side MOSFET sourcing current is compared to the internally set low-side sourcing current-limit. If the low-side sourcing-current limit is exceeded, the high-side MOSFET does not turn on and the low-side MOSFET stays on for the next cycle. The high-side MOSFET turns on again when the low-side current is below the low-side sourcing current-limit at the start of a cycle.

8.3.9.3 Low-Side MOSFET Reverse Overcurrent Protection

The TPS5420x device implements low-side reverse-current protection by detecting the voltage across the low-side MOSFET. When the converter sinks current through its low-side FET, the control circuit turns off the low-side MOSFET if the reverse current is more than 1.7 A typical. By implementing this additional protection scheme, the converter is able to protect itself from excessive sink current during fault conditions.

Feature Description (continued)

8.3.10 Fault Protection

The device is protected from several kinds of fault conditions, such as LED open and short, sense-resistor open and short, and thermal shutdown. The only difference between the TPS54200 and TPS54201 devices is the different protection mode used. The TPS54200 device implements shutdown-and-latch mode protection, whereas the TPS54201 device implements auto-retry mode protection.

8.3.10.1 LED-Open Protection

When the LED load is open, the FB voltage is low, and the internal COMP voltage is driven high and clamped. This action triggers a shutdown delay counter (TPS54200) or auto-retry wait counter (TPS54201). For the TPS54200 device, once the shutdown delay time $t_{\text{SHUTDOWN_DELAY}}$ expires, the device shuts down and latches off. Both FETs are kept off. This is a latched shutdown. The device can be reset by recycling VIN. For TPS54201, once the auto-retry wait time $t_{\text{HIC_WAIT}}$ expires, the device shuts down and starts auto-retry timer $t_{\text{HIC_OC}}$. During the shutdown period, both FETs are kept off. Once the auto-retry timer expires, the TPS54201 device restarts again. If the failure still exists, the TPS54201 device repeats the foregoing shutdown-and-restart process.

8.3.10.2 LED Short Protection

When the LED load is shorted, the FB voltage is higher than V_{REF} , and the internal COMP voltage is driven low and clamped, and the high-side MOSFET is commanded on for a minimum on-time each cycle. In this condition, if the output voltage is too low, the inductor current may not be able to balance in a cycle, causing current runaway. Finally, the inductor current is clamped at the low-side MOSFET sourcing-current limit, which is much higher than target LED current. If the FB voltage is higher than the OCP threshold, which is 250 mV typical in analog dimming mode, or 120 mV typical in PWM dimming mode, the shutdown delay counter (TPS54200) or auto-retry wait counter (TPS54201) is triggered. For the TPS54200 device, once the shutdown delay time $t_{\text{SHUTDOWN_DELAY}}$ expires, the device shuts down and latches off. Both FETs are kept off. This is a latched shutdown. The device can be reset by recycling VIN. For the TPS54201 device, once the auto-retry wait time $t_{\text{HIC_WAIT}}$ expires, the device shuts down and starts auto-retry timer $t_{\text{HIC_OC}}$. During the shutdown period, both FETs are kept off. Once the auto-retry timer expires, the TPS54201 device restarts again. If the failure still exists, the TPS54201 device repeats the foregoing shutdown-and-restart process.

8.3.10.3 Sense-Resistor Short Protection

When the sense resistor is shorted, the FB voltage is low, and the internal COMP voltage is driven high and clamped. This action triggers the shutdown delay counter (TPS54200) or auto-retry wait counter (TPS54201). For the TPS54200 device, once the shutdown delay time $t_{\text{SHUTDOWN_DELAY}}$ expires, the device shuts down and latches off. Both FETs are kept off. This is a latched shut-down. The device can be reset by recycling VIN. For the TPS54201 device, once the auto-retry wait time $t_{\text{HIC_WAIT}}$ expires, the device shuts down and starts auto-retry timer $t_{\text{HIC_OC}}$. During the shutdown period, both FETs are kept off. Once the auto-retry timer expires, the TPS54201 device restarts again. If the failure still exists, the TPS54201 device repeats the foregoing shutdown-and-restart process.

8.3.10.4 Sense-Resistor Open Protection

When the sense resistor is open before the device powers on, the device charges the BOOT capacitor at the power-on moment. The charging current flows through the inductor, the output capacitor, and the RC filter at the FB pin to charge up the FB pin voltage. Once the device detects an FB voltage higher than the 1-V OVP threshold, the device shuts down immediately. For the TPS54200 device, this is a latched shutdown, and the device can be reset by cycling VIN. For the TPS54201 device, once the device shuts down, it starts the overvoltage auto-retry timer $t_{\text{HIC_OV}}$. During the shutdown period, both FETs are kept off. Once the overvoltage auto-retry timer expires, the TPS54201 device restarts again. If the failure still exists, the TPS54201 device repeats the foregoing auto-retry shutdown-and-restart process.

Feature Description (continued)

8.3.10.5 Overvoltage Protection

When the FB pin, for some reason, has a voltage higher than 1 V applied, the device shuts down immediately. Both FETs are kept off. This is called overvoltage protection. For the TPS54200 device, this is a latched shutdown. Cycling VIN resets the device. For the TPS54201 device, a device shutdown starts the overvoltage auto-retry timer $t_{\text{HIC_OV}}$. During the shutdown period, both FETs are kept off. Once the overvoltage auto-retry timer expires, the TPS54201 device restarts again. If the failure still exists, the TPS54201 device repeats the foregoing auto-retry shutdown-and-restart process.

8.3.10.6 Thermal Shutdown

The internal thermal-shutdown circuitry forces the device to stop switching if the junction temperature exceeds a typical value of 160°C. When the junction temperature drops below a typical value of 150°C, the internal thermal-auto-retry timer $t_{\text{HIC_THERMAL}}$ begins to count. The device reinitiates the power-up sequence once the thermal-auto-retry timer expires.

8.4 Device Functional Modes

8.4.1 Enable and Disable Device

The PWM pin performs not only the dimming function, but also the enable-and-disable function. When the VIN voltage is above the UVLO threshold, the TPS5420x device can be enabled by driving the PWM pin higher than the threshold voltage, 0.56 V typical. To disable the device, keep the PWM pin lower than the threshold voltage, 0.55 V typical, for 40 ms or longer. The PWM pin has an internal pulldown resistor, so floating this pin disables the device.

The suggested power-on sequence is applying V_{VIN} first, followed by the PWM signal.

8.4.2 Mode Detection

The magnitude of the PWM signal is used to determine which dimming mode the device enters. The internal peak detector at the PWM pin holds the magnitude of the PWM signal. Once the device is enabled, after 300- μ s delay, the output of the peak detector is compared with two voltage thresholds, V_{ADIM} and V_{PDIM} , which are 1 V and 2.07 V, respectively. If the output of the peak detector is higher than 2.07 V, analog dimming mode is chosen and locked. If the output is less than 1 V, the device waits another 300 μ s and compares again, and this process repeats until at least one mode is chosen and locked. See Figure 17 and Table 1 for reference. After the mode is detected and locked, soft start begins, the output voltage ramps up, and the LED current is regulated at the target value. The dimming mode cannot be changed unless VIN or PWM is cycled.

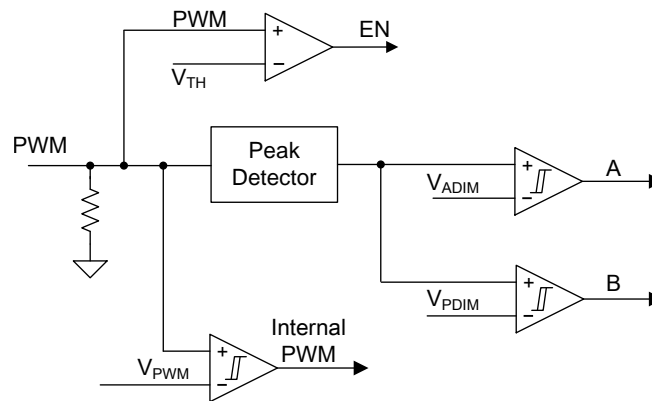

Figure 17. Mode Detection Circuit

Table 1. Mode Detection Condition

A	B	MODE
H	H	Enter analog dimming mode
L	H	Enter PWM dimming mode
L	L	Keep detecting until one dimming mode is locked

8.4.3 Analog Dimming Mode Operation

Once the analog dimming mode is chosen, the internal voltage reference for the FB pin is approximately 200 mV at full scale, and proportional to the PWM duty cycle as shown in Figure 16. LED current is continuous in this mode, and the current magnitude can be adjusted by changing PWM duty cycle, see Figure 18. Because the internal voltage reference is filtered from the PWM signal, a too-low PWM frequency may cause excessive ripple at the voltage reference. To minimize this ripple, the suggested PWM signal frequency is 10 kHz or higher, such as 50 kHz.

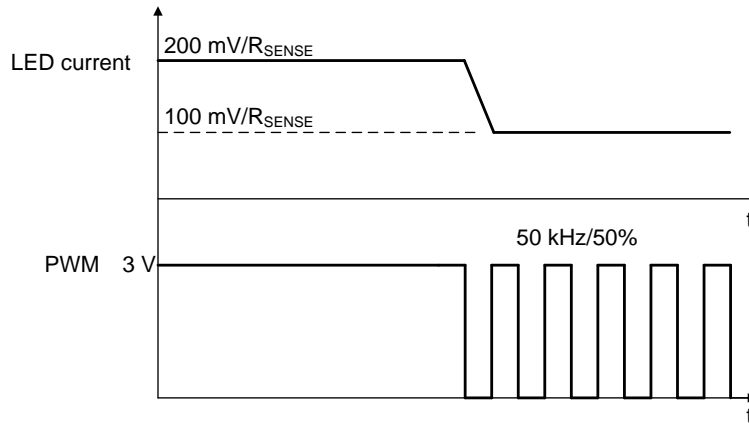

Figure 18. Analog Dimming Operation

A comparator with 400-mV hysteresis is used to generate the internal PWM signal, see Figure 17. This internal PWM duty cycle determines the voltage reference. To make sure the PWM pin signal is correctly identified, the high level of the PWM signal should be higher than 1 V, and the low level should be lower than 0.6 V. Figure 19 shows the relationship between the external PWM and internal PWM signals.

8.4.4 PWM Dimming-Mode Operation

Once the PWM dimming mode is chosen, the internal voltage reference for the FB pin is fixed at 100 mV. The LED current is on or off corresponding to the PWM state, see Figure 19. Due to the limited control-loop response, to get a relatively linear dimming performance, the suggested PWM signal frequency should be less than 1 kHz.

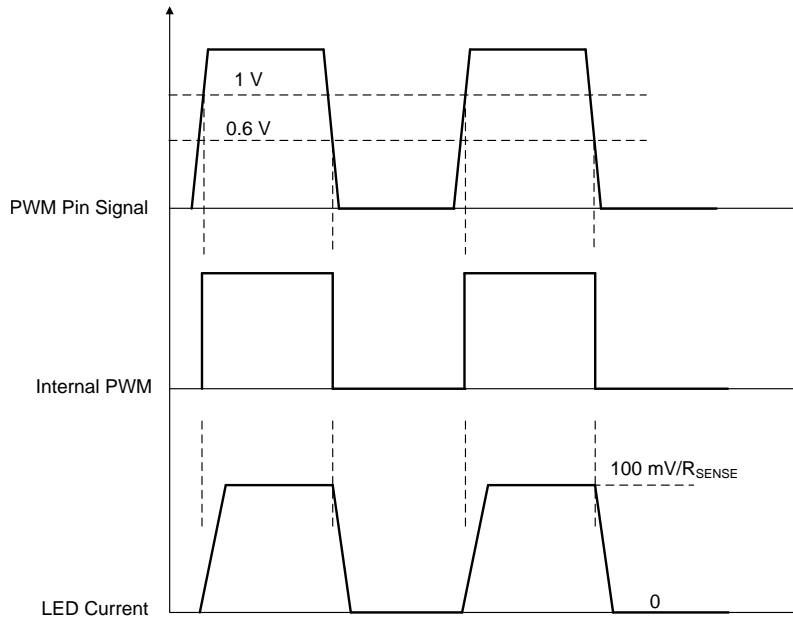

Figure 19. PWM Dimming Operation

In some application where dimming is not needed, one can just connect a resistor divider from V_{VIN} to the PWM pin as Figure 20 shows.

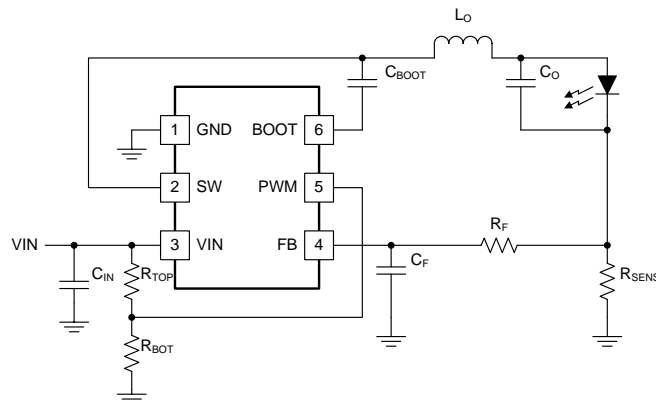

Figure 20. Application Without Dimming

R_{TOP} and R_{BOT} should be sized to make sure the PWM pin voltage is higher than 1 V when V_{VIN} reaches its steady voltage. It is best to make sure the PWM pin voltage is less than 2 V, thus one can have 100 mV at the FB pin for better efficiency. Use 10 k Ω as a good starting point for R_{BOT} , then choose R_{TOP} according to Equation 2:

$$R_{TOP} = \left(\frac{V_{IN}}{V_{PWM}} - 1 \right) \times R_{BOT} \quad (2)$$

9 Application and Implementation

NOTE

Information in the following applications sections is not part of the TI component specification, and TI does not warrant its accuracy or completeness. TI's customers are responsible for determining suitability of components for their purposes. Customers should validate and test their design implementation to confirm system functionality.

9.1 Application Information

The TPS5420x device is typically used as a buck converter to drive one or more LEDs from a 4.5-V to 28-V input. The TPS5420x device supports both analog dimming mode and PWM dimming mode.

9.2 Typical Application

9.2.1 TPS5420x 12-V Input, 1.5-A, 3-Piece IR LED Driver With Analog Dimming

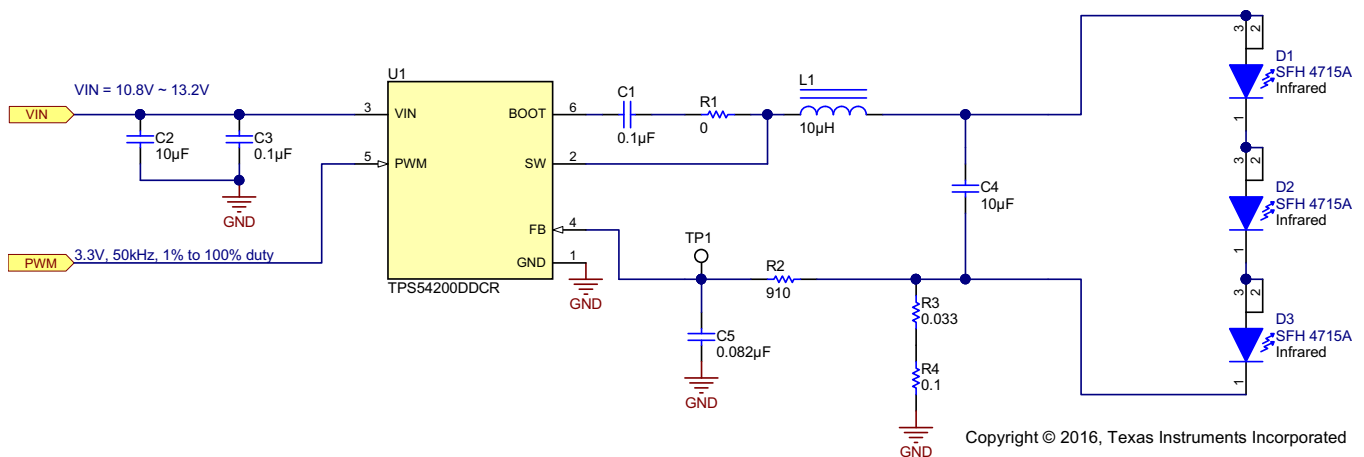

Figure 21. 12-V V_{IN} , 1.5-A, 3-Piece IR LED, Analog Dimming Reference Design

9.2.1.1 Design Requirements

For this design example, use the parameters in [Table 2](#).

Table 2. Design Parameters

PARAMETER	VALUE
Input voltage range	10.8 V to 13.2 V
LED string forward voltage	5.4-V stack
Output voltage	5.6 V
LED current at 100% PWM duty cycle	1.5 A
LED current ripple	30 mA or less
Input voltage ripple	400 mV or less
PWM dimming range	1% to 100%, 3.3 V, 50 kHz

9.2.1.2 Detailed Design Procedure

9.2.1.2.1 Inductor Selection

Use [Equation 3](#) to calculate the minimum value of the output inductor (L_{MIN}).

$$L_{MIN} = \frac{V_{OUT} \times (V_{VIN(max)} - V_{OUT})}{V_{VIN(max)} \times K_{IND} \times I_{LED} \times f_{SW}}$$

where

- K_{IND} is a coefficient that represents the amount of inductor ripple current relative to the maximum LED current.
- I_{LED} is the maximum LED current.
- V_{OUT} is the sum of the voltage across LED load and the voltage across the sense resistor. (3)

In general, the suggested value of K_{IND} is between 0.2 and 0.4. For an application that can tolerate higher LED current ripple or use larger output capacitors, one can choose 0.4 for K_{IND} . Otherwise, a smaller K_{IND} like 0.2 can be chosen to get low-enough LED current ripple.

With the chosen inductor value the user can calculate the actual inductor current ripple using [Equation 4](#).

$$I_{L(ripple)} = \frac{V_{OUT} \times (V_{VIN(max)} - V_{OUT})}{V_{VIN(max)} \times L \times f_{SW}} \quad (4)$$

The inductor rms-current and saturation-current ratings must be greater than the rms current and saturation current seen in the application. This ensures that the inductor does not overheat or saturate. During power up, transient conditions, or fault conditions, the inductor current can exceed its normal operating current. For this reason, the most conservative approach is to specify an inductor with a saturation current rating equal to or greater than the converter current limit. This is not always possible due to application size limitations. The peak-inductor-current and rms-current equations are shown in [Equation 5](#) and [Equation 6](#).

$$I_{L(peak)} = I_{LED} + \frac{I_{L(ripple)}}{2} \quad (5)$$

$$I_{L(rms)} = \sqrt{I_{LED}^2 + \frac{I_{L(ripple)}^2}{12}} \quad (6)$$

In this design, choose $K_{IND} = 0.3$. According to the LED manufacturer's data sheet, the IR LED has 1.75-V forward voltage at 1.5-A current, so $V_{OUT} = 1.75 \text{ V} \times 3 + 0.2 \text{ V} = 5.45 \text{ V}$ and the calculated inductance is 11.9 μH . A 10- μH inductor (part number is 744066100 from Würth) is chosen. With this inductor, the ripple, peak, and rms currents of the inductor are 0.53 A, 1.77 A, and 1.51 A, respectively. The chosen inductor has ample margin.

9.2.1.2.2 Input Capacitor Selection

The device requires an input capacitor to reduce the surge current drawn from the input supply and the switching noise from the device. Ceramic capacitors with X5R or X7R dielectrics are highly recommended because of their low ESR and small temperature coefficients. For most applications, a 10- μF capacitor is enough. An additional 0.1- μF capacitor from VIN to GND is optional to provide additional high-frequency filtering. The input capacitor must have a voltage rating greater than the maximum input voltage and have a ripple-current rating greater than the maximum input-current ripple of the converter. The rms input-ripple current is calculated in [Equation 7](#), where D is the duty cycle (output voltage divided by input voltage).

$$I_{CIN(rms)} = I_{LED} \times \sqrt{D \times (1-D)} \quad (7)$$

Use [Equation 8](#) to calculate the input ripple voltage, where ESR_{CIN} is the ESR of input capacitor. Ceramic capacitance tends to decrease as the applied dc voltage increases. This depreciation must be accounted for when calculating input ripple voltage.

$$V_{VIN(ripple)} = \frac{I_{LED} \times D \times (1-D)}{C_{IN} \times f_{SW}} + I_{LED} \times ESR_{CIN} \quad (8)$$

In this design, a 10- μF , 35-V X7R ceramic capacitor, part number GRM32ER7YA106KA12L from muRata, is chosen. This yields around 70-mV input ripple voltage. The calculated rms input ripple current is 0.75 A, well below the ripple-current rating of the capacitor.

9.2.1.2.3 Output Capacitor Selection

The output capacitor reduces the high-frequency ripple current through the LED string. Various guidelines disclose how much high-frequency ripple current is acceptable in the LED string. Excessive ripple current in the LED string increases the rms current in the LED string, and therefore the LED temperature increases.

1. Look up the total dynamic resistance of the LED string (R_{LED}) using the LED manufacturer's data sheet.
2. Calculate the required impedance of the output capacitor (Z_{OUT}), given the acceptable peak-to-peak ripple current through the LED string, $I_{LED(ripple)}$. $I_{L(ripple)}$ is the peak-to-peak inductor ripple current as calculated previously in the [Inductor Selection](#) section.
3. Calculate the minimum effective output capacitance required.
4. Increase the output capacitance appropriately due to the derating effect of applied dc voltage.

See [Equation 9](#), [Equation 10](#) and [Equation 11](#).

$$R_{LED} = \frac{\Delta V_F}{\Delta I_F} \times \# \text{ of LEDs} \quad (9)$$

$$Z_{COUT} = \frac{R_{LED} \times I_{LED(ripple)}}{I_{L(ripple)} - I_{LED(ripple)}} \quad (10)$$

$$C_{OUT} = \frac{1}{2\pi \times f_{SW} \times Z_{COUT}} \quad (11)$$

Once the output capacitor is chosen, [Equation 12](#) can be used to estimate the peak-to-peak ripple current through the LED string.

$$I_{LED(ripple)} = \frac{Z_{COUT} \times I_{L(ripple)}}{Z_{COUT} + R_{LED}} \quad (12)$$

An OSRAM IR LED, SFH4715A, is used here. The dynamic resistance of this LED is 0.25Ω at 1.5-A forward current. In this design, a 10- μ F, 35-V X7R ceramic capacitor is chosen, the part number is GRM32ER7YA106KA12L, from muRata. The calculated ripple current of the LED is about 20 mA.

9.2.1.2.4 FB Pin RC Filter Selection

The RC filter comprising R_F and C_F and connected between the sense resistor and the FB pin is used to generate a pole for loop stability purposes. Moving this pole can adjust loop bandwidth. The suggested frequency of the pole is 2 kHz in analog dimming mode and 4 kHz in PWM dimming mode. Use [Equation 13](#) to choose R_F and C_F . Due to the dc offset current of the internal amplifier, the suggested value of R_F is less than 1 k Ω to minimize the effect on LED current-regulation accuracy.

$$C_F = \frac{1}{2\pi \times R_F \times f_{POLE}} \quad (13)$$

Analog dimming mode is implemented in this design. Choose the pole at around 2 kHz, with 910 Ω as the filter resistor; then the calculated filter capacitance is 87 nF. An 82 nF capacitor is chosen for this filter.

9.2.1.2.5 Sense Resistor Selection

The maximum target LED current at 100% PWM duty is 1.5 A, and the corresponding V_{REF} is 200 mV. Using [Equation 1](#), calculate the needed sense resistance at 133 m Ω . Pay close attention to the power consumption of the sense resistor in this design at 300 mW, and make sure the chosen resistor has enough margin in its power rating.

9.2.1.3 Application Curves

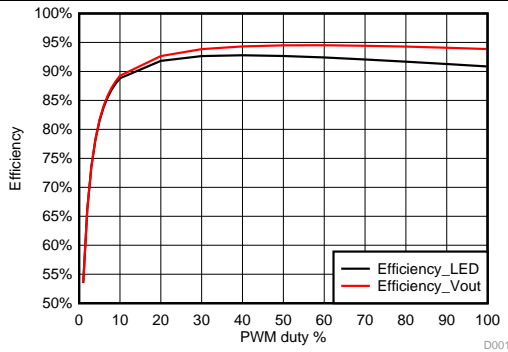
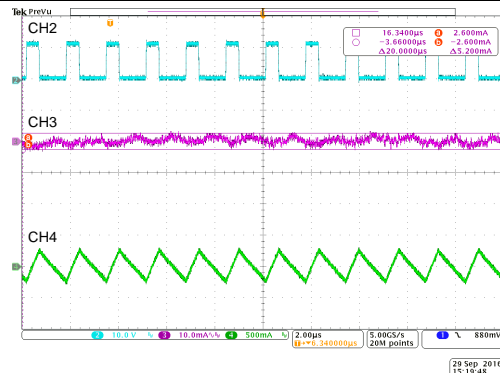
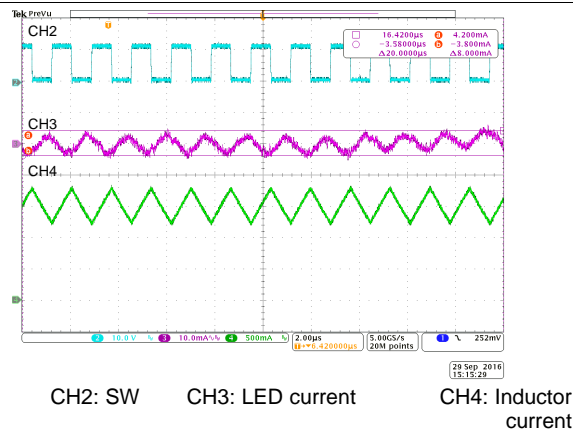

Figure 22. Efficiency



CH2: SW CH3: LED current CH4: Inductor current (AC-coupled)

Figure 23. LED Current Ripple at 1% PWM Duty Cycle



CH2: SW CH3: LED current CH4: Inductor current (AC-coupled)

Figure 24. LED Current Ripple at 100% PWM Duty Cycle

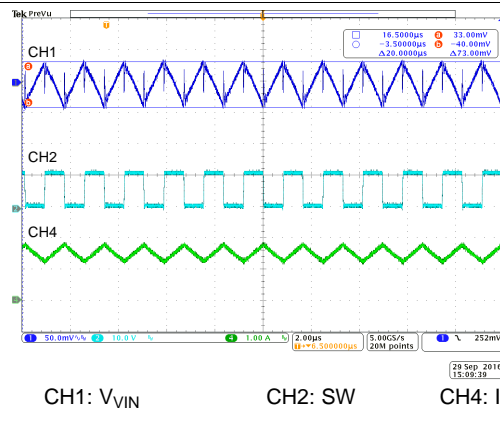

CH1: VIN CH2: SW CH4: Inductor current (AC-coupled)

Figure 25. Input Voltage Ripple at 100% PWM Duty Cycle

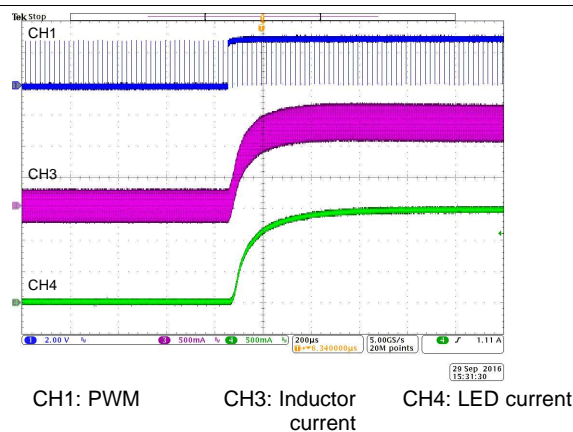

Figure 26. LED Current Transient as PWM Duty Cycle Changes From 1% to 99%

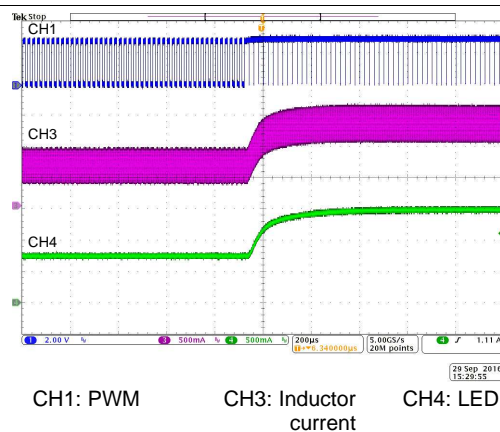

Figure 27. LED Current Transient as PWM Duty Cycle Changes From 50% to 99%

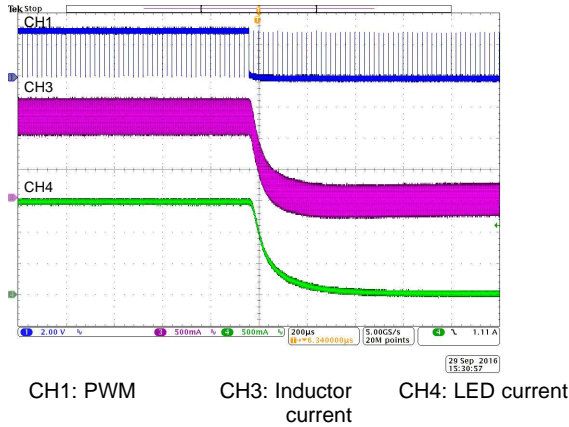

Figure 28. LED Current Transient as PWM Duty Cycle Changes From 99% to 1%

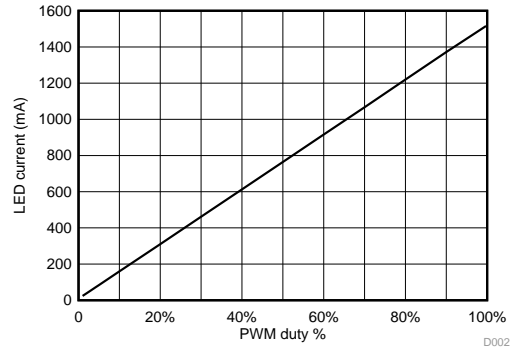

Figure 29. LED Current vs PWM Duty Cycle

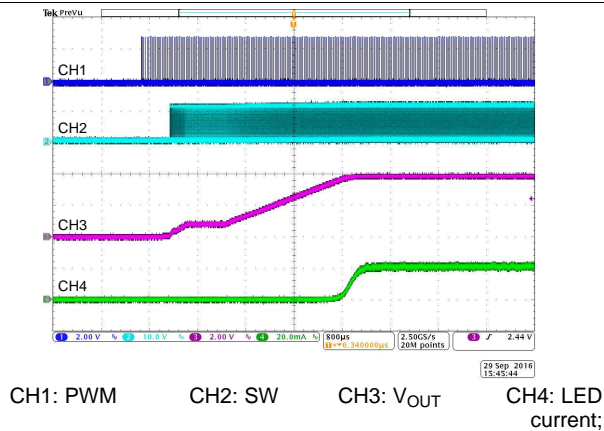

Figure 30. Start-Up at 1% PWM Duty Cycle and 50 kHz

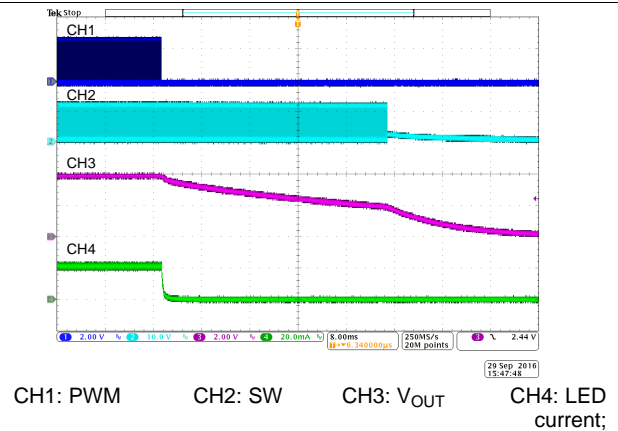

Figure 31. Shutdown at 1% PWM Duty Cycle and 50 kHz

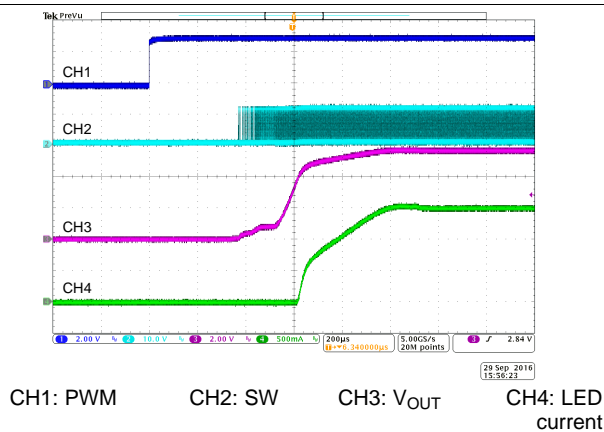

Figure 32. Start-Up at 100% PWM Duty Cycle

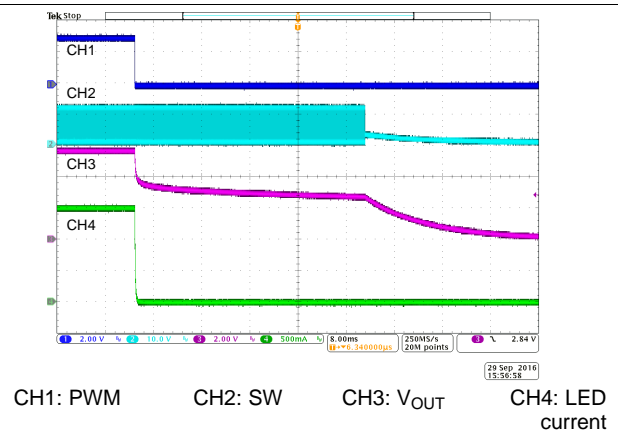

Figure 33. Shutdown at 100% PWM Duty Cycle

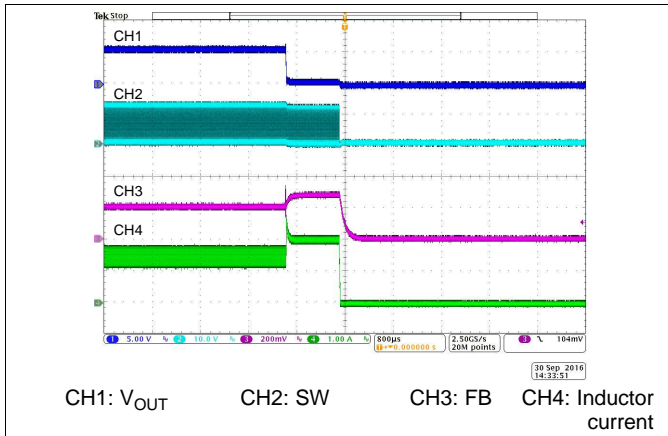

Figure 34. LED Short Protection (100% PWM Duty Cycle) of TPS54200

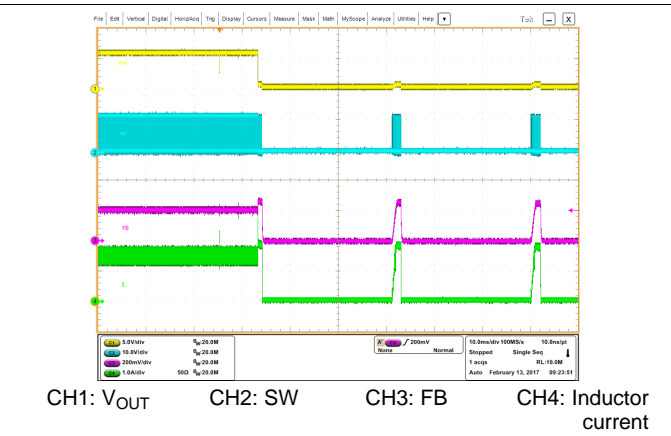

Figure 35. LED Short Protection (100% PWM Duty Cycle) of TPS54201

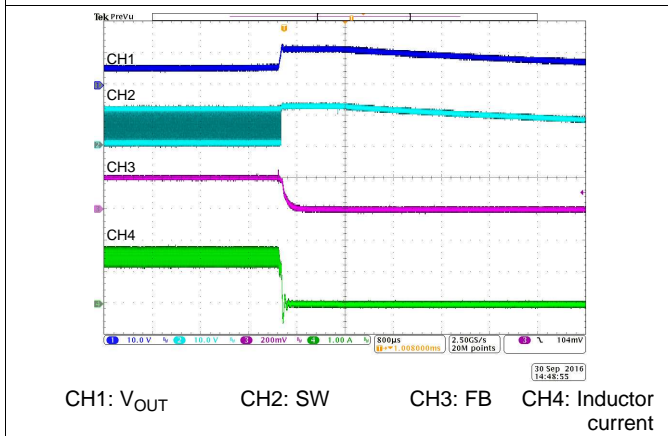

Figure 36. LED Open Protection (100% PWM Duty Cycle) of TPS54200

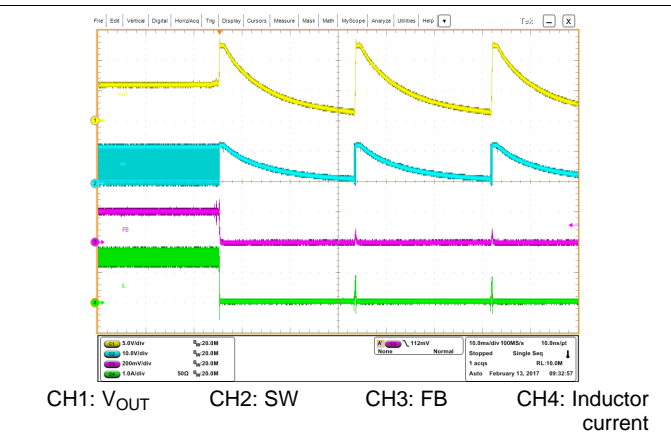

Figure 37. LED Open Protection (100% PWM Duty Cycle) of TPS54201

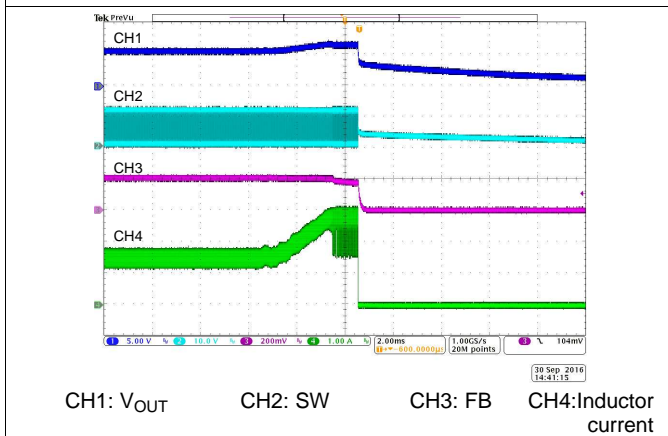

Figure 38. Sense Resistor Short Protection (100% PWM Duty Cycle) of TPS54200

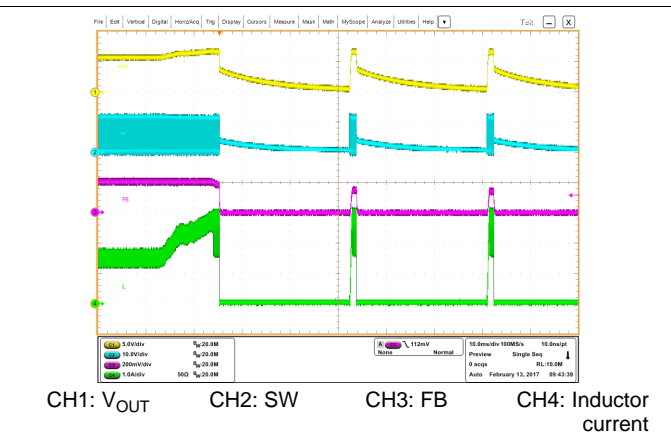
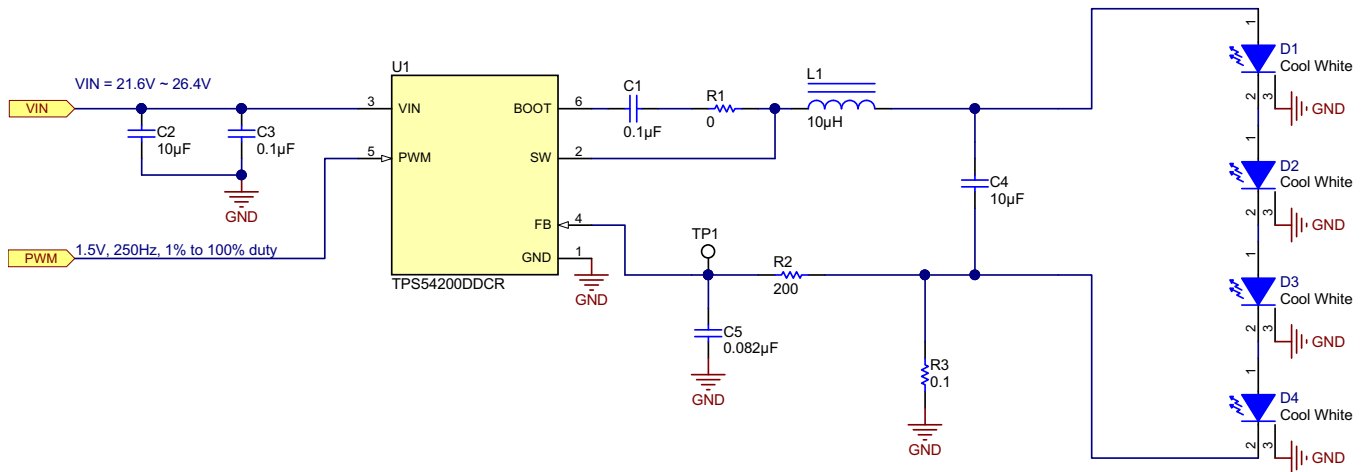

Figure 39. Sense-Resistor Short Protection (100% PWM Duty Cycle) of TPS54201

9.2.2 TPS5420x 24-V Input, 1-A, 4-Piece WLED Driver With PWM Dimming



Copyright © 2016, Texas Instruments Incorporated

Figure 40. 24-V Input, 1-A, 4-Piece WLED Driver With PWM Dimming Reference Design

9.2.2.1 Design Requirements

For this design example, use the parameters in [Table 3](#).

Table 3. Design Parameters

PARAMETER	VALUE
Input voltage range	21.6 V to 26.4 V
LED string forward voltage	11.6-V stack
Output voltage	11.7 V
LED current at 100% PWM duty cycle	1 A
LED current ripple	30 mA or less
Input voltage ripple	400 mV or less
PWM dimming range	1% to 100%, 1.5 V, 250 Hz

9.2.2.2 Detailed Design Procedure

The detailed design process in this example is basically the same with that shown in the previous design example. Following are the design results.

9.2.2.2.1 Inductor Selection

A Cree white LED XLampXML is used. According to the LED manufacturer's data sheet, this LED has 2.9-V forward voltage at 1-A current, so $V_{OUT} = 2.9 \text{ V} \times 4 + 0.1 \text{ V} = 11.7 \text{ V}$. Choose $K_{IND} = 0.3$, which gives a 36- μH inductance. With this inductance, the ripple current on the inductor is only 0.3-A peak-to-peak, which is too conservative and increases total system cost and size.

For this application, with concerns about system cost and size taken into account, decide the inductance by choosing a larger peak-to-peak inductor ripple current. To choose a proper peak-to-peak inductor ripple, the low-side FET sink current limit should not be exceeded when the converter works in a no-load condition. To meet this requirement, half of the peak-to-peak inductor ripple must be lower than that limit. Another consideration with this larger peak-to-peak ripple current is the increased core loss and copper loss in the inductor, which is also acceptable. Once this peak-to-peak inductor ripple current is chosen, [Equation 14](#) can be used to calculate the required inductance.

$$L_{MIN} = \frac{V_{OUT} \times (V_{IN(max)} - V_{OUT})}{V_{IN(max)} \times I_{L(ripple)} \times f_{SW}}$$

where

- $I_{L(RIPPLE)}$ is the peak-to-peak inductor ripple current. (14)

Choose 1-A peak-to-peak inductor ripple current, and half of the current is 0.5 A, much lower than the minimum low-side sink current limit of 1.25 A. The calculated inductance is 10.9 μH . Choose a 10- μH inductor with part number 744066100 from Wurth. The ripple, peak, and rms currents of the inductor are 1.09 A, 1.54 A, and 1.05 A, respectively. The chosen inductor has ample margin in this design.

9.2.2.2.2 Input Capacitor Selection

In this design, a 10- μF , 35-V X7R ceramic capacitor, part number GRM32ER7YA106KA12L from muRata, is chosen. This yields around 70-mV input-ripple voltage. The calculated rms input ripple current is 0.5 A, well below the ripple-current rating of the capacitor.

9.2.2.2.3 Output Capacitor Selection

The dynamic resistance of this LED is 0.184 Ω at 1-A forward current. In this design, choose a 10- μF , 35-V X7R ceramic capacitor, part number GRM32ER7YA106KA12L from muRata. The calculated ripple current of the LED is about 40 mA.

9.2.2.2.4 FB Pin RC Filter Selection

PWM dimming mode is implemented in this design. Choose the pole at around 4 kHz, and choose 475 Ω as the filter resistor. With those values, an 82 nF capacitor should be chosen for this filter. To get a faster loop response, choose a smaller filter resistor. In this design, 200 Ω was chosen to get a pole at approximately 10 kHz.

9.2.2.2.5 Sense Resistor Selection

The maximum target LED current at 100% PWM duty cycle is 1 A, and the corresponding V_{REF} is 100 mV. By using [Equation 1](#), one can calculate the needed sense resistance of 100 m Ω . Pay close attention to the power consumption of the sense resistor in this design at 100 mW. Make sure the chosen resistor has enough margin in the power rating.

9.2.2.3 Application Curves

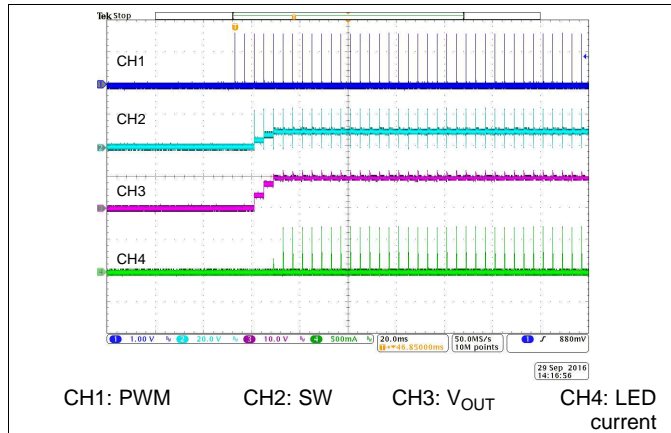

Figure 41. Start-Up at 1% PWM Duty Cycle and 250 Hz

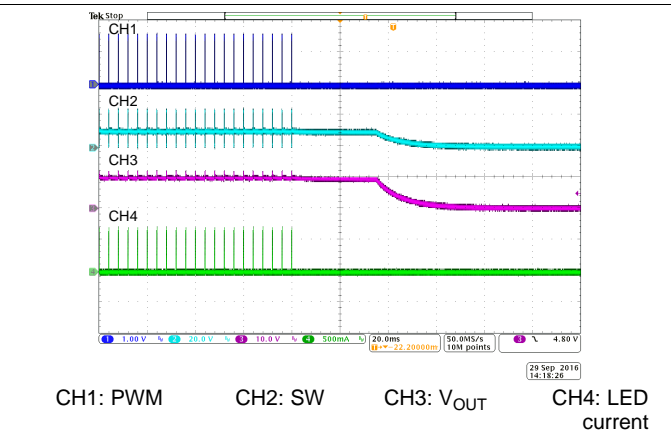

Figure 42. Shutdown at 1% PWM Duty Cycle and 250 Hz

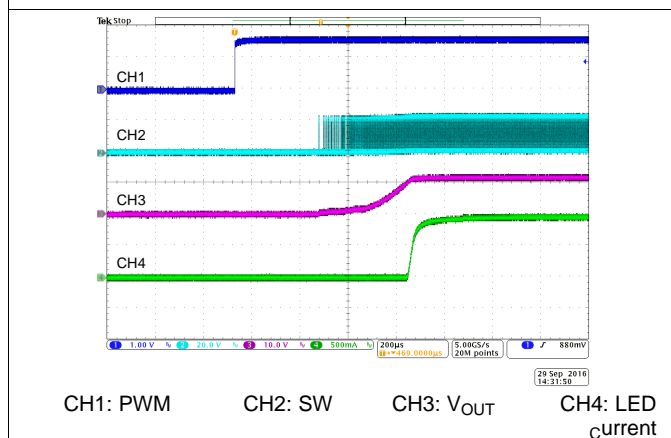

Figure 43. Start-Up at 100% PWM Duty Cycle

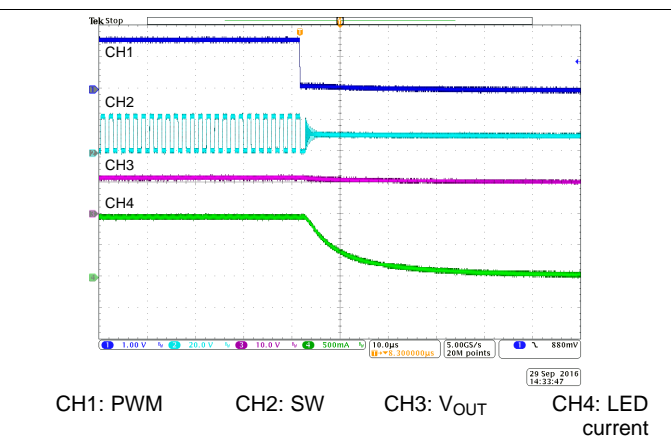

Figure 44. Shutdown at 100% PWM Duty Cycle

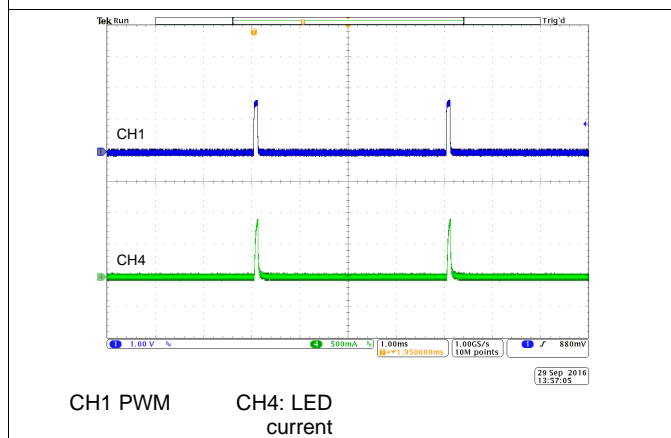

Figure 45. PWM Dimming With 2% Duty Cycle and 250 Hz

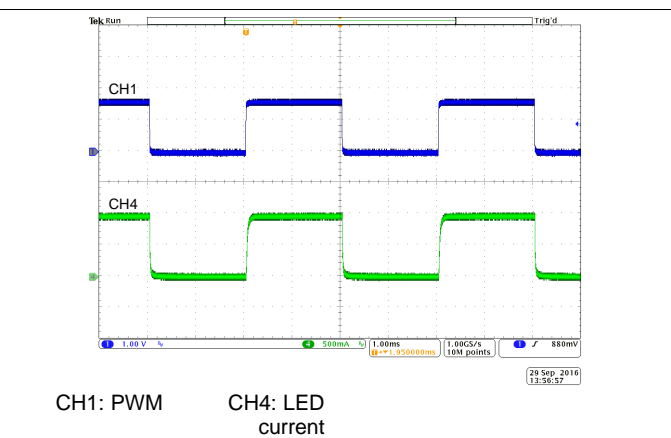
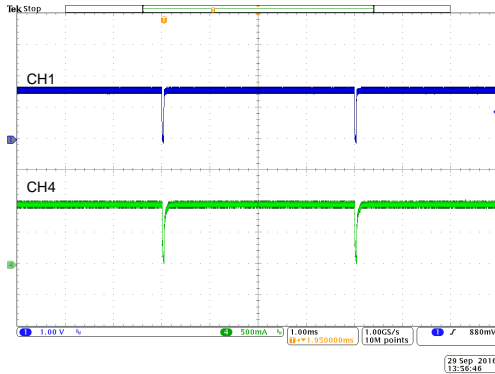
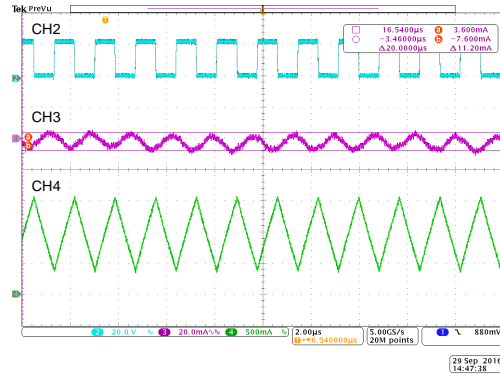

Figure 46. PWM Dimming With 50% Duty Cycle and 250 Hz



CH1: PWM CH4: LED current

Figure 47. PWM Dimming With 99% Duty Cycle and 250 Hz



CH2: SW CH3: LED current (AC-coupled) CH4: Inductor current

Figure 48. LED Current Ripple at 100% PWM Duty Cycle

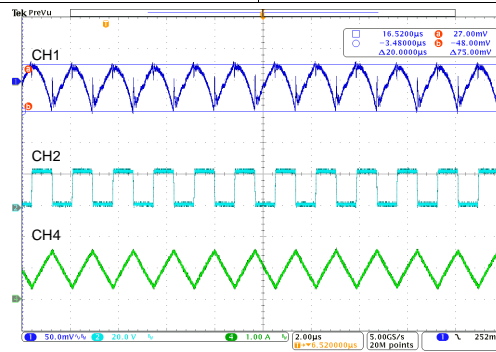

CH1: V_{VIN} (AC-coupled) CH2: SW CH4: Inductor current

Figure 49. Input Voltage Ripple at 100% PWM Duty Cycle

10 Power Supply Recommendations

The devices are designed to operate from an input voltage supply range between 4.5 V and 28 V. This input supply must be well regulated. If the input supply is located more than a few inches from the device or converter, additional bulk capacitance may be required in addition to the ceramic bypass capacitors.

11 Layout

The TPS5420x requires a proper layout for optimal performance. The following section gives some guidelines to help ensure a proper layout.

11.1 Layout Guidelines

An example of a proper layout for the TPS5420x is shown in [Figure 50](#).

- Creating a large GND plane for good electrical and thermal performance is important.
- The VIN and GND traces should be as wide as possible to reduce trace impedance. The added width also provides excellent heat dissipation.
- Thermal vias can be used to connect the topside GND plane to additional printed-circuit board (PCB) layers for heat dissipation and grounding.
- The input capacitors must be located as close as possible to the VIN pin and the GND pin.
- The SW trace must be kept as short as possible to minimize radiated noise and EMI.
- Do not allow switching current to flow under the device.
- The FB trace should be kept as short as possible and placed away from the high-voltage switching trace and the ground shield.
- In higher-current applications, routing the load current of the current-sense resistor to the junction of the input capacitor and GND node may be necessary.

11.2 Layout Example

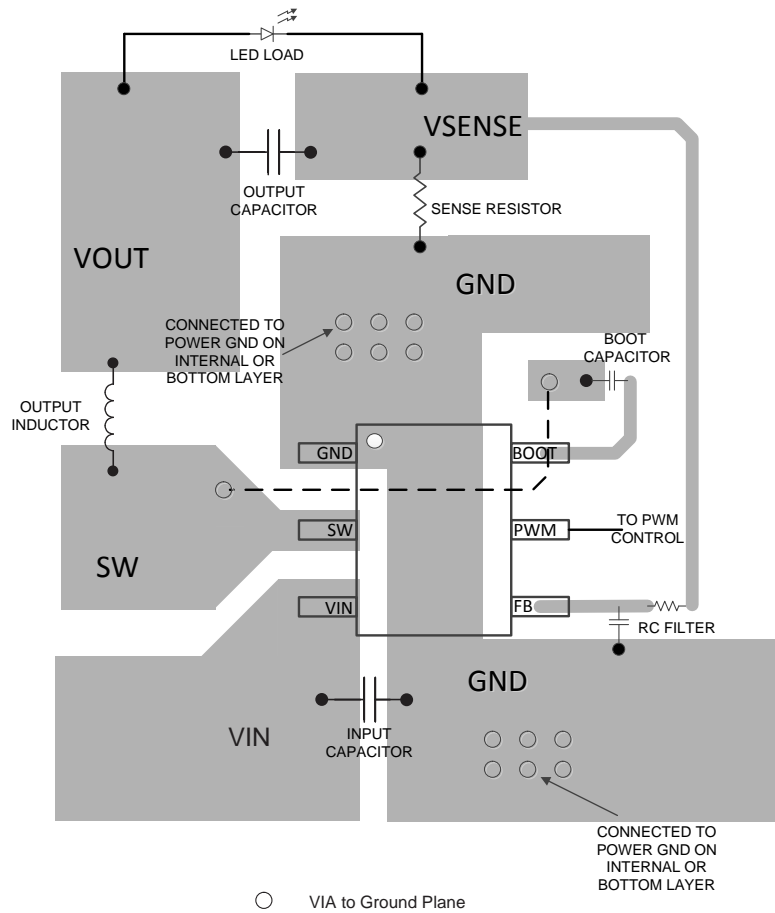

Figure 50. Layout Example

12 Device and Documentation Support

12.1 Device Support

12.1.1 Third-Party Products Disclaimer

TI'S PUBLICATION OF INFORMATION REGARDING THIRD-PARTY PRODUCTS OR SERVICES DOES NOT CONSTITUTE AN ENDORSEMENT REGARDING THE SUITABILITY OF SUCH PRODUCTS OR SERVICES OR A WARRANTY, REPRESENTATION OR ENDORSEMENT OF SUCH PRODUCTS OR SERVICES, EITHER ALONE OR IN COMBINATION WITH ANY TI PRODUCT OR SERVICE.

12.2 Documentation Support

12.2.1 Related Links

The table below lists quick access links. Categories include technical documents, support and community resources, tools and software, and quick access to order now.

Table 4. Related Links

PARTS	PRODUCT FOLDER	ORDER NOW	TECHNICAL DOCUMENTS	TOOLS & SOFTWARE	SUPPORT & COMMUNITY
TPS54200	Click here	Click here	Click here	Click here	Click here
TPS54201	Click here	Click here	Click here	Click here	Click here

12.3 Receiving Notification of Documentation Updates

To receive notification of documentation updates, navigate to the device product folder on ti.com. In the upper right corner, click on *Alert me* to register and receive a weekly digest of any product information that has changed. For change details, review the revision history included in any revised document.

12.4 Community Resources

The following links connect to TI community resources. Linked contents are provided "AS IS" by the respective contributors. They do not constitute TI specifications and do not necessarily reflect TI's views; see TI's [Terms of Use](#).

TI E2E™ Online Community *TI's Engineer-to-Engineer (E2E) Community*. Created to foster collaboration among engineers. At e2e.ti.com, you can ask questions, share knowledge, explore ideas and help solve problems with fellow engineers.

Design Support *TI's Design Support* Quickly find helpful E2E forums along with design support tools and contact information for technical support.

12.5 Trademarks

E2E is a trademark of Texas Instruments.
All other trademarks are the property of their respective owners.

12.6 Electrostatic Discharge Caution



This integrated circuit can be damaged by ESD. Texas Instruments recommends that all integrated circuits be handled with appropriate precautions. Failure to observe proper handling and installation procedures can cause damage.

ESD damage can range from subtle performance degradation to complete device failure. Precision integrated circuits may be more susceptible to damage because very small parametric changes could cause the device not to meet its published specifications.

12.7 Glossary

SLYZ022 — *TI Glossary*.

This glossary lists and explains terms, acronyms, and definitions.

13 Mechanical, Packaging, and Orderable Information

The following pages include mechanical, packaging, and orderable information. This information is the most-current data available for the designated devices. This data is subject to change without notice and without revision of this document. For browser-based versions of this data sheet, see the left-hand navigation pane.

PACKAGING INFORMATION

Orderable Device	Status (1)	Package Type	Package Drawing	Pins	Package Qty	Eco Plan (2)	Lead finish/ Ball material (6)	MSL Peak Temp (3)	Op Temp (°C)	Device Marking (4/5)	Samples
TPS54200DDCR	ACTIVE	SOT-23-THIN	DDC	6	3000	RoHS & Green	Call TI SN	Level-1-260C-UNLIM	-40 to 85	4200	Samples
TPS54200DDCT	ACTIVE	SOT-23-THIN	DDC	6	250	RoHS & Green	Call TI SN	Level-1-260C-UNLIM	-40 to 85	4200	Samples
TPS54201DDCR	ACTIVE	SOT-23-THIN	DDC	6	3000	RoHS & Green	Call TI SN	Level-1-260C-UNLIM	-40 to 125	4201	Samples
TPS54201DDCT	ACTIVE	SOT-23-THIN	DDC	6	250	RoHS & Green	Call TI SN	Level-1-260C-UNLIM	-40 to 125	4201	Samples

(1) The marketing status values are defined as follows:

ACTIVE: Product device recommended for new designs.

LIFEBUY: TI has announced that the device will be discontinued, and a lifetime-buy period is in effect.

NRND: Not recommended for new designs. Device is in production to support existing customers, but TI does not recommend using this part in a new design.

PREVIEW: Device has been announced but is not in production. Samples may or may not be available.

OBSELETE: TI has discontinued the production of the device.

(2) **RoHS:** TI defines "RoHS" to mean semiconductor products that are compliant with the current EU RoHS requirements for all 10 RoHS substances, including the requirement that RoHS substance do not exceed 0.1% by weight in homogeneous materials. Where designed to be soldered at high temperatures, "RoHS" products are suitable for use in specified lead-free processes. TI may reference these types of products as "Pb-Free".

RoHS Exempt: TI defines "RoHS Exempt" to mean products that contain lead but are compliant with EU RoHS pursuant to a specific EU RoHS exemption.

Green: TI defines "Green" to mean the content of Chlorine (Cl) and Bromine (Br) based flame retardants meet JS709B low halogen requirements of <=1000ppm threshold. Antimony trioxide based flame retardants must also meet the <=1000ppm threshold requirement.

(3) MSL, Peak Temp. - The Moisture Sensitivity Level rating according to the JEDEC industry standard classifications, and peak solder temperature.

(4) There may be additional marking, which relates to the logo, the lot trace code information, or the environmental category on the device.

(5) Multiple Device Markings will be inside parentheses. Only one Device Marking contained in parentheses and separated by a "-" will appear on a device. If a line is indented then it is a continuation of the previous line and the two combined represent the entire Device Marking for that device.

(6) Lead finish/Ball material - Orderable Devices may have multiple material finish options. Finish options are separated by a vertical ruled line. Lead finish/Ball material values may wrap to two lines if the finish value exceeds the maximum column width.

Important Information and Disclaimer:The information provided on this page represents TI's knowledge and belief as of the date that it is provided. TI bases its knowledge and belief on information provided by third parties, and makes no representation or warranty as to the accuracy of such information. Efforts are underway to better integrate information from third parties. TI has taken and

continues to take reasonable steps to provide representative and accurate information but may not have conducted destructive testing or chemical analysis on incoming materials and chemicals. TI and TI suppliers consider certain information to be proprietary, and thus CAS numbers and other limited information may not be available for release.

In no event shall TI's liability arising out of such information exceed the total purchase price of the TI part(s) at issue in this document sold by TI to Customer on an annual basis.

TAPE AND REEL INFORMATION

QUADRANT ASSIGNMENTS FOR PIN 1 ORIENTATION IN TAPE



*All dimensions are nominal

Device	Package Type	Package Drawing	Pins	SPQ	Reel Diameter (mm)	Reel Width W1 (mm)	A0 (mm)	B0 (mm)	K0 (mm)	P1 (mm)	W (mm)	Pin1 Quadrant
TPS54200DDCR	SOT-23-THIN	DDC	6	3000	180.0	8.4	3.2	3.2	1.4	4.0	8.0	Q3
TPS54200DDCR	SOT-23-THIN	DDC	6	3000	180.0	9.5	3.17	3.1	1.1	4.0	8.0	Q3
TPS54200DDCT	SOT-23-THIN	DDC	6	250	180.0	8.4	3.2	3.2	1.4	4.0	8.0	Q3
TPS54200DDCT	SOT-23-THIN	DDC	6	250	180.0	9.5	3.17	3.1	1.1	4.0	8.0	Q3
TPS54201DDCR	SOT-23-THIN	DDC	6	3000	180.0	8.4	3.2	3.2	1.4	4.0	8.0	Q3
TPS54201DDCT	SOT-23-THIN	DDC	6	250	180.0	8.4	3.2	3.2	1.4	4.0	8.0	Q3
TPS54201DDCT	SOT-23-THIN	DDC	6	250	180.0	9.5	3.17	3.1	1.1	4.0	8.0	Q3

TAPE AND REEL BOX DIMENSIONS

*All dimensions are nominal

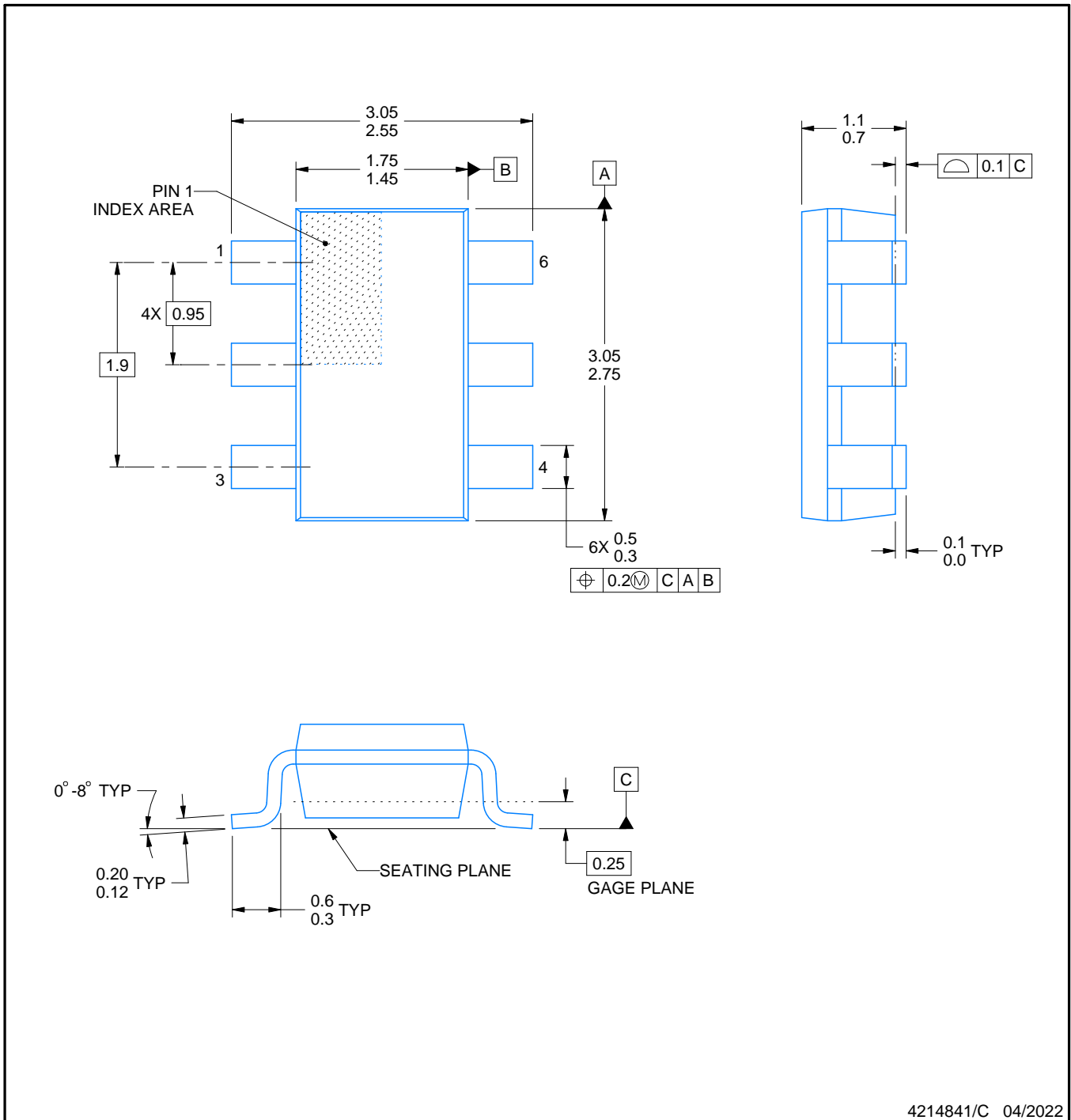
Device	Package Type	Package Drawing	Pins	SPQ	Length (mm)	Width (mm)	Height (mm)
TPS54200DDCR	SOT-23-THIN	DDC	6	3000	210.0	185.0	35.0
TPS54200DDCR	SOT-23-THIN	DDC	6	3000	184.0	184.0	19.0
TPS54200DDCT	SOT-23-THIN	DDC	6	250	210.0	185.0	35.0
TPS54200DDCT	SOT-23-THIN	DDC	6	250	184.0	184.0	19.0
TPS54201DDCR	SOT-23-THIN	DDC	6	3000	210.0	185.0	35.0
TPS54201DDCT	SOT-23-THIN	DDC	6	250	210.0	185.0	35.0
TPS54201DDCT	SOT-23-THIN	DDC	6	250	184.0	184.0	19.0



4214841/C 04/2022

NOTES:

1. All linear dimensions are in millimeters. Any dimensions in parenthesis are for reference only. Dimensioning and tolerancing per ASME Y14.5M.
2. This drawing is subject to change without notice.
3. Reference JEDEC MO-193.

EXAMPLE BOARD LAYOUT

DDC0006A

SOT-23 - 1.1 max height

SMALL OUTLINE TRANSISTOR

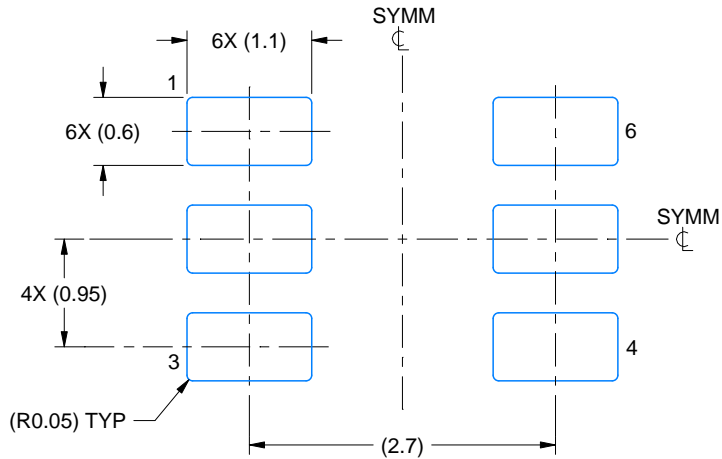

LAND PATTERN EXAMPLE
EXPLODED METAL SHOWN
SCALE:15X



SOLDEMASK DETAILS

4214841/C 04/2022

NOTES: (continued)

- 4. Publication IPC-7351 may have alternate designs.
- 5. Solder mask tolerances between and around signal pads can vary based on board fabrication site.

EXAMPLE STENCIL DESIGN

DDC0006A

SOT-23 - 1.1 max height

SMALL OUTLINE TRANSISTOR

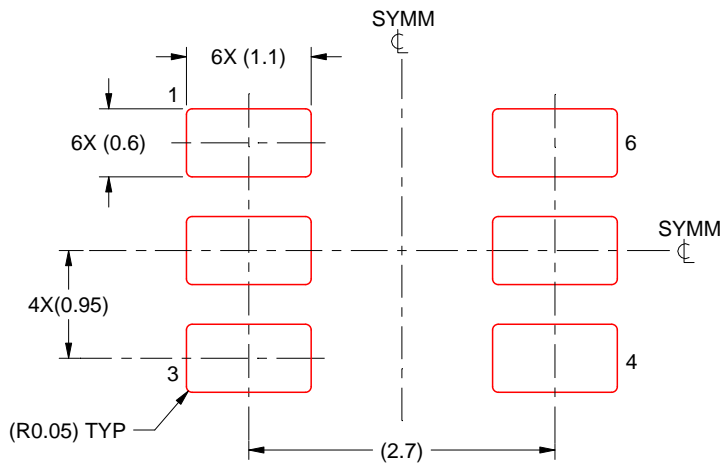

SOLDER PASTE EXAMPLE
BASED ON 0.125 THICK STENCIL
SCALE:15X

4214841/C 04/2022

NOTES: (continued)

6. Laser cutting apertures with trapezoidal walls and rounded corners may offer better paste release. IPC-7525 may have alternate design recommendations.
7. Board assembly site may have different recommendations for stencil design.

IMPORTANT NOTICE AND DISCLAIMER

TI PROVIDES TECHNICAL AND RELIABILITY DATA (INCLUDING DATA SHEETS), DESIGN RESOURCES (INCLUDING REFERENCE DESIGNS), APPLICATION OR OTHER DESIGN ADVICE, WEB TOOLS, SAFETY INFORMATION, AND OTHER RESOURCES "AS IS" AND WITH ALL FAULTS, AND DISCLAIMS ALL WARRANTIES, EXPRESS AND IMPLIED, INCLUDING WITHOUT LIMITATION ANY IMPLIED WARRANTIES OF MERCHANTABILITY, FITNESS FOR A PARTICULAR PURPOSE OR NON-INFRINGEMENT OF THIRD PARTY INTELLECTUAL PROPERTY RIGHTS.

These resources are intended for skilled developers designing with TI products. You are solely responsible for (1) selecting the appropriate TI products for your application, (2) designing, validating and testing your application, and (3) ensuring your application meets applicable standards, and any other safety, security, regulatory or other requirements.

These resources are subject to change without notice. TI grants you permission to use these resources only for development of an application that uses the TI products described in the resource. Other reproduction and display of these resources is prohibited. No license is granted to any other TI intellectual property right or to any third party intellectual property right. TI disclaims responsibility for, and you will fully indemnify TI and its representatives against, any claims, damages, costs, losses, and liabilities arising out of your use of these resources.

TI's products are provided subject to [TI's Terms of Sale](#) or other applicable terms available either on ti.com or provided in conjunction with such TI products. TI's provision of these resources does not expand or otherwise alter TI's applicable warranties or warranty disclaimers for TI products.

TI objects to and rejects any additional or different terms you may have proposed.

Mailing Address: Texas Instruments, Post Office Box 655303, Dallas, Texas 75265
Copyright © 2022, Texas Instruments Incorporated