



## Precision Dual *Difet*<sup>®</sup> Operational Amplifier

### FEATURES

- Very Low Noise:  $8\text{nV}/\sqrt{\text{Hz}}$  at 10kHz
- Low  $V_{OS}$ : 1mV max
- Low Drift:  $10\mu\text{V}/^\circ\text{C}$  max
- Low  $I_B$ : 10pA max
- Fast Settling Time:  $2\mu\text{s}$  to 0.01%
- Unity-Gain Stable

### APPLICATIONS

- Data Acquisition
- DAC Output Amplifiers
- Optoelectronics
- High-Impedance Sensor Amps
- High-Performance Audio Circuitry
- Medical Equipment, CT Scanners

### DESCRIPTION

The OPA2107 dual operational amplifier provides precision *Difet* performance with the cost and space savings of a dual op amp. It is useful in a wide range of precision and low-noise analog circuitry and can be used to upgrade the performance of designs currently using BIFET<sup>®</sup> type amplifiers.

The OPA2107 is fabricated on a proprietary dielectrically isolated (*Difet*) process. This holds input bias currents to very low levels without sacrificing other important parameters, such as input offset voltage, drift and noise. Laser-trimmed input circuitry yields excellent dc performance. Superior dynamic performance is achieved, yet quiescent current is held to under 2.5mA per amplifier. The OPA2107 is unity-gain stable.

The OPA2107 is available in DIP-8 and SO-8 packages.

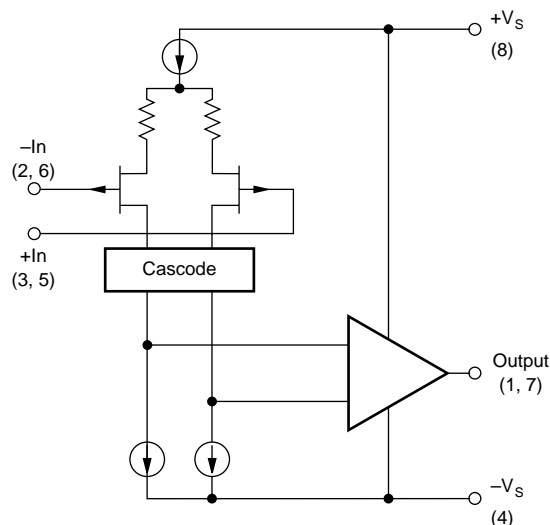

Please be aware that an important notice concerning availability, standard warranty, and use in critical applications of Texas Instruments semiconductor products and disclaimers thereto appears at the end of this data sheet.

All trademarks are the property of their respective owners.

## ABSOLUTE MAXIMUM RATINGS<sup>(1)</sup>

Supply Voltage .....	±18V
Input Voltage Range .....	±V <sub>S</sub> ±2V
Differential Input Voltage .....	Total V <sub>S</sub> ±4V
Operating Temperature	
P and U Packages .....	-25°C to +85°C
Storage Temperature	
P and U Packages .....	-40°C to +125°C
Output Short Circuit to Ground (T <sub>A</sub> = +25°C) .....	Continuous
Junction Temperature .....	+175°C
Lead Temperature	
P Package (soldering, 10s) .....	+300°C
U Package, SOIC (3s) .....	+260°C

NOTE: Stresses above these ratings may cause permanent damage.



## ELECTROSTATIC DISCHARGE SENSITIVITY

This integrated circuit can be damaged by ESD. Texas Instruments recommends that all integrated circuits be handled with appropriate precautions. Failure to observe proper handling and installation procedures can cause damage.

ESD damage can range from subtle performance degradation to complete device failure. Precision integrated circuits may be more susceptible to damage because very small parametric changes could cause the device not to meet its published specifications.

## PIN CONFIGURATION

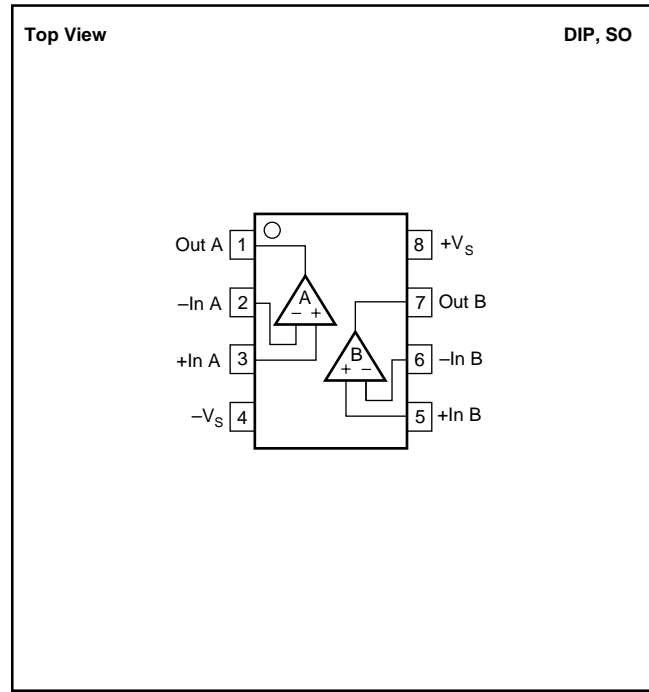

## PACKAGE/ORDERING INFORMATION

PRODUCT	PACKAGE-LEAD	PACKAGE DESIGNATOR <sup>(1)</sup>	SPECIFIED TEMPERATURE RANGE	PACKAGE MARKING	ORDERING NUMBER	TRANSPORT MEDIA, QUANTITY
OPA2107	DIP-8	P	-25°C to +85°C	OPA2107AP	OPA2107AP	Tube, 50
OPA2107	SO-8	D	-25°C to +85°C	OPA2107AU	OPA2107AU	Tube, 100
"	"	"	"	"	OPA2107AU/2K5	Tape and Reel, 2500

NOTE: (1) For the most current specifications and package information, refer to our web site at [www.ti.com](http://www.ti.com).

# ELECTRICAL CHARACTERISTICS

At  $T_A = +25^\circ\text{C}$ ,  $V_S = \pm 15\text{V}$ , unless otherwise noted.

PARAMETER	CONDITION	OPA2107AP, AU			UNITS
		MIN	TYP	MAX	
<b>OFFSET VOLTAGE<sup>(1)</sup></b> Input Offset Voltage Over Specified Temperature Average Drift Over Specified Temperature Power Supply Rejection	$V_{CM} = 0\text{V}$  $V_S = \pm 10$ to $\pm 18\text{V}$		0.1 0.5 3 96	1 2 10	mV mV $\mu\text{V}/^\circ\text{C}$ dB
<b>INPUT BIAS CURRENT<sup>(1)</sup></b> Input Bias Current Over Specified Temperature Input Offset Current Over Specified Temperature	$V_{CM} = 0\text{V}$  $V_{CM} = 0\text{V}$		4 0.25 1	10 1.5 8 1	pA nA pA nA
<b>INPUT NOISE</b> Voltage: $f = 10\text{Hz}$ $f = 100\text{Hz}$ $f = 1\text{kHz}$ $f = 10\text{kHz}$ BW = 0.1 to 10Hz BW = 10 to 10kHz Current: $f = 0.1\text{Hz}$ thru 20kHz BW = 0.1Hz to 10Hz	$R_S = 0$		30 12 9 8 1.2 0.85 1.2 23		$\text{nV}/\sqrt{\text{Hz}}$ $\text{nV}/\sqrt{\text{Hz}}$ $\text{nV}/\sqrt{\text{Hz}}$ $\text{nV}/\sqrt{\text{Hz}}$ $\mu\text{Vp-p}$ $\mu\text{Vrms}$ $\text{fA}/\sqrt{\text{Hz}}$ $\text{fAp-p}$
<b>INPUT IMPEDANCE</b> Differential Common-Mode			$10^{13} \parallel 2$ $10^{14} \parallel 4$		$\Omega \parallel \text{pF}$ $\Omega \parallel \text{pF}$
<b>INPUT VOLTAGE RANGE</b> Common-Mode Input Range Over Specified Temperature Common-Mode Rejection	$V_{CM} = \pm 10\text{V}$	$\pm 10.5$ $\pm 10.2$ 80	$\pm 11$ $\pm 10.5$ 94		V V dB
<b>OPEN-LOOP GAIN</b> Open-Loop Voltage Gain Over Specified Temperature	$V_O = \pm 10\text{V}$ , $R_L = 2\text{k}\Omega$	82 80	96 94		dB dB
<b>DYNAMIC RESPONSE</b> Slew Rate Settling Time: 0.1% 0.01% Gain Bandwidth Product THD + Noise Channel Separation	$G = +1$ $G = -1$ , 10V Step  $G = 100$ $G = +1$ , $f = 1\text{kHz}$ $f = 100\text{Hz}$ , $R_L = 2\text{k}\Omega$	13	18 1.5 2 4.5 0.001 120		V/ $\mu\text{s}$ $\mu\text{s}$ $\mu\text{s}$ MHz % dB
<b>POWER SUPPLY</b> Specified Operating Voltage Operating Voltage Range Current		$\pm 4.5$	$\pm 15$  $\pm 4.5$		V V mA
<b>OUTPUT</b> Voltage Output Over Specified Temperature Short Circuit Current Output Resistance, Open-Loop Capacitive Load Stability	$R_L = 2\text{k}\Omega$   1MHz $G = +1$	$\pm 11$ $\pm 10.5$ $\pm 10$	$\pm 12$ $\pm 11.5$ $\pm 40$ 70 1000		V V mA $\Omega$ pF
<b>TEMPERATURE RANGE</b> Specification Operating Storage Thermal Resistance ( $\theta_{JA}$ ) DIP-8 SO-8		-25 -25 -40		+85 +85 +125	$^\circ\text{C}$ $^\circ\text{C}$ $^\circ\text{C}$ $^\circ\text{C}/\text{W}$ $^\circ\text{C}/\text{W}$

NOTE: (1) Specified with devices fully warmed up.

# TYPICAL CHARACTERISTICS

$T_A = +25^\circ\text{C}$ ,  $V_S = \pm 15\text{V}$  unless otherwise noted.

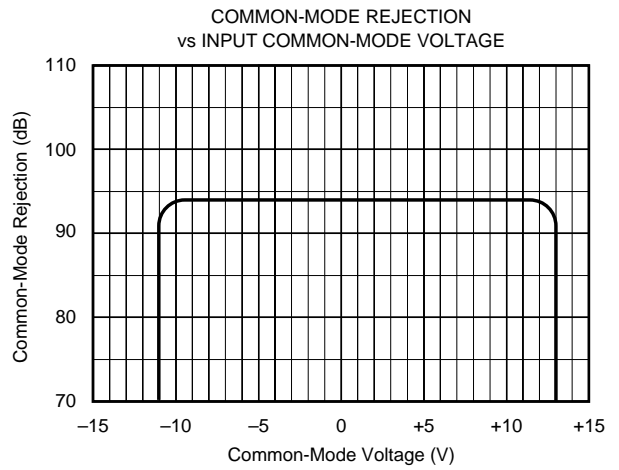
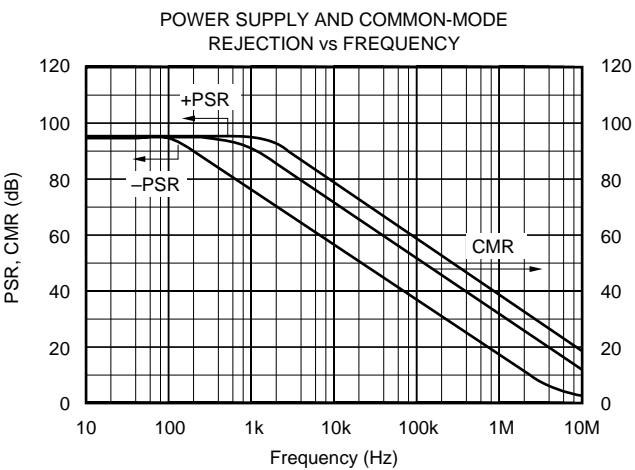
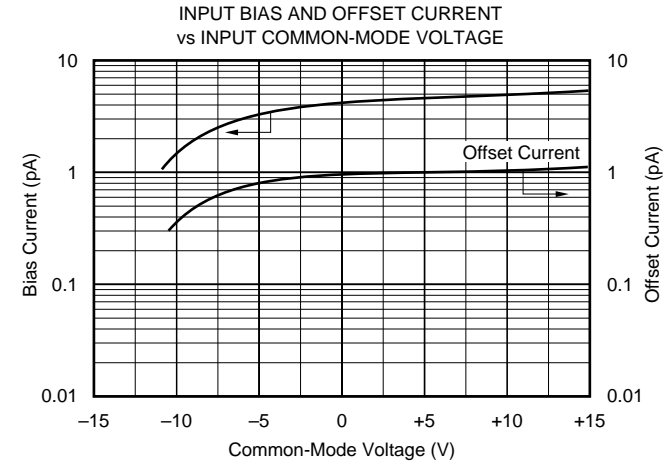
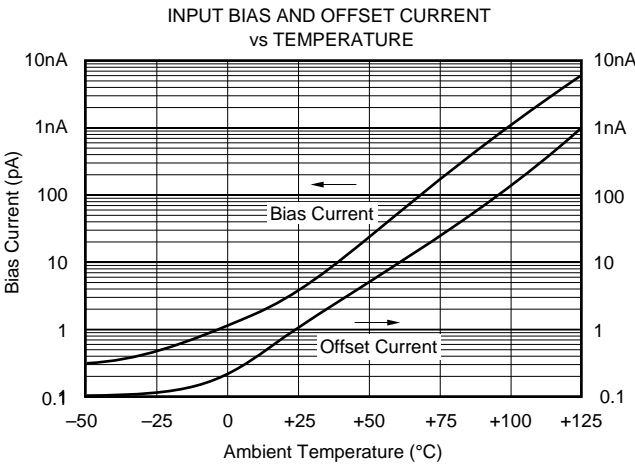
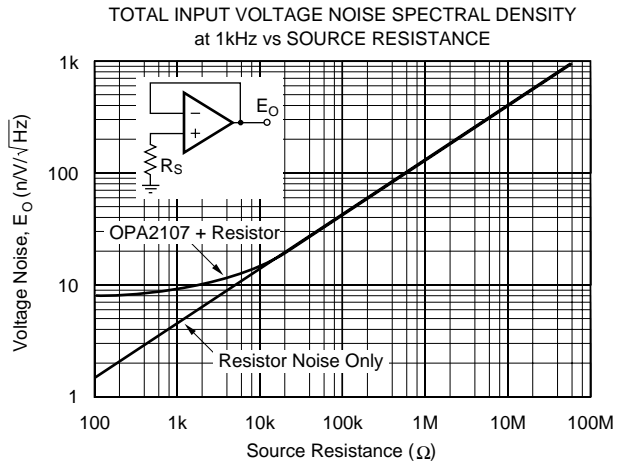
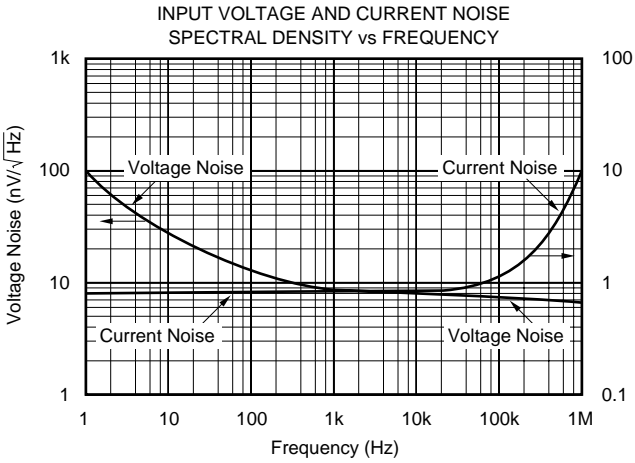

# TYPICAL CHARACTERISTICS (Cont.)

$T_A = +25^\circ\text{C}$ ,  $V_S = \pm 15\text{V}$  unless otherwise noted.

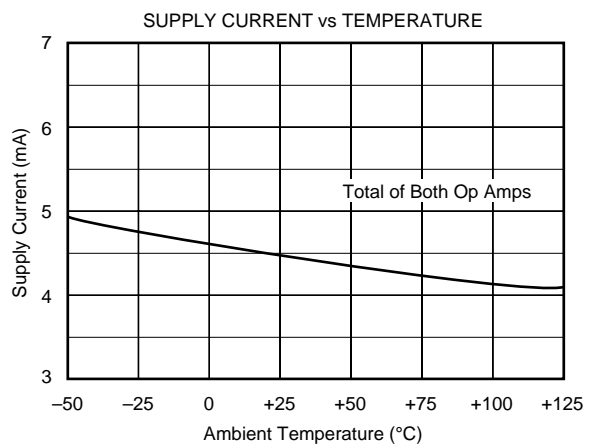
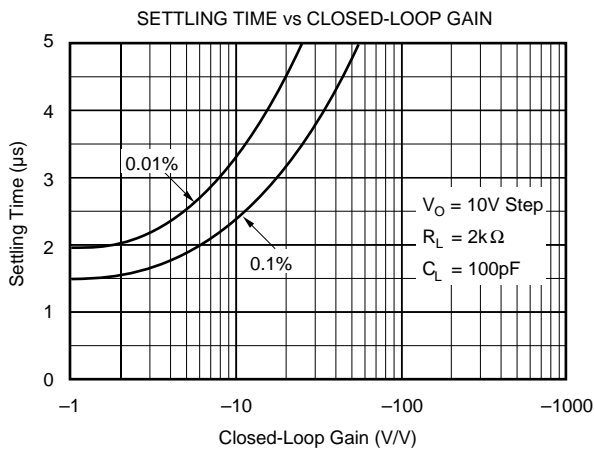
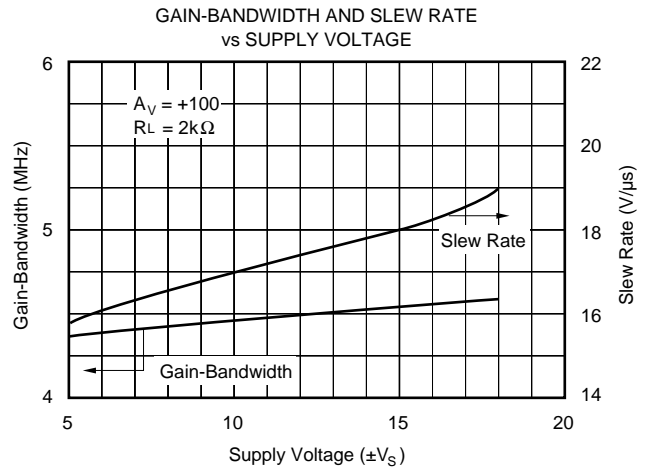
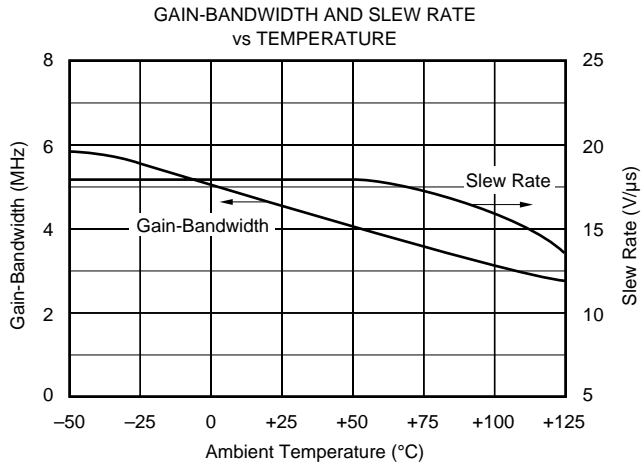
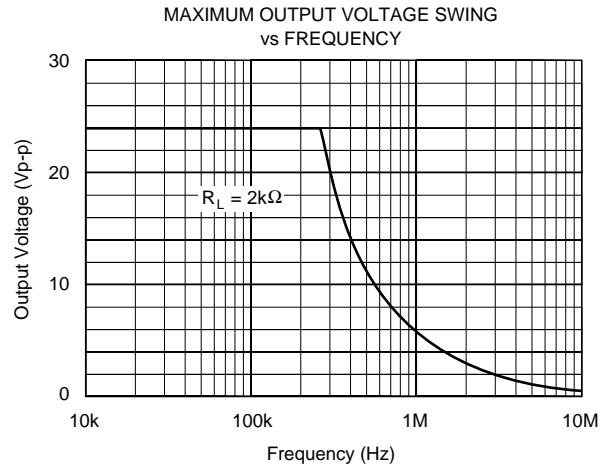
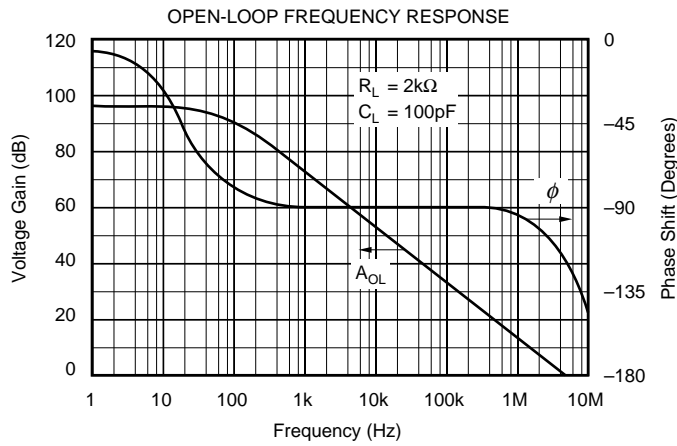

# TYPICAL CHARACTERISTICS (Cont.)

$T_A = +25^\circ\text{C}$ ,  $V_S = \pm 15\text{V}$  unless otherwise noted.

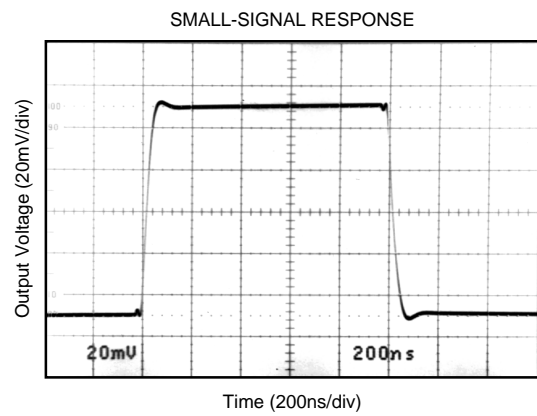
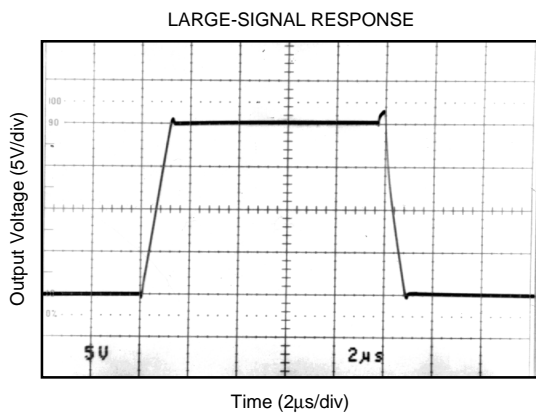
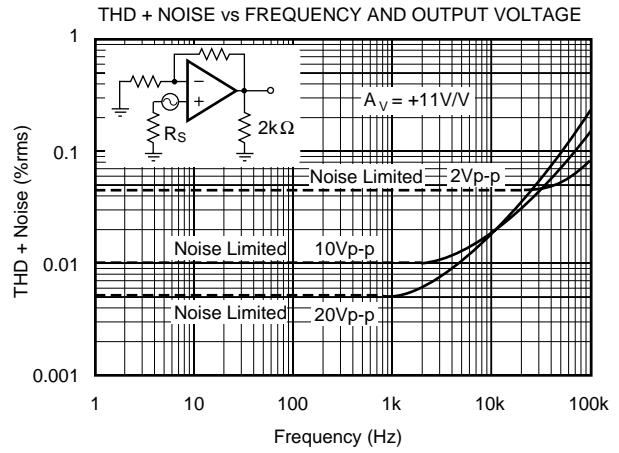
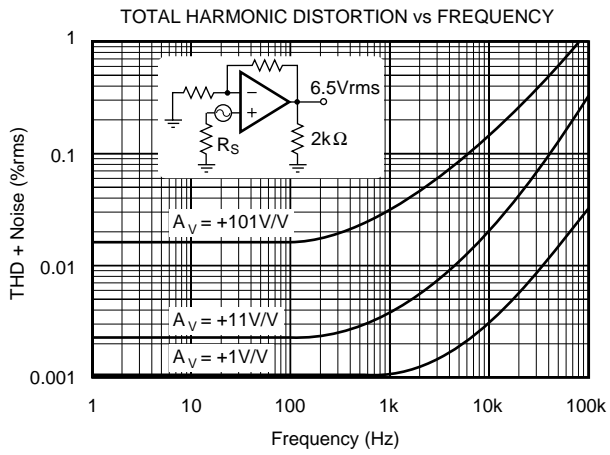
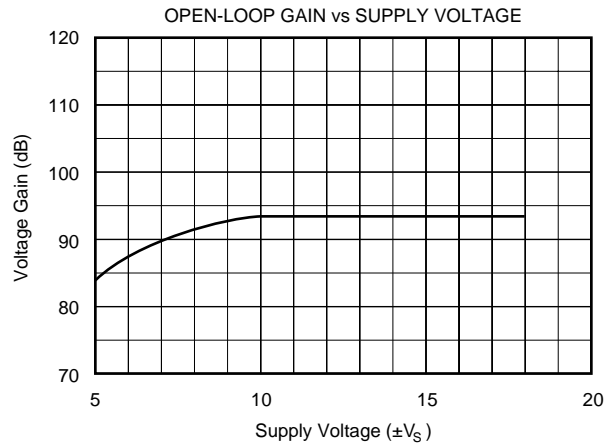
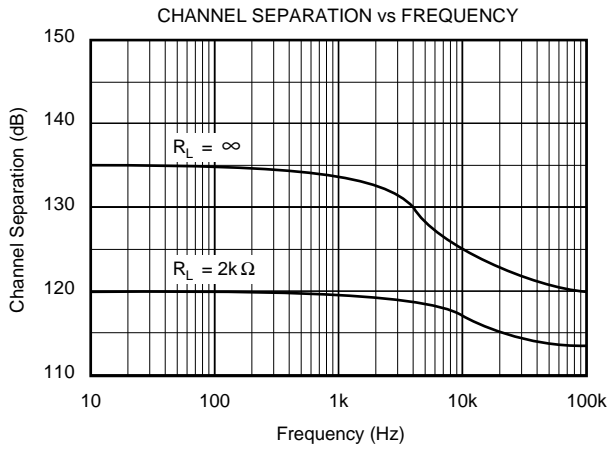

# APPLICATIONS INFORMATION AND CIRCUITS

The OPA2107 is unity-gain stable and has an excellent phase margin. This makes it easy to use in a wide variety of applications.

Power-supply connections should be bypassed with capacitors positioned close to the amplifier pins. In most cases, 0.1µF ceramic capacitors are adequate. Applications with larger load currents and fast transient signals may need up to 1µF tantalum bypass capacitors.

## INPUT BIAS CURRENT

The OPA2107 *Difet* input stages have very low input bias current—an order of magnitude lower than BIFET op amps. Circuit-board leakage paths can significantly degrade performance. This is especially evident with the SO-8 surface-mount package where pin-to-pin dimensions are particularly small. Residual soldering flux, dirt, and oils, which conduct leakage current, can be removed by proper cleaning. In most instances, a two-step cleaning process is adequate using a clean organic solvent rinse followed by deionized water. Each rinse should be followed by a 30-minute bake at 85°C. A circuit-board guard pattern effectively reduces errors due to circuit-board leakage (Figure 1). By encircling critical high-impedance nodes with a low-impedance connection at the same circuit potential, any leakage currents will flow harmlessly to the low-impedance node. Guard traces should be placed on all levels of a multiple-layer circuit board.

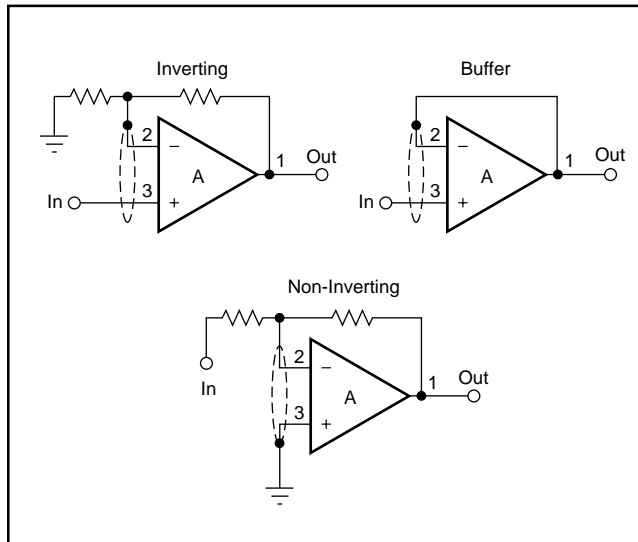

FIGURE 1. Connection of Input Guard.

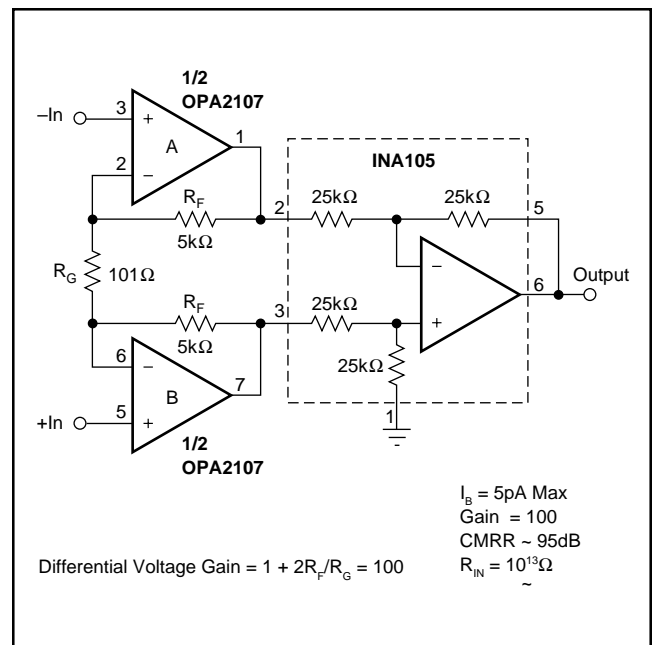

FIGURE 2. FET Input Instrumentation Amplifier.

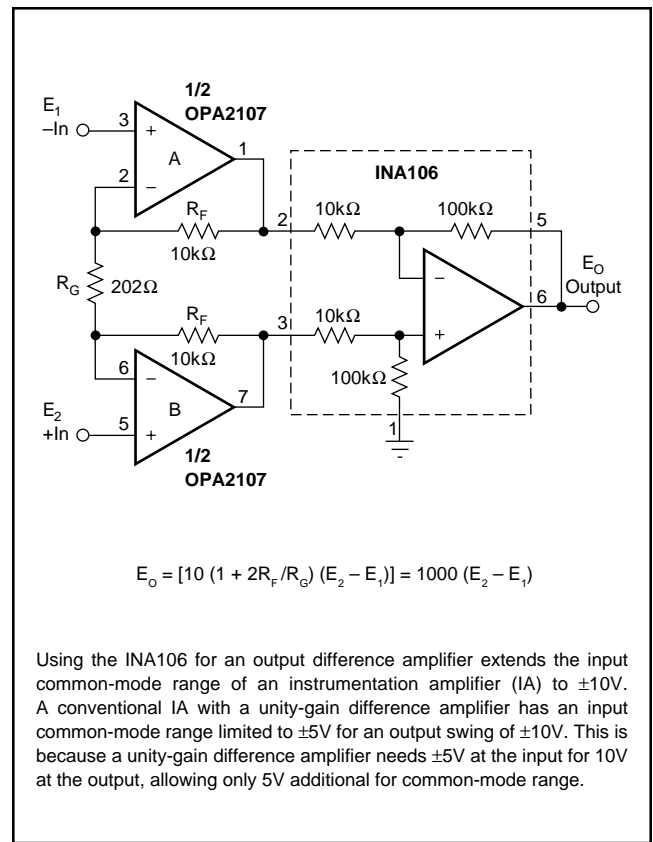

FIGURE 3. Precision Instrumentation Amplifier.

**PACKAGING INFORMATION**

Orderable Device	Status (1)	Package Type	Package Drawing	Pins	Package Qty	Eco Plan (2)	Lead finish/ Ball material (6)	MSL Peak Temp (3)	Op Temp (°C)	Device Marking (4/5)	Samples
OPA2107AU	NRND	SOIC	D	8	75	RoHS & Green	NIPDAU	Level-3-260C-168 HR	-25 to 80	OPA 2107AU	
OPA2107AU/2K5	ACTIVE	SOIC	D	8	2500	RoHS & Green	NIPDAU	Level-3-260C-168 HR	-25 to 85	OPA 2107AU	Samples
OPA2107AU/2K5E4	ACTIVE	SOIC	D	8	2500	TBD	Call TI	Call TI	-25 to 85		Samples

(1) The marketing status values are defined as follows:

**ACTIVE:** Product device recommended for new designs.

**LIFEBUY:** TI has announced that the device will be discontinued, and a lifetime-buy period is in effect.

**NRND:** Not recommended for new designs. Device is in production to support existing customers, but TI does not recommend using this part in a new design.

**PREVIEW:** Device has been announced but is not in production. Samples may or may not be available.

**OBSELETE:** TI has discontinued the production of the device.

(2) **RoHS:** TI defines "RoHS" to mean semiconductor products that are compliant with the current EU RoHS requirements for all 10 RoHS substances, including the requirement that RoHS substance do not exceed 0.1% by weight in homogeneous materials. Where designed to be soldered at high temperatures, "RoHS" products are suitable for use in specified lead-free processes. TI may reference these types of products as "Pb-Free".

**RoHS Exempt:** TI defines "RoHS Exempt" to mean products that contain lead but are compliant with EU RoHS pursuant to a specific EU RoHS exemption.

**Green:** TI defines "Green" to mean the content of Chlorine (Cl) and Bromine (Br) based flame retardants meet JS709B low halogen requirements of <=1000ppm threshold. Antimony trioxide based flame retardants must also meet the <=1000ppm threshold requirement.

(3) MSL, Peak Temp. - The Moisture Sensitivity Level rating according to the JEDEC industry standard classifications, and peak solder temperature.

(4) There may be additional marking, which relates to the logo, the lot trace code information, or the environmental category on the device.

(5) Multiple Device Markings will be inside parentheses. Only one Device Marking contained in parentheses and separated by a "-" will appear on a device. If a line is indented then it is a continuation of the previous line and the two combined represent the entire Device Marking for that device.

(6) Lead finish/Ball material - Orderable Devices may have multiple material finish options. Finish options are separated by a vertical ruled line. Lead finish/Ball material values may wrap to two lines if the finish value exceeds the maximum column width.

**Important Information and Disclaimer:**The information provided on this page represents TI's knowledge and belief as of the date that it is provided. TI bases its knowledge and belief on information provided by third parties, and makes no representation or warranty as to the accuracy of such information. Efforts are underway to better integrate information from third parties. TI has taken and continues to take reasonable steps to provide representative and accurate information but may not have conducted destructive testing or chemical analysis on incoming materials and chemicals. TI and TI suppliers consider certain information to be proprietary, and thus CAS numbers and other limited information may not be available for release.



In no event shall TI's liability arising out of such information exceed the total purchase price of the TI part(s) at issue in this document sold by TI to Customer on an annual basis.

**TAPE AND REEL INFORMATION**

**QUADRANT ASSIGNMENTS FOR PIN 1 ORIENTATION IN TAPE**

\*All dimensions are nominal

Device	Package Type	Package Drawing	Pins	SPQ	Reel Diameter (mm)	Reel Width W1 (mm)	A0 (mm)	B0 (mm)	K0 (mm)	P1 (mm)	W (mm)	Pin1 Quadrant
OPA2107AU/2K5	SOIC	D	8	2500	330.0	12.4	6.4	5.2	2.1	8.0	12.0	Q1

**TAPE AND REEL BOX DIMENSIONS**

\*All dimensions are nominal

Device	Package Type	Package Drawing	Pins	SPQ	Length (mm)	Width (mm)	Height (mm)
OPA2107AU/2K5	SOIC	D	8	2500	356.0	356.0	35.0

**TUBE**

\*All dimensions are nominal

Device	Package Name	Package Type	Pins	SPQ	L (mm)	W (mm)	T (μm)	B (mm)
OPA2107AU	D	SOIC	8	75	506.6	8	3940	4.32



D0008A

# PACKAGE OUTLINE

SOIC - 1.75 mm max height

SMALL OUTLINE INTEGRATED CIRCUIT



4214825/C 02/2019

### NOTES:

- Linear dimensions are in inches [millimeters]. Dimensions in parenthesis are for reference only. Controlling dimensions are in inches. Dimensioning and tolerancing per ASME Y14.5M.
- This drawing is subject to change without notice.
- This dimension does not include mold flash, protrusions, or gate burrs. Mold flash, protrusions, or gate burrs shall not exceed  $.006$  [0.15] per side.
- This dimension does not include interlead flash.
- Reference JEDEC registration MS-012, variation AA.

# EXAMPLE BOARD LAYOUT

D0008A

SOIC - 1.75 mm max height

SMALL OUTLINE INTEGRATED CIRCUIT



LAND PATTERN EXAMPLE  
EXPOSED METAL SHOWN  
SCALE:8X



SOLDER MASK DETAILS

4214825/C 02/2019

NOTES: (continued)

6. Publication IPC-7351 may have alternate designs.

7. Solder mask tolerances between and around signal pads can vary based on board fabrication site.

# EXAMPLE STENCIL DESIGN

D0008A

SOIC - 1.75 mm max height

SMALL OUTLINE INTEGRATED CIRCUIT



SOLDER PASTE EXAMPLE  
BASED ON .005 INCH [0.125 MM] THICK STENCIL  
SCALE:8X

4214825/C 02/2019

NOTES: (continued)

8. Laser cutting apertures with trapezoidal walls and rounded corners may offer better paste release. IPC-7525 may have alternate design recommendations.
9. Board assembly site may have different recommendations for stencil design.

## IMPORTANT NOTICE AND DISCLAIMER

TI PROVIDES TECHNICAL AND RELIABILITY DATA (INCLUDING DATA SHEETS), DESIGN RESOURCES (INCLUDING REFERENCE DESIGNS), APPLICATION OR OTHER DESIGN ADVICE, WEB TOOLS, SAFETY INFORMATION, AND OTHER RESOURCES "AS IS" AND WITH ALL FAULTS, AND DISCLAIMS ALL WARRANTIES, EXPRESS AND IMPLIED, INCLUDING WITHOUT LIMITATION ANY IMPLIED WARRANTIES OF MERCHANTABILITY, FITNESS FOR A PARTICULAR PURPOSE OR NON-INFRINGEMENT OF THIRD PARTY INTELLECTUAL PROPERTY RIGHTS.

These resources are intended for skilled developers designing with TI products. You are solely responsible for (1) selecting the appropriate TI products for your application, (2) designing, validating and testing your application, and (3) ensuring your application meets applicable standards, and any other safety, security, regulatory or other requirements.

These resources are subject to change without notice. TI grants you permission to use these resources only for development of an application that uses the TI products described in the resource. Other reproduction and display of these resources is prohibited. No license is granted to any other TI intellectual property right or to any third party intellectual property right. TI disclaims responsibility for, and you will fully indemnify TI and its representatives against, any claims, damages, costs, losses, and liabilities arising out of your use of these resources.

TI's products are provided subject to [TI's Terms of Sale](#) or other applicable terms available either on [ti.com](http://ti.com) or provided in conjunction with such TI products. TI's provision of these resources does not expand or otherwise alter TI's applicable warranties or warranty disclaimers for TI products.

TI objects to and rejects any additional or different terms you may have proposed.

Mailing Address: Texas Instruments, Post Office Box 655303, Dallas, Texas 75265  
Copyright © 2022, Texas Instruments Incorporated