

## LM759/LM77000 Power Operational Amplifiers

### General Description

The LM759 and LM77000 are high performance operational amplifiers that feature high output current capability. The LM759 is capable of providing 325 mA and the LM77000 providing 250 mA. Both amplifiers feature small signal characteristics that are better than the LM741. The amplifiers are designed to operate from a single or dual power supply with an input common mode range that includes the negative supply. The high gain and high output power provide superior performance. Internal current limiting, thermal shutdown, and safe area compensation are employed making the LM759 and LM77000 essentially indestructible.

### Features

- Output current
  - LM759—325 mA minimum
  - LM77000—250 mA minimum
- Internal short circuit current limiting
- Internal thermal overload protection
- Internal output transistors safe-area protection
- Input common mode voltage range includes ground or negative supply

### Applications

- Voltage regulators
- Audio amplifiers
- Servo amplifiers
- Power drivers

### Connection Diagrams and Ordering Information

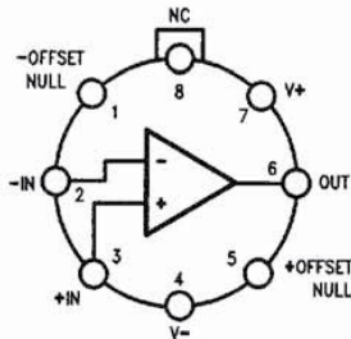

TL/H/10075-1

Lead 4 connected to case.

Top View

Order Number LM759MH, LM759CH or LM759H/883  
See NS Package Number H08C

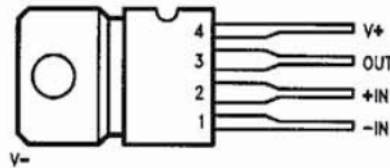

TL/H/10075-2

Top View

Order Number LM759CP or LM77000CP  
See NS Package Number P04A

1

## Absolute Maximum Ratings

If Military/Aerospace specified devices are required, please contact the National Semiconductor Sales Office/Distributors for availability and specifications.

Storage Temperature Range		
Metal Can		-65°C to +175°C
Plastic Package		-65°C to +150°C
Operating Junction Temperature Range		
Military (LM759M)		-55°C to +150°C
Commercial (LM759C, LM77000C)		0°C to +125°C
Lead Temperature		
Metal Can (soldering, 60 sec)		300°C
Plastic Package (soldering, 10 sec)		265°C

Internal Power Dissipation (Note 1)	Internally Limited
Supply Voltage	±18V
Differential Input Voltage	30V
Input Voltage (note 2)	±15V

## LM759

**Electrical Characteristics**  $T_J = 25^\circ\text{C}$ ,  $V_{CC} = \pm 15\text{V}$ , unless otherwise specified

Symbol	Parameter	Conditions	Min	Typ	Max	Units	
$V_{IO}$	Input Offset Voltage	$R_S \leq 10\text{ k}\Omega$		1.0	3.0	mV	
$I_{IO}$	Input Offset Current			5.0	30	nA	
$I_{IB}$	Input Bias Current			50	150	nA	
$Z_I$	Input Impedance		0.25	1.5		M $\Omega$	
$I_{CC}$	Supply Current			12	18	mA	
$V_{IR}$	Input Voltage Range		$V^+ - 2\text{V to } V^-$	$V^+ - 2\text{V to } V^-$		V	
$I_{OS}$	Output Short Circuit Current	$ V_{CC} - V_O  = 30\text{V}$		±200		mA	
$I_{O\text{ PEAK}}$	Peak Output Current	$3.0\text{V} \leq  V_{CC} - V_O  \leq 10\text{V}$	±325	±500		mA	
$A_{VS}$	Large Signal Voltage Gain	$R_L \geq 50\Omega$ , $V_O = \pm 10\text{V}$	50	200		V/mV	
TR	Transient Response	$R_L = 50\Omega$ , $A_V = 1.0$	Rise Time		300		ns
			Overshoot		5.0		%
SR	Slew Rate	$R_L = 50\Omega$ , $A_V = 1.0$		0.6		V/ $\mu\text{s}$	
BW	Bandwidth	$A_V = 1.0$		1.0		MHz	

The following specifications apply for  $-55^\circ\text{C} \leq T_J \leq +150^\circ\text{C}$

$V_{IO}$	Input Offset Voltage	$R_S \leq 10\text{ k}\Omega$			4.5	mV
$I_{IO}$	Input Offset Current				60	nA
$I_{IB}$	Input Bias Current				300	nA
CMRR	Common Mode Rejection Ratio	$R_S \leq 10\text{ k}\Omega$	80	100		dB
PSRR	Power Supply Rejection Ratio	$R_S \leq 10\text{ k}\Omega$	80	100		dB
$A_{VS}$	Large Signal Voltage Gain	$R_L \geq 50\Omega$ , $V_O = \pm 10\text{V}$	25	200		V/mV
$V_{OP}$	Output Voltage Swing	$R_L = 50\Omega$	±10	±12.5		V

**LM759C****Electrical Characteristics**  $T_J = 25^\circ\text{C}$ ,  $V_{CC} = \pm 15\text{V}$ , unless otherwise specified

Symbol	Parameter	Conditions	Min	Typ	Max	Units
$V_{IO}$	Input Offset Voltage	$R_S \leq 10\text{ k}\Omega$		1.0	6.0	mV
$I_{IO}$	Input Offset Current			5.0	50	nA
$I_{IB}$	Input Bias Current			50	250	nA
$Z_I$	Input Impedance		0.25	1.5		M $\Omega$
$I_{CC}$	Supply Current			12	18	mA
$V_{IR}$	Input Voltage Range		$V^+ - 2\text{V to } V^-$	$V^+ - 2\text{V to } V^-$		V
$I_{OS}$	Output Short Circuit Current	$ V_{CC} - V_O  = 30\text{V}$		$\pm 200$		mA
$I_{O\text{ PEAK}}$	Peak Output Current	$3.0\text{V} \leq  V_{CC} - V_O  \leq 10\text{V}$	$\pm 325$	$\pm 500$		mA
$A_{VS}$	Large Signal Voltage Gain	$R_L \geq 50\Omega$ , $V_O = \pm 10\text{V}$	25	200		V/mV
TR	Transient Response	Rise Time	$R_L = 50\Omega$ , $A_V = 1.0$	300		ns
		Overshoot		10		%
SR	Slew Rate	$R_L = 50\Omega$ , $A_V = 1.0$		0.5		V/ $\mu\text{s}$
BW	Bandwidth	$A_V = 1.0$		1.0		MHz

The following specifications apply for  $0^\circ \leq T_J \leq +125^\circ\text{C}$

$V_{IO}$	Input Offset Voltage	$R_S \leq 10\text{ k}\Omega$			7.5	mV
$I_{IO}$	Input Offset Current				100	nA
$I_{IB}$	Input Bias Current				400	nA
CMRR	Common Mode Rejection Ratio	$R_S \leq 10\text{ k}\Omega$	70	100		dB
PSRR	Power Supply Rejection Ratio	$R_S \leq 10\text{ k}\Omega$	80	100		dB
$A_{VS}$	Large Signal Voltage Gain	$R_L \geq 50\Omega$ , $V_O = \pm 10\text{V}$	25	200		V/mV
$V_{OP}$	Output Voltage Swing	$R_L = 50\Omega$	$\pm 10$	$\pm 12.5$		V

**LM77000****Electrical Characteristics**  $T_J = 25^\circ\text{C}$ ,  $V_{CC} = \pm 15\text{V}$ , unless otherwise specified

Symbol	Parameter	Conditions	Min	Typ	Max	Units	
$V_{IO}$	Input Offset Voltage	$R_S \leq 10\text{ k}\Omega$		1.0	8.0	mV	
$I_{IO}$	Input Offset Current			5.0	50	nA	
$I_{IB}$	Input Bias Current			50	250	nA	
$Z_I$	Input Impedance		0.25	1.5		M $\Omega$	
$I_{CC}$	Supply Current			12	18	mA	
$V_{IR}$	Input Voltage Range		+13 to $V^-$	+13 to $V^-$		V	
$I_{OS}$	Output Short Circuit Current	$ V_{CC} - V_O  = 30\text{V}$		$\pm 200$		mA	
$I_{O\text{ PEAK}}$	Peak Output Current	$3.0\text{V} \leq  V_{CC} - V_O  \leq 10\text{V}$	$\pm 250$	$\pm 400$		mA	
$A_{VS}$	Large Signal Voltage Gain	$R_L \geq 50\Omega$ , $V_O = \pm 10\text{V}$	25	200		V/mV	
TR	Transient Response	Rise Time	$R_L = 50\Omega$ , $A_V = 1.0$		300		ns
		Overshoot			10		%
SR	Slew Rate	$R_L = 50\Omega$ , $A_V = 1.0$		0.5		V/ $\mu\text{s}$	
BW	Bandwidth	$A_V = 1.0$		1.0		MHz	

The following specifications apply for  $0^\circ \leq T_J \leq +125^\circ\text{C}$

$V_{IO}$	Input Offset Voltage	$R_S \leq 10\text{ k}\Omega$			10	mV
$I_{IO}$	Input Offset Current				100	nA
$I_{IB}$	Input Bias Current				400	nA
CMR	Common Mode Rejection	$R_S \leq 10\text{ k}\Omega$	70	100		dB
PSRR	Power Supply Rejection Ratio	$R_S \leq 10\text{ k}\Omega$	80	100		dB
$A_{VS}$	Large Signal Voltage Gain	$R_L \geq 50\Omega$ , $V_O = \pm 10\text{V}$	25	200		V/mV
$V_{OP}$	Output Voltage Swing	$R_L = 50\Omega$	$\pm 10$	$\pm 12.5$		V

**Note 1:** Although the internal power dissipation is limited, the junction temperature must be kept below the maximum specified temperature in order to meet data sheet specifications. To calculate the maximum junction temperature or heat sink required, use the thermal resistance values which follow the Equivalent Circuit Schematic.

**Note 2:** For a supply voltage less than 30V between  $V^+$  and  $V^-$ , the absolute maximum input voltage is equal to the supply voltage.

**Note 3:** For military electrical specifications RETS759X are available for LM759H.

# Equivalent Circuit

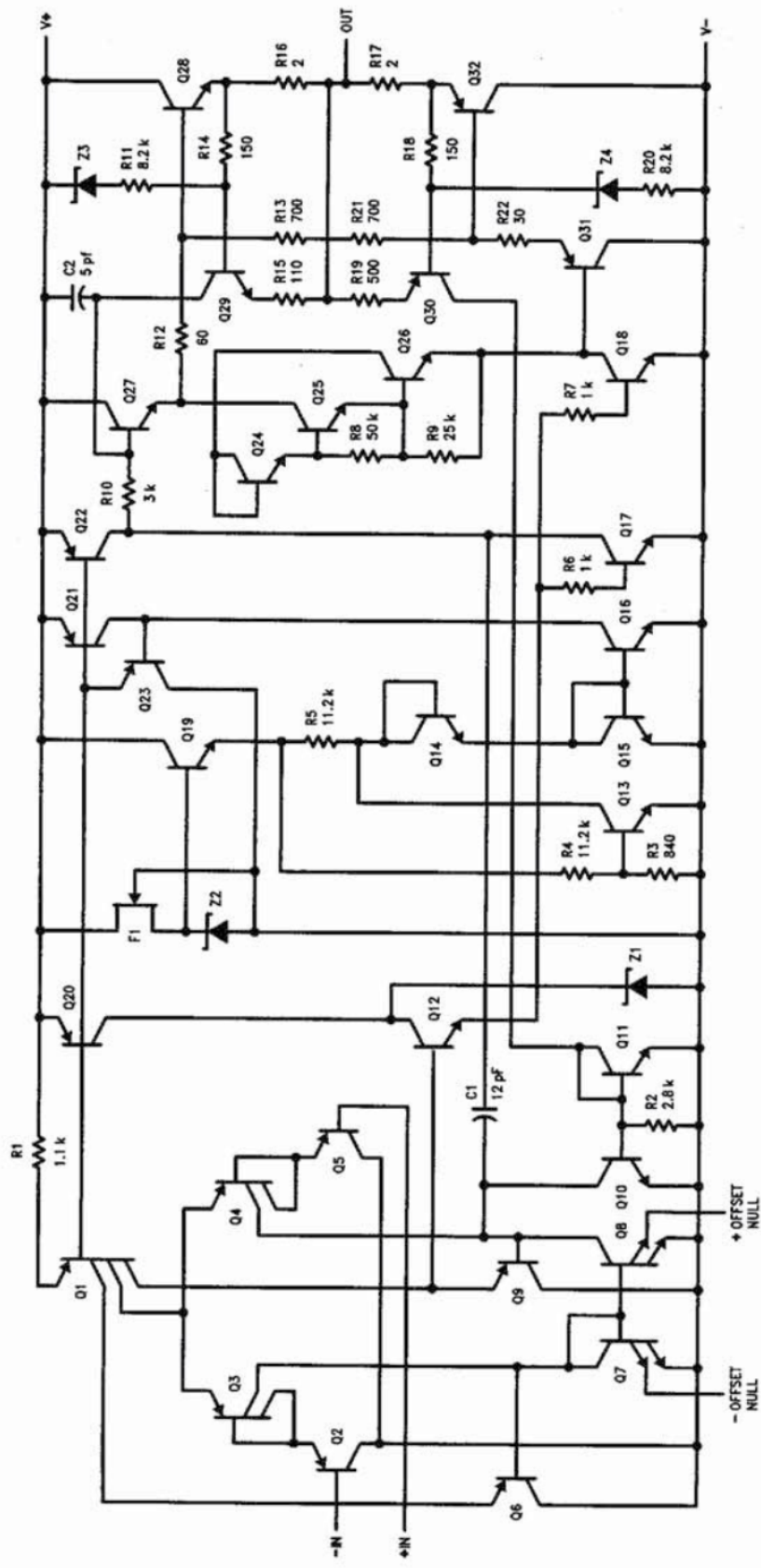

TL/H/10075-3

Note: All resistor values in ohms.

LM759/LM77000

1

Package	Typ $\theta_{JC}$ °C/W	Max $\theta_{JC}$ °C/W	Typ $\theta_{JA}$ °C/W	Max $\theta_{JA}$ °C/W
Plastic Package (P)	8.0	12	75	80
Metal Can (H)	30	40	120	150

$$P_{D \text{ Max}} = \frac{T_{J \text{ Max}} - T_A}{\theta_{JC} + \theta_{CA}} \text{ or}$$

$$= \frac{T_{J \text{ Max}} - T_A}{\theta_{JA}} \text{ (without a heat sink)}$$

$$\theta_{CA} = \theta_{CS} + \theta_{SA}$$

Solving  $T_J$ :

$$T_J = T_A + P_D (\theta_{JC} + \theta_{CA}) \text{ or}$$

$$= T_A + P_D \theta_{JA} \text{ (without a heat sink)}$$

Where:

- $T_J$  = Junction Temperature
- $T_A$  = Ambient Temperature
- $P_D$  = Power Dissipation
- $\theta_{JA}$  = Junction to ambient thermal resistance
- $\theta_{JC}$  = Junction to case thermal resistance
- $\theta_{CA}$  = Case to ambient thermal resistance
- $\theta_{CS}$  = Case to heat sink thermal resistance
- $\theta_{SA}$  = Heat sink to ambient thermal resistance

## Mounting Hints

### Metal Can Package (LM759CH/LM759MH)

The LM759 in the 8-Lead TO-99 metal can package must be used with a heat sink. With  $\pm 15V$  power supplies, the LM759 can dissipate up to 540 mW in its quiescent (no load) state. This would result in a 100°C rise in chip temperature to 125°C (assuming a 25°C ambient temperature). In order to avoid this problem, it is advisable to use either a slip on or stud mount heat sink with this package. If a stud mount heat sink is used, it may be necessary to use insulating washers between the stud and the chassis because the case of the LM759 is internally connected to the negative power supply terminal.

### Plastic Package (LM759CP/LM77000CP)

The LM759CP and LM77000CP are designed to be attached by the tab to a heat sink. This heat sink can be either one of the many heat sinks which are commercially available, a piece of metal such as the equipment chassis, or a suitable amount of copper foil as on a double sided PC board. The important thing to remember is that the negative power supply connection to the op amp must be made through the tab. Furthermore, adequate heat sinking must be provided to keep the chip temperature below 125°C under worst case load and ambient temperature conditions.

# Typical Performance Characteristics

**Frequency Response for Various Closed Loop Gains**

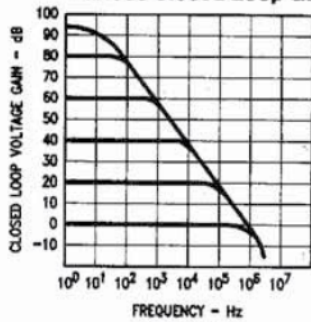

**Open Loop vs Frequency Response**

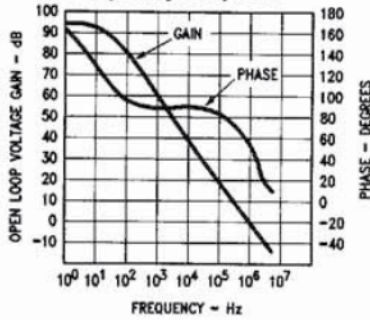

**Output Voltage vs Frequency**

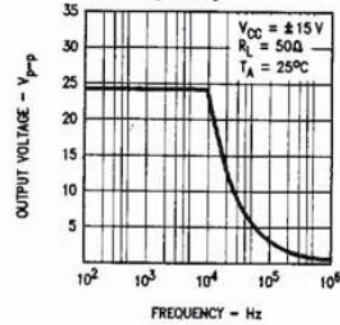

**Output Voltage vs Load Resistance**

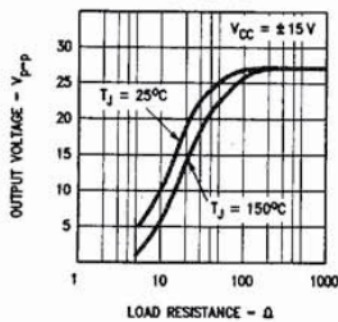

**Voltage Follower Large Signal Pulse Response**

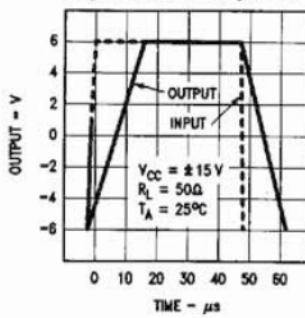

**Voltage Follower Transient Response**

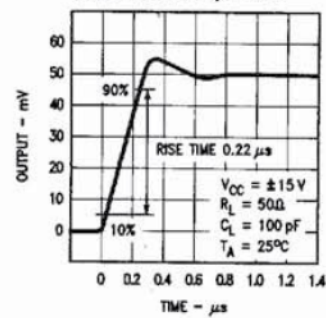

**Total Harmonic Distortion vs Frequency**

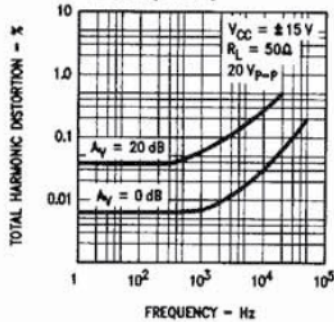

**Total Harmonic Distortion vs Power Output**

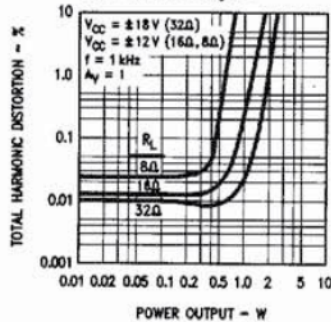

**Input Noise Voltage vs Frequency**

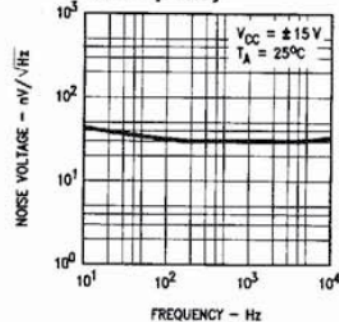

**Noise Current vs Frequency**

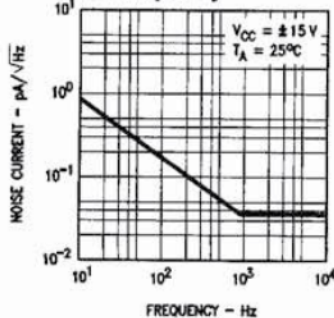

**Short Circuit Current vs Junction Temperature**

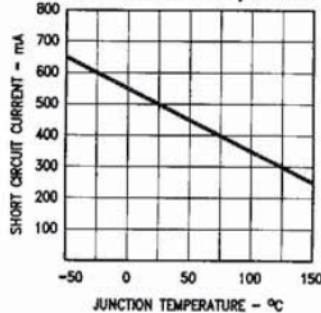

**Peak Output Current vs Output Voltage**

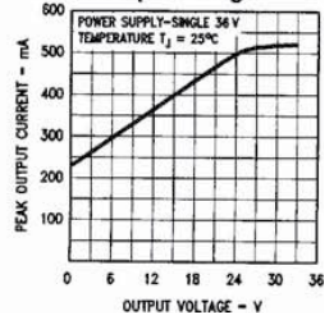

TL/H/10075-4

1

## Applications

Offset Null Circuit

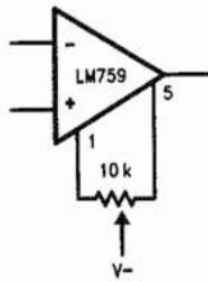

TL/H/10075-5

Paralleling LM759 Power Op Amps

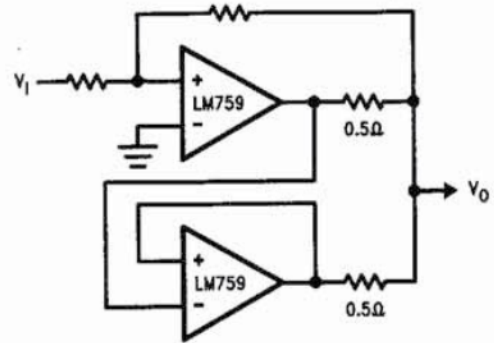

TL/H/10075-6

## Audio Applications

Low Cost Phono Amplifier

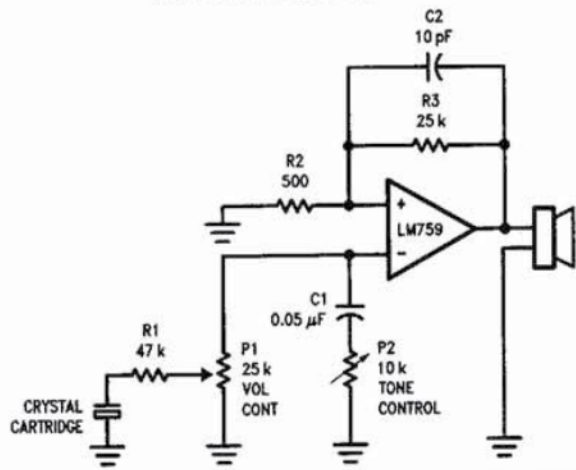

TL/H/10075-7

Speaker Impedance (Ohms)	Output Power (Watts)	Min Supply (Volts)	V <sub>Op-P</sub> (Volts)
4	0.18	9	2.4
8	0.36	12	4.8
16	0.72	15	9.6
32	1.44	25	19.2



Applications (Continued)

Bi-Directional Intercom System Using the LM759 Power Op Amp

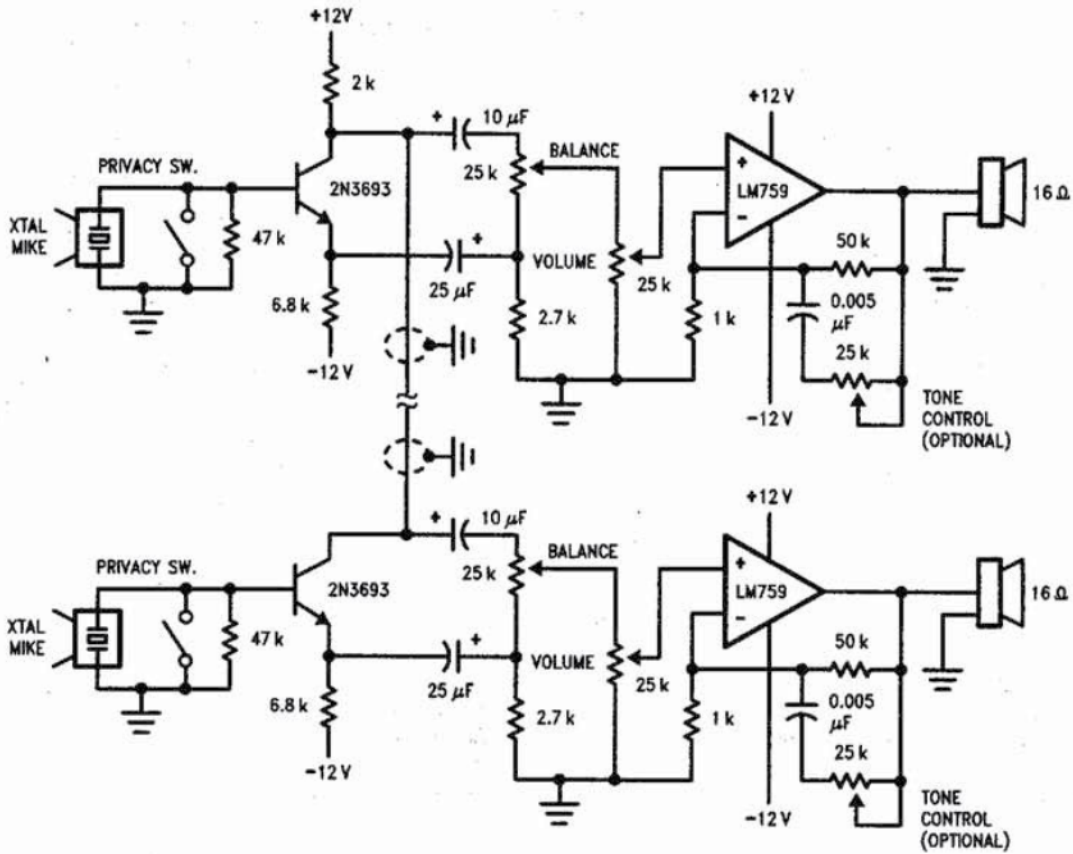

TL/H/10075-9

Features:

- Circuit Simplicity
  - 1 Watt of Audio Output
  - Duplex operation with only one two-wire cable as interconnect.
- Note 1:** All resistor values in ohms.

**Applications** (Continued)

**High Slew Rate Power Op Amp/Audio Amp**

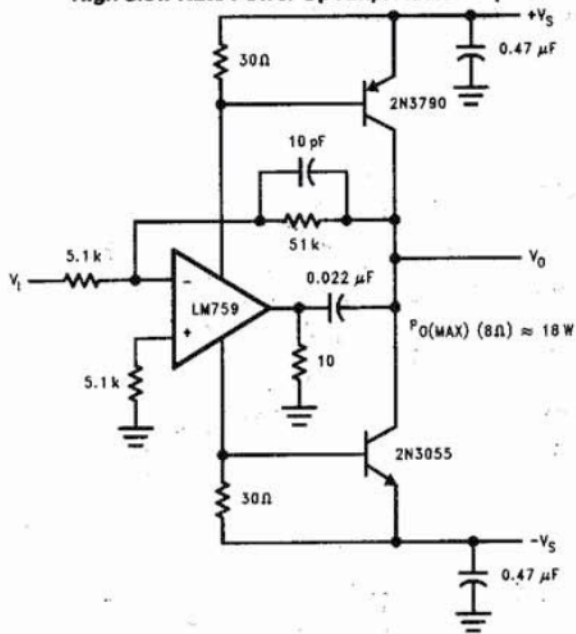

TL/H/10075-10

**Features:**

- High Slew Rate 9 V/ $\mu$ s
- High 3 dB Power Bandwidth 85 kHz
- 18 Watts Output Power into an 8 $\Omega$  load.
- Low Distortion—0.2%, 10 V<sub>rms</sub>, 1 kHz into 8 $\Omega$
- Design Consideration
- $A_V \geq 10$

**Servo Applications**

**AG Servo Amplifier—Bridge Type**

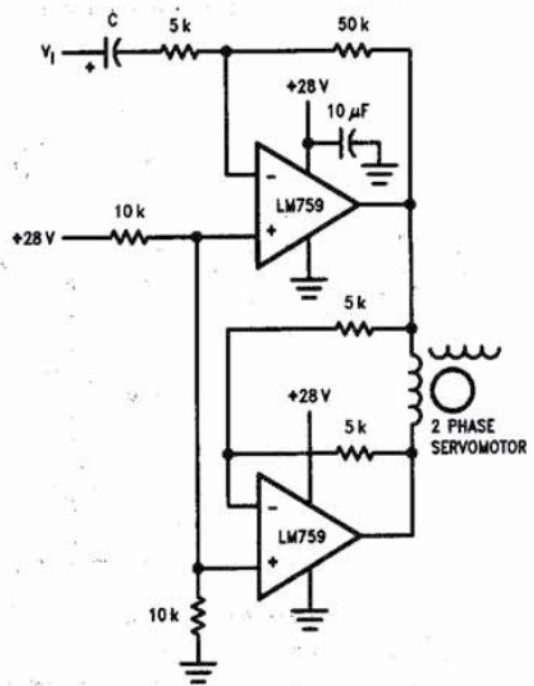

TL/H/10075-11

**Features:**

- Gain of 10
- Use of LM759 Means Simple Inexpensive Circuit
- Design Considerations:**
- 325 mA Max Output Current

**DC Servo Amplifier**

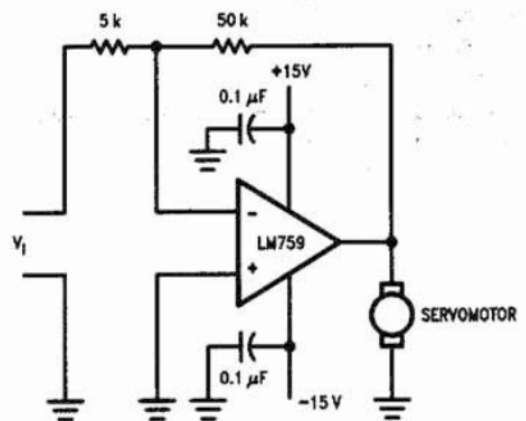

TL/H/10075-12

**Features:**

- Circuit Simplicity
- One Chip Means Excellent Reliability
- Design Considerations
- $I_O \leq 325$  mA
- Note 1:** All resistor values in ohms.

# Regulator Applications

### Adjustable Dual Tracking Regulator

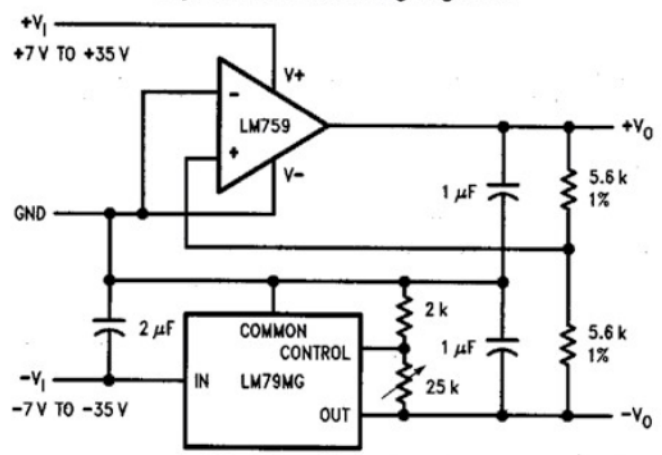

TL/H/10075-13

**Features:**

- Wide Output Voltage Range ( $\pm 2.2V$  to  $\pm 30V$ )
- Excellent Load Regulation  $\Delta V_O < \pm 5 \text{ mV}$  for  $\Delta I_O = \pm 0.2 \text{ A}$
- Excellent Line Regulation  $\Delta V_O < \pm 2 \text{ mV}$  for  $\Delta V_I = 10V$

**Note 1:** All resistor values in ohms.

### 10 Amp — 12 Volt Regulator

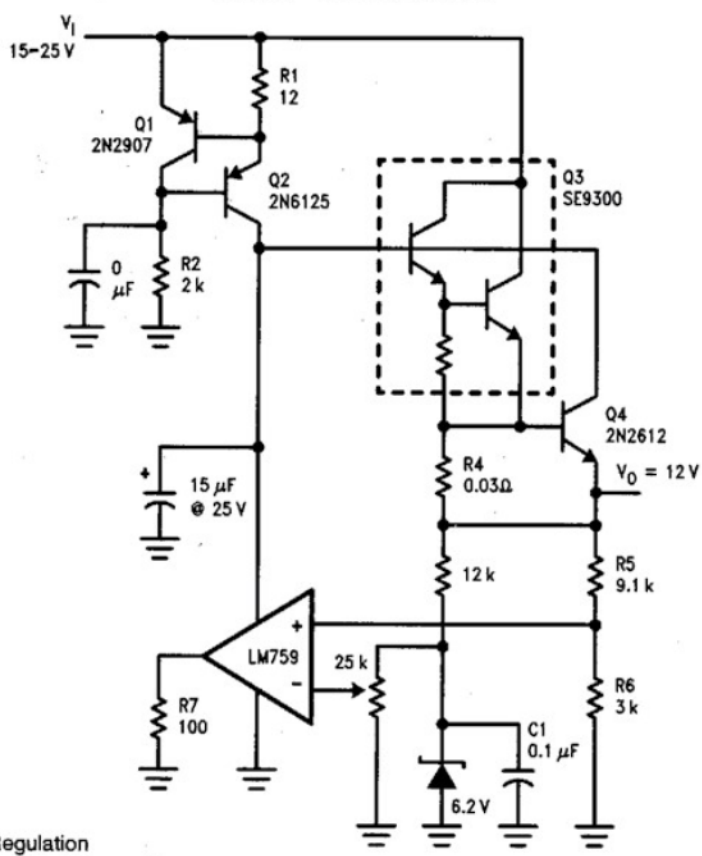

TL/H/10075-14

**Features:**

- Excellent Load and Line Regulation
- Excellent Temperature Coefficient-Depends Largely on Tempco of the Reference Zener

**Note 1:** All resistor values in ohms.

1

**Physical Dimensions** inches (millimeters)

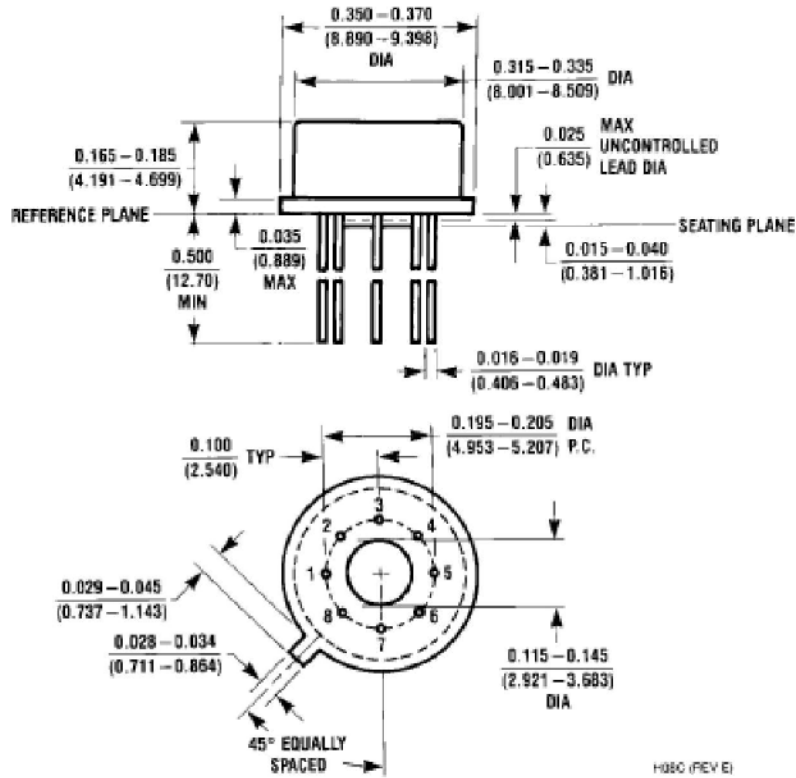

H08C (REV E)

**8-Lead Metal Package**  
**Order Number LM759MH, LM759CH or LM759H/883**  
**NS Package Number H08C**

## Physical Dimensions inches (millimeters) (Continued)

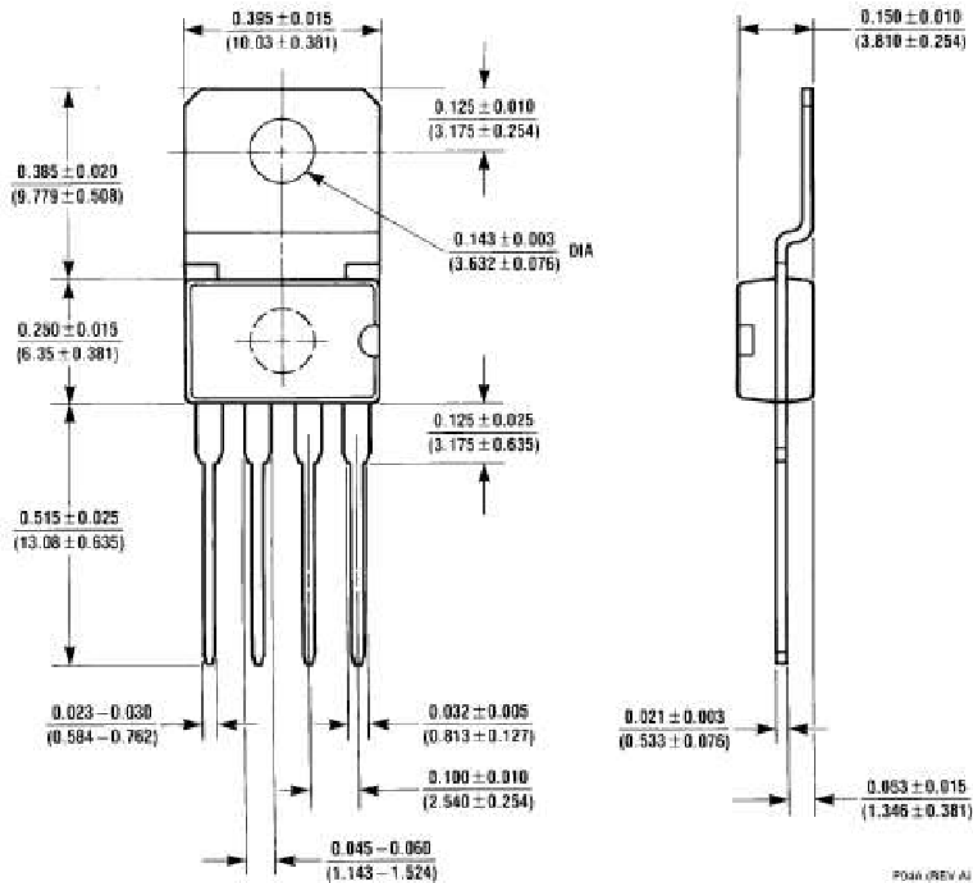

Order Number LM759CP or LM77000CP  
NS Package Number P04A

P04A (REV A)

### LIFE SUPPORT POLICY

NATIONAL'S PRODUCTS ARE NOT AUTHORIZED FOR USE AS CRITICAL COMPONENTS IN LIFE SUPPORT DEVICES OR SYSTEMS WITHOUT THE EXPRESS WRITTEN APPROVAL OF THE PRESIDENT OF NATIONAL SEMICONDUCTOR CORPORATION. As used herein:

1. Life support devices or systems are devices or systems which, (a) are intended for surgical implant into the body, or (b) support or sustain life, and whose failure to perform, when properly used in accordance with instructions for use provided in the labeling, can be reasonably expected to result in a significant injury to the user.
2. A critical component is any component of a life support device or system whose failure to perform can be reasonably expected to cause the failure of the life support device or system, or to affect its safety or effectiveness.



National Semiconductor Corporation  
1111 West Bardin Road  
Arlington, TX 76017  
Tel: 1(800) 272-9959  
Fax: 1(800) 737-7018

National Semiconductor Europe  
Fax: (+49) 0-180-530 85 86  
Email: onjw@trm2.nsc.com  
Deutsch Tel: (+49) 0-180-530 85 85  
English Tel: (+49) 0-180-532 78 32  
Français Tel: (+49) 0-180-532 93 58  
Italiano Tel: (+49) 0-180-534 16 80

National Semiconductor Hong Kong Ltd.  
13th Floor, Straight Block,  
Ocean Centre, 5 Canton Rd.,  
Tsimshatsui, Kowloon  
Hong Kong  
Tel: (852) 2737-1800  
Fax: (852) 2736-9960

National Semiconductor Japan Ltd.  
Tel: 81-043-299-2309  
Fax: 81-043-299-2408