



ISO113

Low-Cost, High-Voltage, Internally Powered OUTPUT ISOLATION AMPLIFIER

FEATURES

- SELF-CONTAINED ISOLATED SIGNAL AND OUTPUT POWER
- SMALL PACKAGE SIZE: Double-Wide (0.6") Sidebrazed DIP
- CONTINUOUS AC BARRIER RATING: 1500Vrms
- WIDE BANDWIDTH: 20kHz Small Signal, 20kHz Full Power
- BUILT-IN ISOLATED OUTPUT POWER: $\pm 10V$ to $\pm 18V$ Input, $\pm 50mA$ Output
- MULTICHANNEL SYNCHRONIZATION CAPABILITY
- BOARD AREA ONLY 0.72in.² (4.6cm²)

APPLICATIONS

- 4mA TO 20mA V/I CONVERTERS
- MOTOR AND VALVE CONTROLLERS
- ISOLATED RECORDER OUTPUTS
- MEDICAL INSTRUMENTATION OUTPUTS
- GAS ANALYZERS

DESCRIPTION

The ISO113 output isolation amplifier provides both signal and output power across an isolation barrier in a small double-wide DIP package. The ceramic non-hermetic hybrid package with side-brazed pins contains a transformer-coupled DC/DC converter and a capacitor-coupled signal channel.

Extra power is available on the isolated output side for driving external loads. The converter is protected from shorts to ground with an internal current limit, and the soft-start feature limits the initial currents from the power source. Multiple-channel synchronization can be accomplished by applying a TTL clock signal to paralleled Sync pins. The Enable control is used to turn off transformer drive while keeping the signal channel modulator active. This feature provides a convenient way to reduce quiescent current for low power applications.

The wide barrier pin spacing and internal insulation allow for the generous 1500Vrms continuous rating. Reliability is assured by 100% barrier breakdown testing that conforms to UL1244 test methods. Low barrier capacitance minimizes AC leakage currents.

These specifications and built-in features make the ISO113 easy to use, and provides for compact PC board layout.

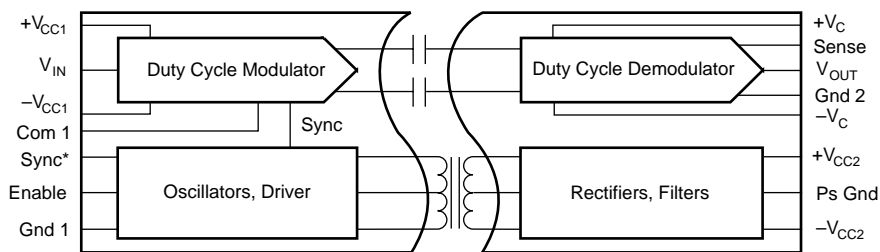

*Ground if not used

International Airport Industrial Park • Mailing Address: PO Box 11400, Tucson, AZ 85734 • Street Address: 6730 S. Tucson Blvd., Tucson, AZ 85706 • Tel: (520) 746-1111
Twx: 910-952-1111 • Internet: <http://www.burr-brown.com/> • Cable: BBRCORP • Telex: 066-6491 • FAX: (520) 889-1510 • Immediate Product Info: (800) 548-6132

SPECIFICATIONS

ELECTRICAL

At $T_A = +25^\circ\text{C}$ and $V_{CC1} = \pm 15\text{V}$, $\pm 15\text{mA}$ output, current unless otherwise noted.

PARAMETER	CONDITIONS	ISO113			ISO113B			UNITS
		MIN	TYP	MAX	MIN	TYP	MAX	
ISOLATION								
Rated Continuous Voltage AC, 60Hz	T_{MIN} to T_{MAX}	1500			*			Vrms
DC	T_{MIN} to T_{MAX}	2121			*			VDC
Test Breakdown, 100% AC, 60Hz	10s	5657			*			Vpk
Isolation-Mode Rejection	1500Vrms, 60Hz 2121VDC		130			*		dB
Barrier Impedance			160			*		dB
Leakage Current	240Vrms, 60Hz		$10^{12} \parallel 9$	2		*	*	$\Omega \parallel \text{pF}$ μA
GAIN								
Nominal			1			*		V/V
Initial Error			± 0.3	± 0.5		*	*	%FSR
Gain vs Temperature			± 60	± 100		± 20	± 50	ppm/ $^\circ\text{C}$
Nonlinearity	$V_O = -10\text{V}$ to 10V $V_O = -5\text{V}$ to 5V		± 0.05	± 0.1		± 0.03	± 0.05	%FSR
			± 0.02	± 0.04		± 0.012	± 0.02	%FSR
INPUT OFFSET VOLTAGE								
Initial Offset			± 20	± 60		*	*	mV
vs Temperature			± 300	± 500		± 100	± 250	$\mu\text{V}/^\circ\text{C}$
vs Power Supplies	$V_{CC2} = \pm 10$ to $\pm 18\text{V}$		0.9			*		mV/V
vs Output Supply Load	$I_O = 0$ to $\pm 50\text{mA}$		± 0.3			*		mV/mA
SIGNAL INPUT								
Voltage Range	Output Voltage in Range	± 10	± 15		*	*		V
Resistance			200			*		k Ω
SIGNAL OUTPUT								
Voltage Range		± 10	± 12.5		*	*		V
Current Drive		± 5	± 15		*	*		mA
Ripple Voltage, 800kHz Carrier			25			*		mVp-p
	400 Ω /4.7nF (See Figure 4)		5			*		mVp-p
Capacitive Load Drive			1000			*		pF
Voltage Noise			4			*		$\mu\text{V}/\sqrt{\text{Hz}}$
FREQUENCY RESPONSE								
Small Signal Bandwidth			20			*		kHz
Slew Rate			1.5			*		V/ μs
Settling Time	0.1%, $-10/10\text{V}$		75			*		μs
POWER SUPPLIES								
Rated Voltage, V_{CC1}			± 15			*	*	V
Voltage Range		± 10		± 18		*	*	V
Input Current	$I_O = \pm 15\text{mA}$ $I_O = 0\text{mA}$		+90/-4.5 +60/-4.5			*		mA
Ripple Current	No Filter		60			*		mA
	$C_{IN} = 1\mu\text{F}$		3			*		mAp-p
Rated Output Voltage	Load = 15mA	± 14.25	± 15	± 15.75		*	*	mAp-p
Output	50mA Balanced Load	10				*		V
	100mA Single-Ended Load	10				*		V
Load Regulation	Balanced Load		0.3			*		%/mA
Line Regulation			1.12			*		V/V
Output Voltage vs Temperature			2.5			*		mV/ $^\circ\text{C}$
Voltage Balance, $\pm V_{CC2}$			0.05			*		%
Voltage Ripple (800kHz)	No External Capacitors		50			*		mVp-p
	$C_{EXT} = 1\mu\text{F}$		5			*		mVp-p
Output Capacitive Load				1			*	μF
Sync Frequency	Sync-Pin Grounded ⁽²⁾		1.6			*		MHz
TEMPERATURE RANGE								
Specification		-25		+85		*	*	$^\circ\text{C}$
Operating		-25		+85		*	*	$^\circ\text{C}$
Storage		-25		+125		*	*	$^\circ\text{C}$

* Specifications same as ISO113.

NOTE: (1) Conforms to UL1244 test methods. 100% tested at 1500Vrms for 1 minute. (2) If using external synchronization with a TTL-level clock, frequency should be between 1.2MHz and 2MHz with a duty-cycle greater than 25%.

PIN CONFIGURATION

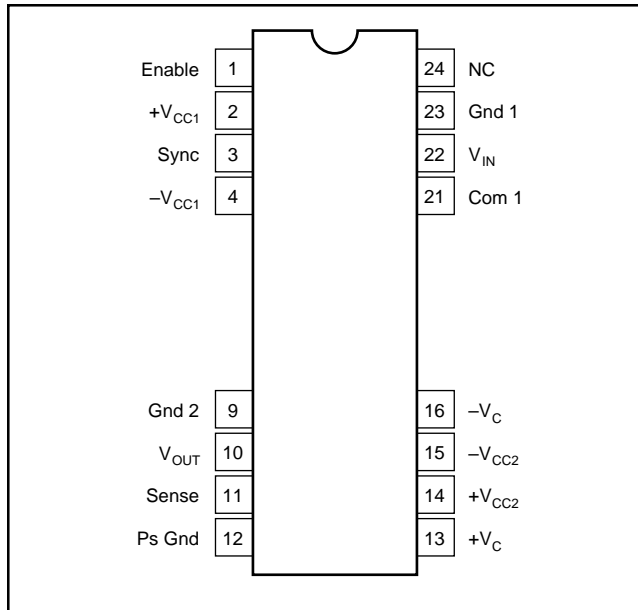

ABSOLUTE MAXIMUM RATINGS

Supply Without Damage	±18V
V _{IN} , Sense Voltage	±50V
Com ₁ to Gnd ₁	±200mV
Enable, Sync	Gnd to +V _{CC1}
Continuous Isolation Voltage	1500Vrms
V _{ISO} , dv/dt	20kV/μs
Junction Temperature	+150°C
Storage Temperature	-25°C to +125°C
Lead Temperature, 10s	+300°C
Output Short to Gnd Duration	Continuous
±V _{CC2} to Gnd 2 Duration	Continuous



ELECTROSTATIC DISCHARGE SENSITIVITY

This integrated circuit can be damaged by ESD. Burr-Brown recommends that all integrated circuits be handled with appropriate precautions. Failure to observe proper handling and installation procedures can cause damage.

ESD damage can range from subtle performance degradation to complete device failure. Precision integrated circuits may be more susceptible to damage because very small parametric changes could cause the device not to meet its published specifications.

PACKAGE/ORDERING INFORMATION

PRODUCT	PACKAGE	PACKAGE DRAWING NUMBER ⁽¹⁾	SPECIFIED TEMPERATURE RANGE	PACKAGE MARKING	ORDERING NUMBER ⁽²⁾	TRANSPORT MEDIA
ISO113	24-Pin DIP	231	-25°C to +85°C			

NOTES: (1) For detailed drawing and dimension table, please see end of data sheet, or Appendix C of Burr-Brown IC Data Book. (2) Models with a slash (/) are available only in Tape and Reel in the quantities indicated (e.g., /2K5 indicates 2500 devices per reel). Ordering 2500 pieces of "ISO113/2K5" will get a single 2500-piece Tape and Reel. For detailed Tape and Reel mechanical information, refer to Appendix B of Burr-Brown IC Data Book.

The information provided herein is believed to be reliable; however, BURR-BROWN assumes no responsibility for inaccuracies or omissions. BURR-BROWN assumes no responsibility for the use of this information, and all use of such information shall be entirely at the user's own risk. Prices and specifications are subject to change without notice. No patent rights or licenses to any of the circuits described herein are implied or granted to any third party. BURR-BROWN does not authorize or warrant any BURR-BROWN product for use in life support devices and/or systems.

TYPICAL PERFORMANCE CURVES

At $T_A = +25^\circ\text{C}$, $V_{CC1} = \pm 15\text{VDC}$, $\pm 15\text{mA}$ output, current unless otherwise noted.

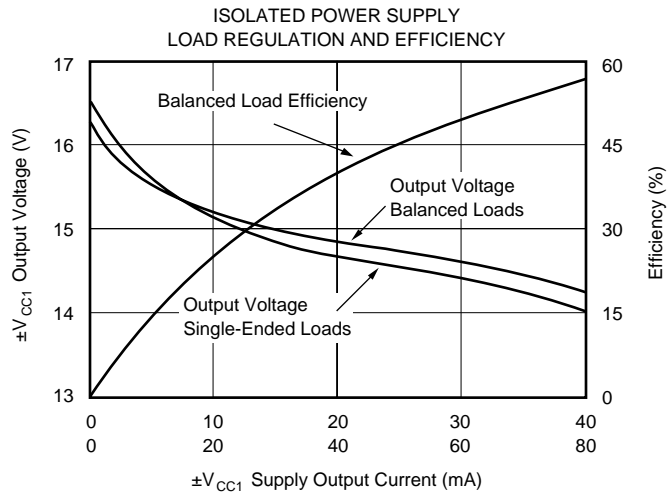
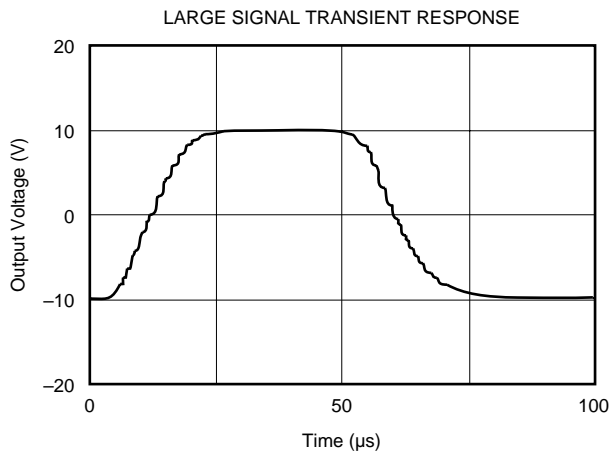
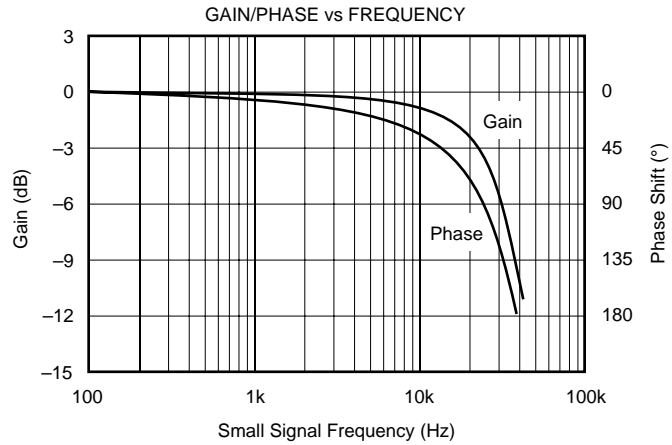
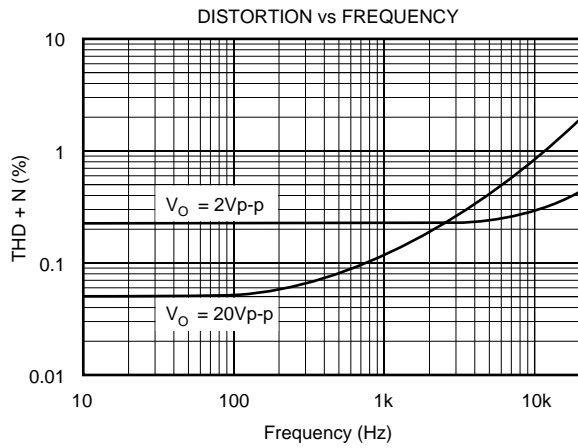
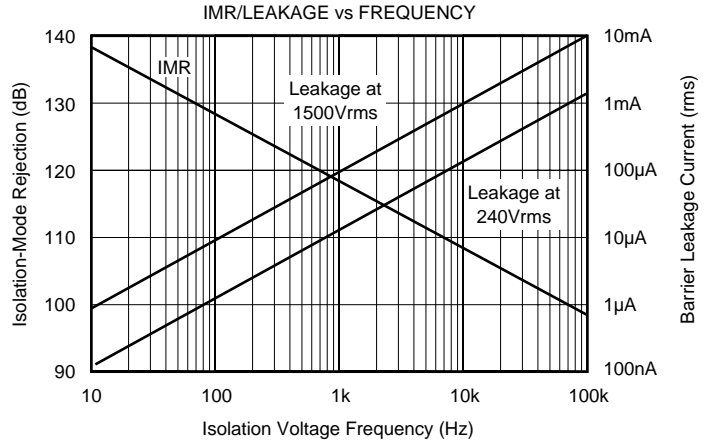
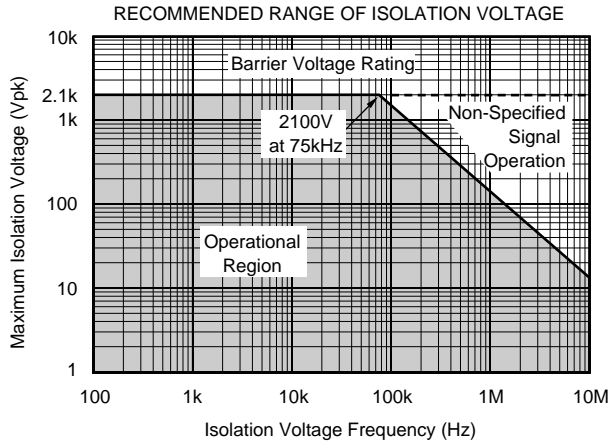

TYPICAL PERFORMANCE CURVES (CONT)

At $T_A = +25^\circ\text{C}$, $V_{CC1} = \pm 15\text{VDC}$, $\pm 15\text{mA}$ output current, unless otherwise noted.

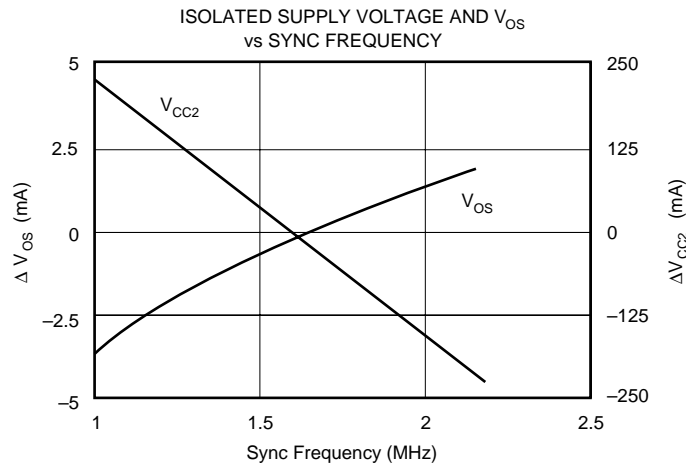
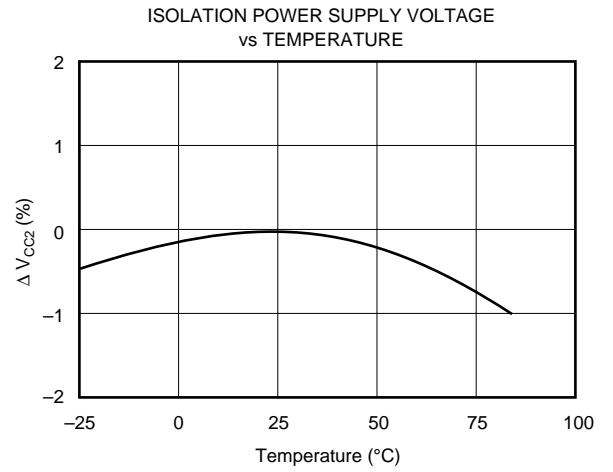
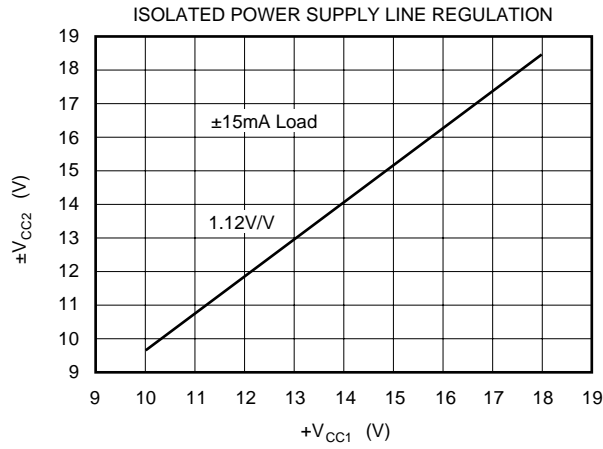

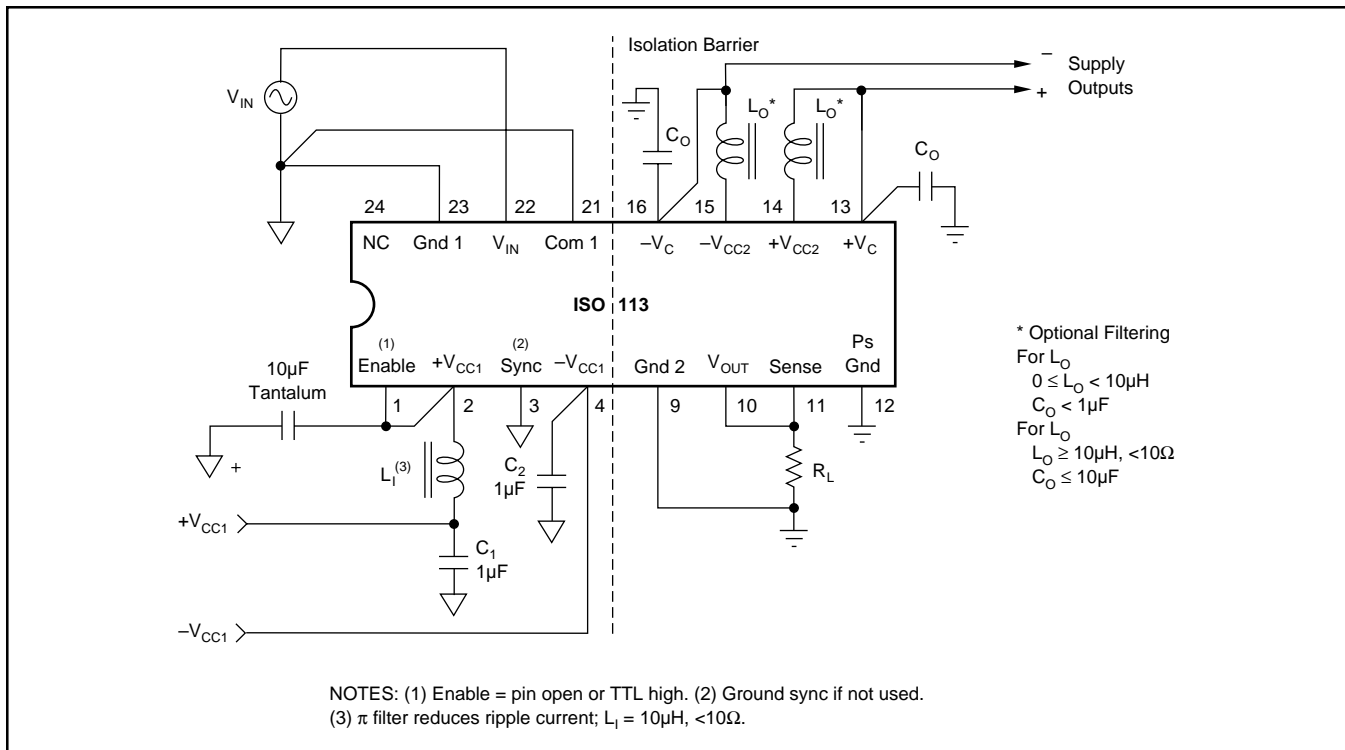

FIGURE 1. Signal and Power Connections.

THEORY OF OPERATION

The block diagram on the front page shows the isolation amplifier's synchronized signal and power configuration, which eliminate beat frequency interference. A proprietary 800kHz oscillator chip, power MOSFET transformer drivers, patented square core wirebonded transformer, and single chip diode bridge provide power to the output side of the isolation amplifier as well as external loads. The signal channel capacitively couples a duty-cycle encoded signal across the ceramic high-voltage barrier built into the package. A proprietary transmitter-receiver pair of integrated circuits, laser trimmed at wafer level, and coupled through a pair of matched "fringe" capacitors, results in a simple, reliable design.

SIGNAL AND POWER CONNECTIONS

Figure 1 shows the proper power supply and signal connections. All power supply pins should be bypassed as shown with the π filter for $+V_{CC1}$, an option recommended if more than $\pm 15\text{mA}$ are drawn from the isolated supply. Separate rectifier output pins ($\pm V_{CC2}$) and amplifier supply input pins ($\pm V_C$) allow additional ripple filtering and/or regulation. The separate input common pin and output sense are low current inputs tied to the signal source ground, and output load, respectively, to minimize errors due to IR drop in long conductors. Otherwise, connect Com 1 to Gnd 1, and Sense to V_{OUT} at the ISO113 socket. The enable pin may be left open if the ISO113 is continuously operated. If not, a TTL low level will disable the internal DC/DC converter. The Sync input must be grounded for unsynchronized operation while a 1.2MHz to 2MHz TTL clock signal provides synchronization of multiple units.

The ISO113 isolation amplifier contains a transformer-coupled DC/DC converter that is powered from the input side of the isolation amplifier. All power supply pins (2, 4, 13, 14, 15, and 16) of the ISO113 have an internal $0.1\mu\text{F}$ capacitor to ground. L_1 is used to slow down fast changes in the input current to the DC/DC converter. C_1 is used to help regulate the voltage ripple caused by the current demands of the converter. L_1 , C_1 , and C_2 are optional, however, recommended for low noise applications.

The DC/DC converter creates an unregulated $\pm 15\text{V}$ output to $\pm V_{CC2}$. If the ISO113 is the only device using the DC/DC converter for power, pins 13 and 14 and pins 15 and 16 can be connected directly without C_O or L_O in the circuit. If an external capacitor is used in this configuration, it should not exceed $1\mu\text{F}$. This configuration is possible because the isolation amplifier and the DC/DC converter are synchronized internally.

If additional devices are powered by the DC/DC converter of the ISO113, the application may require that the ripple voltage of the ISO113 converter be attenuated, in which case, L_O and C_O should be added to the circuit. The inductor is used to attenuate the ripple current and a higher value capacitor can be used to reduce the ripple voltage even further.

OPTIONAL GAIN AND OFFSET ADJUSTMENTS

Rated gain accuracy and offset performance can be achieved with no external adjustments, but the circuit of Figure 2a may be used to provide a gain trim of $\pm 0.5\%$ for the values shown. Greater range may be provided by increasing the size of R_1 and R_2 . Every $2\text{k}\Omega$ increase in R_1 will give an additional 1%

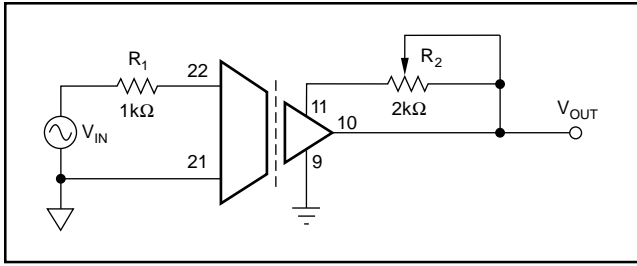

FIGURE 2a. Gain Adjust.

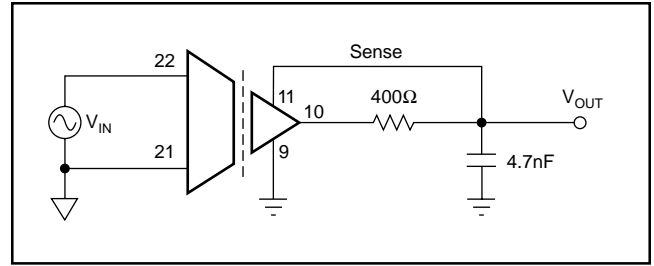

FIGURE 4. Ripple Reduction.

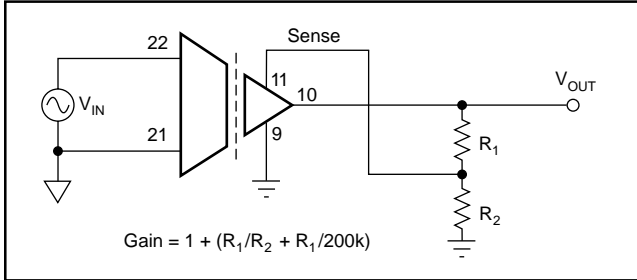

FIGURE 2b. Gain Setting.

adjustment range, with $R_2 \geq 2R_1$. If safety or convenience dictate location of the adjustment potentiometer on the other side of the barrier from the position shown in Figure 2a, the position of R_1 and R_2 may be reversed.

Gains greater than 1 may be obtained by using the circuit of Figure 2b. Note that the effect of input referred errors will be multiplied at the output in proportion to the increase in gain. Also, the small-signal bandwidth will be decreased in inverse proportion to the increase in gain. In most instances, a precision gain block at the input of the isolation amplifier will provide better overall performance.

Figure 3 shows a method for trimming V_{OS} of the ISO113. This circuit may be applied to Signal Com1. With the values shown, $\pm 15V$ supplies and unity gain, the circuit will provide $\pm 150mV$ adjustment range and $0.25mV$ resolution with a typical trim potentiometer. The output will have some sensitivity to power supply variations. For a $\pm 100mV$ trim, power supply sensitivity is $8mV/V$ at the output.

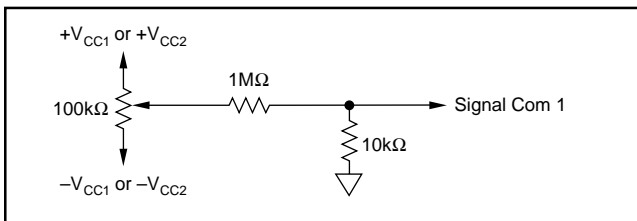

FIGURE 3. V_{OS} Adjust.

OPTIONAL OUTPUT FILTER

Figure 4 shows an optional output ripple filter that reduces the $800kHz$ ripple voltage to $<5mV_{p-p}$ without compromising DC performance. The small signal bandwidth is extended above $30kHz$ as a result of this compensation.

MULTICHANNEL SYNCHRONIZATION

Synchronization of multiple ISO113s can be accomplished by connecting pin 3 of each device to an external TTL level oscillator, as shown in Figure 7. The PWS750-1 oscillator is convenient because its nominal synchronizing output frequency is $1.6MHz$, resulting in a $800kHz$ carrier in the ISO113 (its nominal unsynchronized value). The open collector output typically switches $7.5mA$ to a $0.2V$ low level so that the external pull up resistor can be chosen for different pull up voltages as shown in Figure 7. The number of channels synchronized by one PWS750-1 is determined by the total capacitance of the sync voltage conductors. They must be less than $1000pF$ to ensure TTL level switching at $800kHz$. At higher frequencies the capacitance must be proportionally lower.

Customers can supply their own TTL level synchronization logic, provided the frequency is between $1.2MHz$ and $2MHz$, and the duty cycle is greater than 25% .

Single or multichannel synchronization with reduced power dissipation for applications requiring less than $\pm 15mA$ from V_{CC1} is accomplished by driving both the Sync input pin (3) and Enable pin (1) with the TTL oscillator as shown in Figure 5.

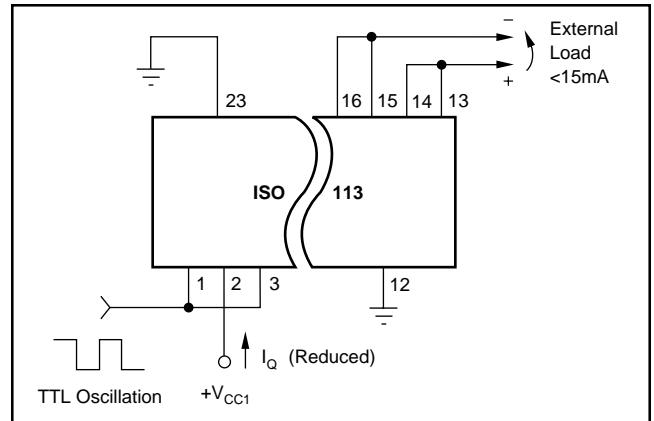

FIGURE 5. Reduced Power Dissipation.

ISOLATION BARRIER VOLTAGE

The typical performance of the ISO113 under conditions of barrier voltage stress is indicated in the first two performance curves—Recommended Range of Isolation Voltage and IMR/ Leakage vs Frequency. At low barrier modulation

levels, errors can be determined by the IMRR characteristic. At higher barrier voltages, typical performance is obtained as long as the dv/dt across the barrier is below the shaded area in the first curve. Otherwise, the signal channel will be interrupted, causing the output to distort, and/or shift DC level. This condition is temporary, with normal operation resuming as soon as the transient subsides. Permanent damage to the integrated circuits occurs only if transients exceed $20kV/\mu s$. Even in this extreme case, the barrier integrity is assured.

HIGH VOLTAGE TESTING

The ISO113 was designed to reliably operate with 1500Vrms continuous isolation barrier voltage. To confirm barrier integrity, a two-step breakdown test is performed on 100% of the units. First, an 5657V peak, 60Hz barrier potential is applied for 10s to verify that the dielectric strength of the insulation is above this level. Following this exposure, a 1500Vrms, 60Hz potential is applied for one minute to conform to UL1244. Life-test results show reliable operation under continuous rated voltage and maximum operating temperature conditions.

APPLICATIONS

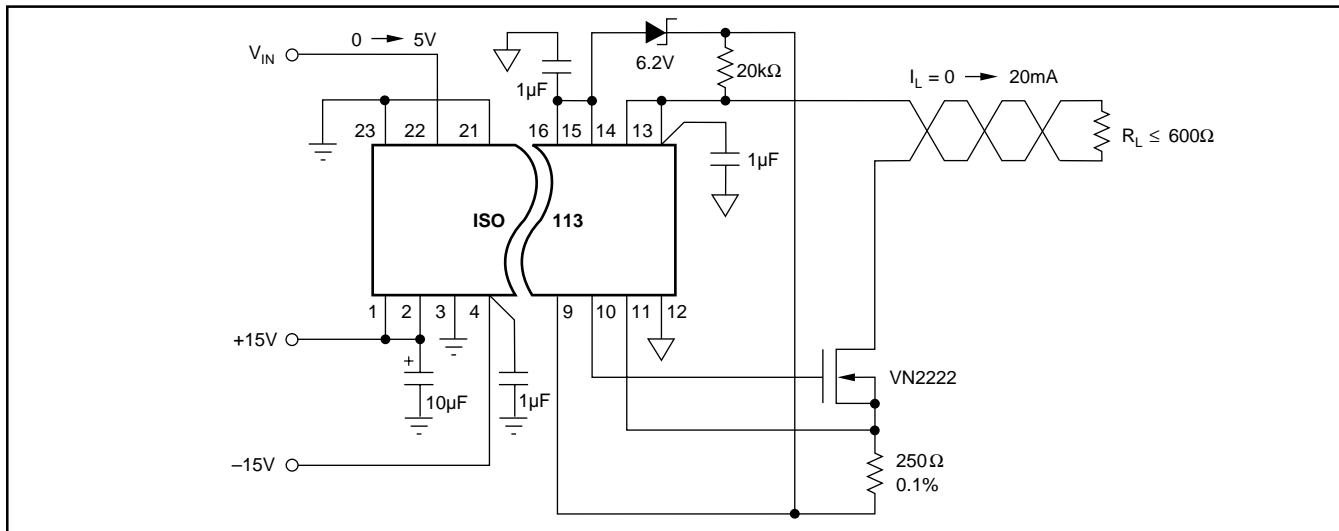

FIGURE 6. Isolated Current Loop Driver.

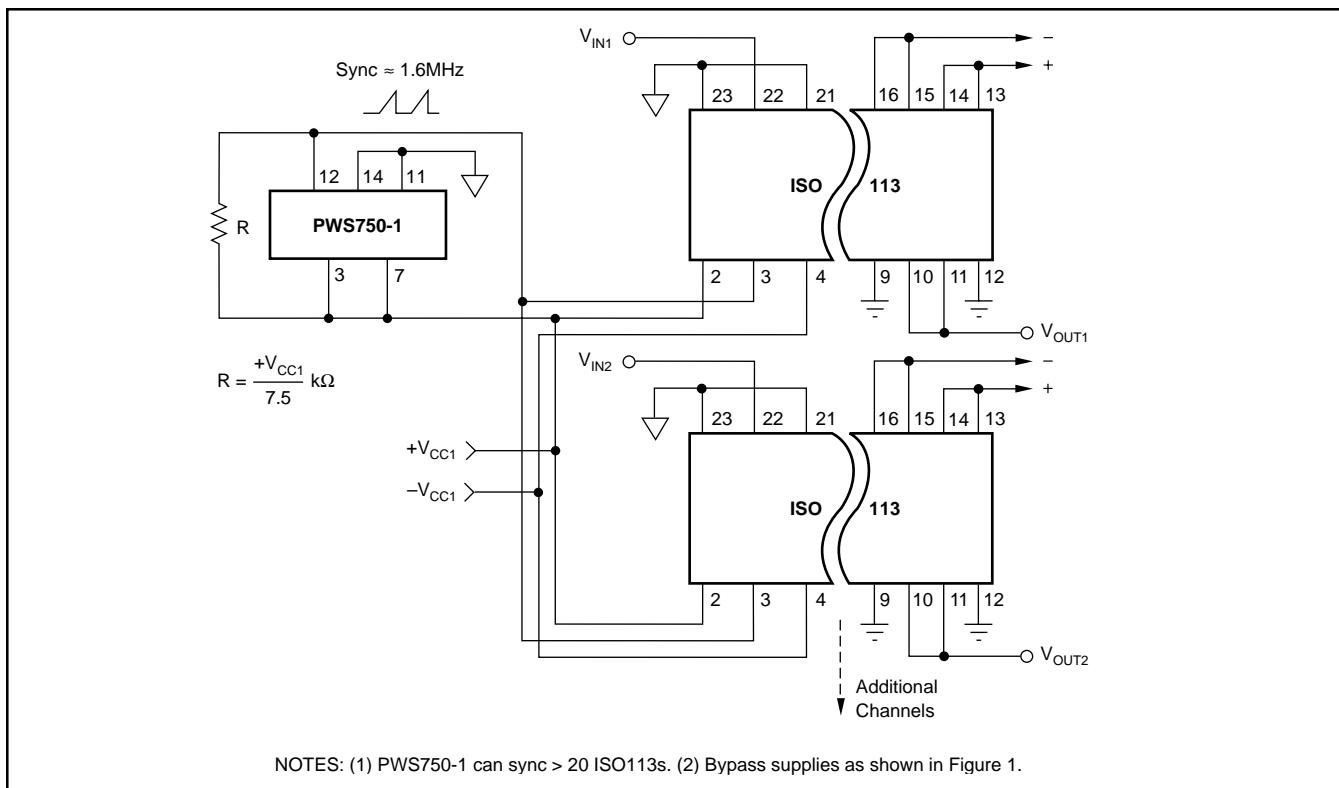

FIGURE 7. Synchronized-Multichannel Isolation.

PACKAGING INFORMATION

Orderable Device	Status (1)	Package Type	Package Drawing	Pins	Package Qty	Eco Plan (2)	Lead/Ball Finish (6)	MSL Peak Temp (3)	Op Temp (°C)	Device Marking (4/5)	Samples
ISO113	OBSOLETE	CDIP SB	JVB	16		TBD	Call TI	Call TI			
ISO113B	OBSOLETE	CDIP SB	JVB	16		TBD	Call TI	Call TI			

(1) The marketing status values are defined as follows:

ACTIVE: Product device recommended for new designs.

LIFEBUY: TI has announced that the device will be discontinued, and a lifetime-buy period is in effect.

NRND: Not recommended for new designs. Device is in production to support existing customers, but TI does not recommend using this part in a new design.

PREVIEW: Device has been announced but is not in production. Samples may or may not be available.

OBSOLETE: TI has discontinued the production of the device.

(2) Eco Plan - The planned eco-friendly classification: Pb-Free (RoHS), Pb-Free (RoHS Exempt), or Green (RoHS & no Sb/Br) - please check <http://www.ti.com/productcontent> for the latest availability information and additional product content details.

TBD: The Pb-Free/Green conversion plan has not been defined.

Pb-Free (RoHS): TI's terms "Lead-Free" or "Pb-Free" mean semiconductor products that are compatible with the current RoHS requirements for all 6 substances, including the requirement that lead not exceed 0.1% by weight in homogeneous materials. Where designed to be soldered at high temperatures, TI Pb-Free products are suitable for use in specified lead-free processes.

Pb-Free (RoHS Exempt): This component has a RoHS exemption for either 1) lead-based flip-chip solder bumps used between the die and package, or 2) lead-based die adhesive used between the die and leadframe. The component is otherwise considered Pb-Free (RoHS compatible) as defined above.

Green (RoHS & no Sb/Br): TI defines "Green" to mean Pb-Free (RoHS compatible), and free of Bromine (Br) and Antimony (Sb) based flame retardants (Br or Sb do not exceed 0.1% by weight in homogeneous material)

(3) MSL, Peak Temp. - The Moisture Sensitivity Level rating according to the JEDEC industry standard classifications, and peak solder temperature.

(4) There may be additional marking, which relates to the logo, the lot trace code information, or the environmental category on the device.

(5) Multiple Device Markings will be inside parentheses. Only one Device Marking contained in parentheses and separated by a "~" will appear on a device. If a line is indented then it is a continuation of the previous line and the two combined represent the entire Device Marking for that device.

(6) Lead/Ball Finish - Orderable Devices may have multiple material finish options. Finish options are separated by a vertical ruled line. Lead/Ball Finish values may wrap to two lines if the finish value exceeds the maximum column width.

Important Information and Disclaimer: The information provided on this page represents TI's knowledge and belief as of the date that it is provided. TI bases its knowledge and belief on information provided by third parties, and makes no representation or warranty as to the accuracy of such information. Efforts are underway to better integrate information from third parties. TI has taken and continues to take reasonable steps to provide representative and accurate information but may not have conducted destructive testing or chemical analysis on incoming materials and chemicals. TI and TI suppliers consider certain information to be proprietary, and thus CAS numbers and other limited information may not be available for release.

In no event shall TI's liability arising out of such information exceed the total purchase price of the TI part(s) at issue in this document sold by TI to Customer on an annual basis.

IMPORTANT NOTICE

Texas Instruments Incorporated and its subsidiaries (TI) reserve the right to make corrections, enhancements, improvements and other changes to its semiconductor products and services per JESD46, latest issue, and to discontinue any product or service per JESD48, latest issue. Buyers should obtain the latest relevant information before placing orders and should verify that such information is current and complete. All semiconductor products (also referred to herein as "components") are sold subject to TI's terms and conditions of sale supplied at the time of order acknowledgment.

TI warrants performance of its components to the specifications applicable at the time of sale, in accordance with the warranty in TI's terms and conditions of sale of semiconductor products. Testing and other quality control techniques are used to the extent TI deems necessary to support this warranty. Except where mandated by applicable law, testing of all parameters of each component is not necessarily performed.

TI assumes no liability for applications assistance or the design of Buyers' products. Buyers are responsible for their products and applications using TI components. To minimize the risks associated with Buyers' products and applications, Buyers should provide adequate design and operating safeguards.

TI does not warrant or represent that any license, either express or implied, is granted under any patent right, copyright, mask work right, or other intellectual property right relating to any combination, machine, or process in which TI components or services are used. Information published by TI regarding third-party products or services does not constitute a license to use such products or services or a warranty or endorsement thereof. Use of such information may require a license from a third party under the patents or other intellectual property of the third party, or a license from TI under the patents or other intellectual property of TI.

Reproduction of significant portions of TI information in TI data books or data sheets is permissible only if reproduction is without alteration and is accompanied by all associated warranties, conditions, limitations, and notices. TI is not responsible or liable for such altered documentation. Information of third parties may be subject to additional restrictions.

Resale of TI components or services with statements different from or beyond the parameters stated by TI for that component or service voids all express and any implied warranties for the associated TI component or service and is an unfair and deceptive business practice. TI is not responsible or liable for any such statements.

Buyer acknowledges and agrees that it is solely responsible for compliance with all legal, regulatory and safety-related requirements concerning its products, and any use of TI components in its applications, notwithstanding any applications-related information or support that may be provided by TI. Buyer represents and agrees that it has all the necessary expertise to create and implement safeguards which anticipate dangerous consequences of failures, monitor failures and their consequences, lessen the likelihood of failures that might cause harm and take appropriate remedial actions. Buyer will fully indemnify TI and its representatives against any damages arising out of the use of any TI components in safety-critical applications.

In some cases, TI components may be promoted specifically to facilitate safety-related applications. With such components, TI's goal is to help enable customers to design and create their own end-product solutions that meet applicable functional safety standards and requirements. Nonetheless, such components are subject to these terms.

No TI components are authorized for use in FDA Class III (or similar life-critical medical equipment) unless authorized officers of the parties have executed a special agreement specifically governing such use.

Only those TI components which TI has specifically designated as military grade or "enhanced plastic" are designed and intended for use in military/aerospace applications or environments. Buyer acknowledges and agrees that any military or aerospace use of TI components which have **not** been so designated is solely at the Buyer's risk, and that Buyer is solely responsible for compliance with all legal and regulatory requirements in connection with such use.

TI has specifically designated certain components as meeting ISO/TS16949 requirements, mainly for automotive use. In any case of use of non-designated products, TI will not be responsible for any failure to meet ISO/TS16949.

Products

Audio	www.ti.com/audio
Amplifiers	amplifier.ti.com
Data Converters	dataconverter.ti.com
DLP® Products	www.dlp.com
DSP	dsp.ti.com
Clocks and Timers	www.ti.com/clocks
Interface	interface.ti.com
Logic	logic.ti.com
Power Mgmt	power.ti.com
Microcontrollers	microcontroller.ti.com
RFID	www.ti-rfid.com
OMAP Applications Processors	www.ti.com/omap
Wireless Connectivity	www.ti.com/wirelessconnectivity

Applications

Automotive and Transportation	www.ti.com/automotive
Communications and Telecom	www.ti.com/communications
Computers and Peripherals	www.ti.com/computers
Consumer Electronics	www.ti.com/consumer-apps
Energy and Lighting	www.ti.com/energy
Industrial	www.ti.com/industrial
Medical	www.ti.com/medical
Security	www.ti.com/security
Space, Avionics and Defense	www.ti.com/space-avionics-defense
Video and Imaging	www.ti.com/video

TI E2E Community

e2e.ti.com