



LOG100

Precision LOGARITHMIC AND LOG RATIO AMPLIFIER

FEATURES

- ACCURACY
0.37% FSO max Total Error
Over 5 Decades
- LINEARITY
0.1% max Log Conformity
Over 5 Decades
- EASY TO USE
Pin-selectable Gains
Internal Laser-trimmed Resistors
- WIDE INPUT DYNAMIC RANGE
6 Decades, 1nA to 1mA
- HERMETIC CERAMIC DIP

APPLICATIONS

- LOG, LOG RATIO AND ANTILOG COMPUTATIONS
- ABSORBANCE MEASUREMENTS
- DATA COMPRESSION
- OPTICAL DENSITY MEASUREMENTS
- DATA LINEARIZATION
- CURRENT AND VOLTAGE INPUTS

DESCRIPTION

The LOG100 uses advanced integrated circuit technologies to achieve high accuracy, ease of use, low cost, and small size. It is the logical choice for your logarithmic-type computations. The amplifier has guaranteed maximum error specifications over the full six-decade input range (1nA to 1mA) and for all possible combinations of I_1 and I_2 . Total error is guaranteed so that involved error computations are not necessary.

The circuit uses a specially designed compatible thin-film monolithic integrated circuit which contains amplifiers, logging transistors, and low drift thin-film

resistors. The resistors are laser-trimmed for maximum precision. FET input transistors are used for the amplifiers whose low bias currents (1pA typical) permit signal currents as low as 1nA while maintaining guaranteed total errors of 0.37% FSO maximum.

Because scaling resistors are self-contained, scale factors of 1V, 3V or 5V per decade are obtained simply by pin selections. No other resistors are required for log ratio applications. The LOG100 will meet its guaranteed accuracy with no user trimming. Provisions are made for simple adjustments of scale factor, offset voltage, and bias current if enhanced performance is desired.

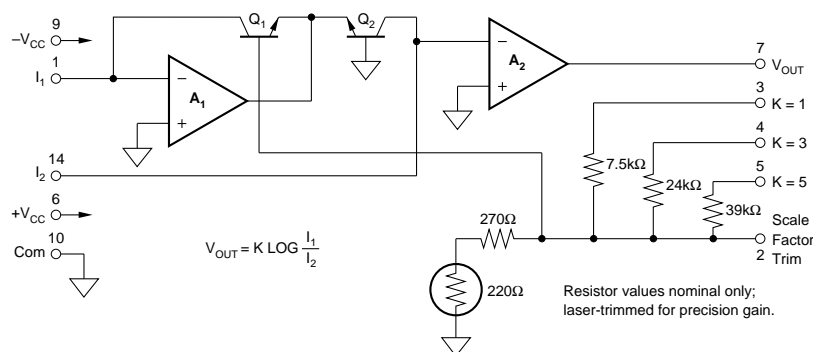

International Airport Industrial Park • Mailing Address: PO Box 11400 • Tucson, AZ 85734 • Street Address: 6730 S. Tucson Blvd. • Tucson, AZ 85706
Tel: (520) 746-1111 • Twx: 910-952-1111 • Cable: BBRCORP • Telex: 066-6491 • FAX: (520) 889-1510 • Immediate Product Info: (800) 548-6132

SPECIFICATIONS

ELECTRICAL

T_A = +25°C and ±V_{CC} = ±15V, after 15 minute warm-up, unless otherwise specified.

PARAMETER	CONDITIONS	LOG100JP			UNITS
		MIN	TYP	MAX	
TRANSFER FUNCTION Log Conformity Error ⁽¹⁾ Initial Over Temperature K Range ⁽²⁾ Accuracy Temperature Coefficient	Either I ₁ or I ₂ 1nA to 100µA (5 decades) 1nA to 1mA (6 decades) 1nA to 100µA (5 decades) 1nA to 1mA (6 decades)		V _{OUT} = K Log (I ₁ /I ₂)		
			0.04 0.15 0.002 0.001 1, 3, 5 0.3 0.03	0.1 0.25	% % %/°C %/°C V/decade % %/°C
ACCURACY Total Error ⁽³⁾ Initial vs Temperature vs Supply	K = 1, ⁽⁴⁾ Current Input Operation I ₁ , I ₂ = 1mA I ₁ , I ₂ = 100µA I ₁ , I ₂ = 10µA I ₁ , I ₂ = 1µA I ₁ , I ₂ = 100nA I ₁ , I ₂ = 10nA I ₁ , I ₂ = 1nA I ₁ , I ₂ = 1mA I ₁ , I ₂ = 100µA I ₁ , I ₂ = 10µA I ₁ , I ₂ = 1µA I ₁ , I ₂ = 100nA I ₁ , I ₂ = 10nA I ₁ , I ₂ = 1nA I ₁ , I ₂ = 1mA I ₁ , I ₂ = 100µA I ₁ , I ₂ = 10µA I ₁ , I ₂ = 1µA I ₁ , I ₂ = 100nA I ₁ , I ₂ = 10nA I ₁ , I ₂ = 1nA			±55 ±30 ±25 ±20 ±25 ±30 ±37 ±0.20 ±0.37 ±0.28 ±0.033 ±0.28 ±0.51 ±1.26 ±4.3 ±1.5 ±0.37 ±0.11 ±0.61 ±0.91 ±2.6	mV mV mV mV mV mV mV mV/°C mV/°C mV/°C mV/°C mV/°C mV/°C mV/°C mV/V mV/V mV/V mV/V mV/V mV/V mV/V
INPUT CHARACTERISTICS (of Amplifiers A ₁ and A ₂) Offset Voltage Initial vs Temperature Bias Current Initial vs Temperature Voltage Noise Current Noise	10Hz to 10kHz, RTI 10Hz to 10kHz, RTI		±0.7 ±80 1 3 0.5	±5 5 ⁽⁵⁾	mV µV/°C pA µVrms pArms
AC PERFORMANCE 3dB Response ⁽⁶⁾ , I ₂ = 10µA 1nA 1µA 10µA 1mA Step Response ⁽⁶⁾ Increasing 1µA to 1mA 100nA to 1µA 10nA to 100nA Decreasing 1mA to 1µA 1µA to 100nA 100nA to 10nA	C _C = 4500pF C _C = 150pF C _C = 150pF C _C = 50pF C _C = 150pF C _C = 150pF		0.11 38 27 45 11 7 110 45 20 550		kHz kHz kHz kHz µs µs µs µs µs µs
OUTPUT CHARACTERISTICS Full Scale Output (FSO) Rated Output Voltage Current Current Limit Positive Negative Impedance	I _{OUT} = ±5mA V _{OUT} = ±10V	±10	±10 ±5 12.5 15 0.05		V V mA mA mA Ω

SPECIFICATIONS (CONT)

ELECTRICAL

$T_A = +25^\circ\text{C}$ and $\pm V_{CC} = \pm 15\text{V}$, after 15 minute warm-up, unless otherwise specified.

PARAMETER	CONDITIONS	LOG100JP			UNITS
		MIN	TYP	MAX	
POWER SUPPLY REQUIREMENTS					
Rated Voltage			± 15		VDC
Operating Range	Derated Performance	± 12		± 18	VDC
Quiescent Current			± 7	± 9	mA
AMBIENT TEMPERATURE RANGE					
Specification		0		+70	$^\circ\text{C}$
Operating Range	Derated Performance	-25		+85	$^\circ\text{C}$
Storage		-40		+85	$^\circ\text{C}$

NOTES: (1) Log Conformity Error is the peak deviation from the best-fit straight line of the V_{OUT} vs $\text{Log } I_{IN}$ curve expressed as a percent of peak-to-peak full scale output. (2) May be trimmed to other values. See Applications section. (3) The worst-case Total Error for any ratio of I_1/I_2 is the largest of the two errors when I_1 and I_2 are considered separately. (4) Total Error at other values of K is K times Total Error for $K = 1$. (5) Guaranteed by design. Not directly measurable due to amplifier's committed configuration. (6) 3dB and transient response are a function of both the compensation capacitor and the level of input current. See Typical Performance Curves.

ABSOLUTE MAXIMUM RATINGS

Supply	$\pm 18\text{V}$
Internal Power Dissipation	600mW
Input Current	10mA
Input Voltage Range	$\pm 18\text{V}$
Storage Temperature Range	-40°C to $+85^\circ\text{C}$
Lead Temperature (soldering, 10s)	$+300^\circ\text{C}$
Output Short-circuit Duration	Continuous to ground
Junction Temperature	175°C

SCALE FACTOR PIN CONNECTIONS

K, V/DECADE	CONNECTIONS
5	5 to 7
3	4 to 7
1.9	4 and 5 to 7
1	3 to 7
0.85	3 and 5 to 7
0.77	3 and 4 to 7
0.68	3 and 4 and 5 to 7

FREQUENCY COMPENSATION

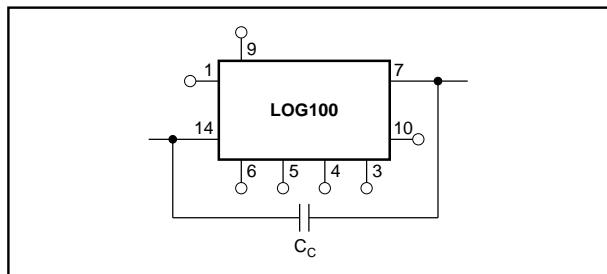

ORDERING INFORMATION

MODEL	PACKAGE	SPECIFIED TEMPERATURE RANGE
LOG100JP	14-Pin Hermetic Ceramic DIP	0°C to $+70^\circ\text{C}$

PIN CONFIGURATION

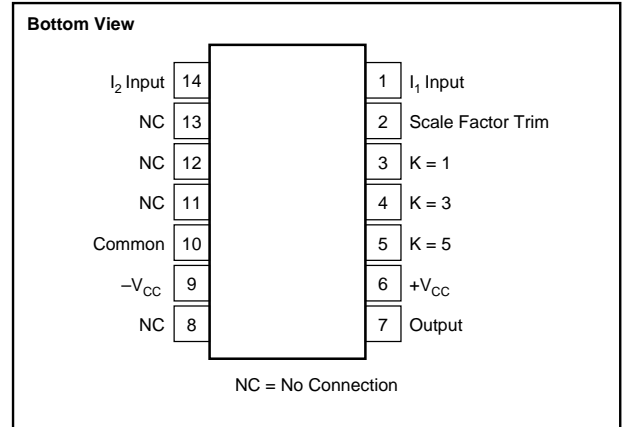

ELECTROSTATIC DISCHARGE SENSITIVITY

Any integral circuit can be damaged by ESD. Burr-Brown recommends that all integrated circuits be handled with appropriate precautions. Failure to observe proper handling and installation procedures can cause damage.

ESD damage can range from subtle performance degradation to complete device failure. Precision integrated circuits may be more susceptible to damage because very small parametric changes could cause the device not to meet published specifications.

PACKAGE INFORMATION

MODEL	PACKAGE	PACKAGE DRAWING NUMBER ⁽¹⁾
LOG100JP	14-Pin Hermetic Ceramic DIP	148 ⁽²⁾

NOTES: (1) For detailed drawing and dimension table, please see end of data sheet, or Appendix D of Burr-Brown IC Data Book. (2) During 1994, the package was changed from plastic to hermetic ceramic. Pinout, model number, and specifications remained unchanged. The metal lid of the new package is internally connected to common, pin 10.

TYPICAL PERFORMANCE CURVES

$T_A = +25^\circ\text{C}$, $V_{CC} = \pm 15\text{VDC}$, unless otherwise noted.

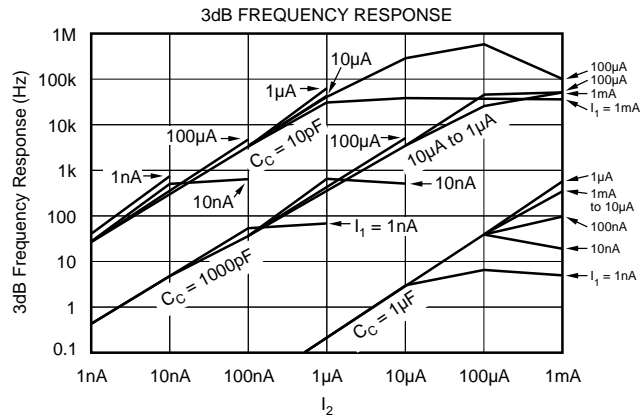
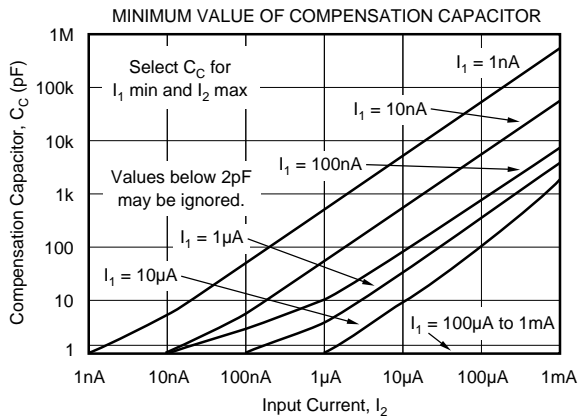
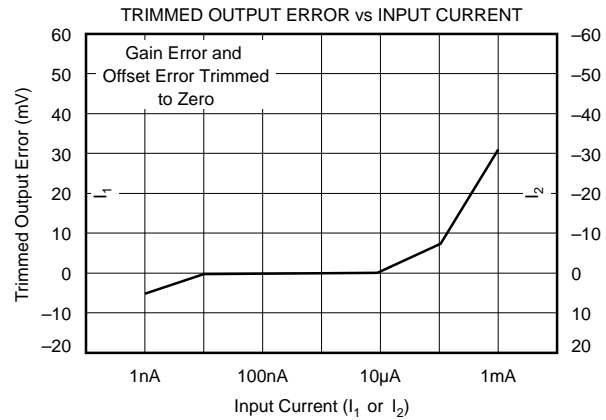
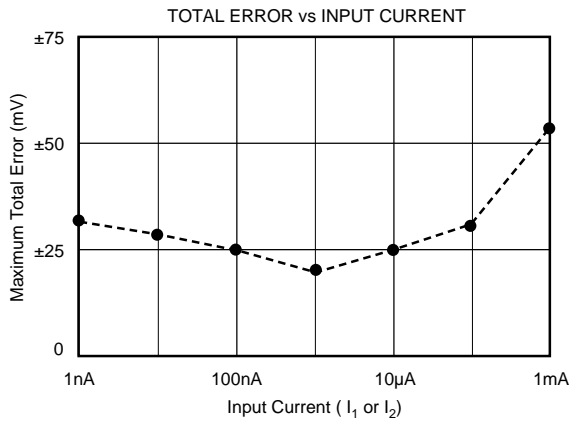
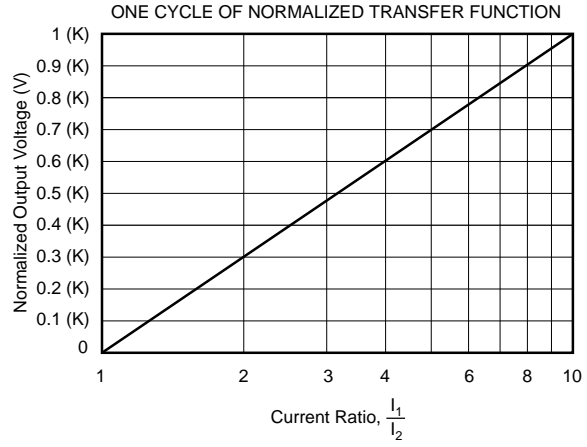
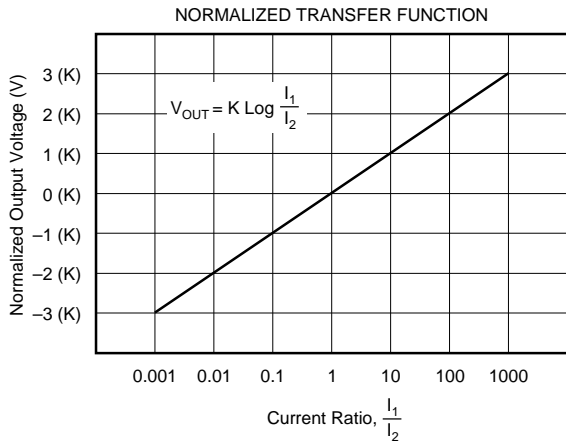

THEORY OF OPERATION

The base-emitter voltage of a bipolar transistor is

$$V_{BE} = V_T \ln \frac{I_C}{I_S} \quad \text{where: } V_T = \frac{KT}{q} \quad (1)$$

K = Boltzman's constant = 1.381×10^{-23}

T = Absolute temperature in degrees Kelvin

q = Electron charge = 1.602×10^{-19} Coulombs

I_C = Collector current

I_S = Reverse saturation current

From the circuit in Figure 1, we see that

$$V_{OUT}' = V_{BE1} - V_{BE2} \quad (2)$$

Substituting (1) into (2) yields

$$V_{OUT}' = V_{T1} \ln \frac{I_1}{I_{S1}} - V_{T2} \ln \frac{I_1}{I_{S2}} \quad (3)$$

If the transistors are matched and isothermal and $V_{T1} = V_{T2}$, then (3) becomes:

$$V_{OUT}' = V_T \left[\ln \frac{I_1}{I_S} - \ln \frac{I_2}{I_S} \right] \quad (4)$$

$$V_{OUT}' = V_T \ln \frac{I_1}{I_2} \quad \text{and since} \quad (5)$$

$$\ln x = 2.3 \log_{10} x \quad (6)$$

$$V_{OUT}' = n V_T \log \frac{I_1}{I_2} \quad (7)$$

where $n = 2.3$

also

$$V_{OUT} = V_{OUT}' \frac{R_1 + R_2}{R_1} \quad (8)$$

$$= \frac{R_1 + R_2}{R_1} n V_T \log \frac{I_1}{I_2} \quad (9)$$

or

$$V_{OUT} = K \log \frac{I_1}{I_2} \quad (10)$$

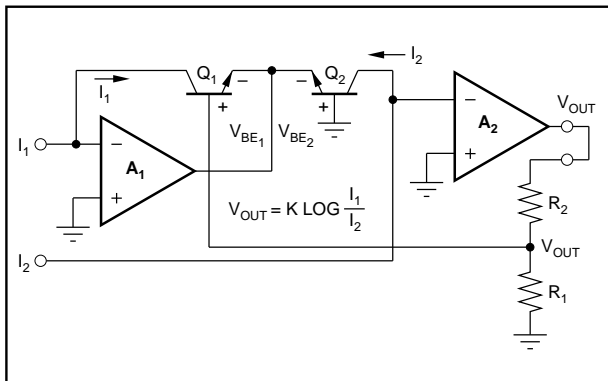

FIGURE 1. Simplified Model of Log Amplifier.

It should be noted that the temperature dependence associated with $V_T = KT/q$ is compensated by making R_1 a temperature sensitive resistor with the required positive temperature coefficient.

DEFINITION OF TERMS

TRANSFER FUNCTION

The ideal transfer function is $V_{OUT} = K \log \frac{I_1}{I_2}$ where:

K = the scale factor with units of volts/decade

I_1 = numerator input current

I_2 = denominator input current.

ACCURACY

Accuracy considerations for a log ratio amplifier are somewhat more complicated than for other amplifiers. The reason is that the transfer function is nonlinear and has two inputs, each of which can vary over a wide dynamic range. The accuracy for any combination of inputs is determined from the total error specification.

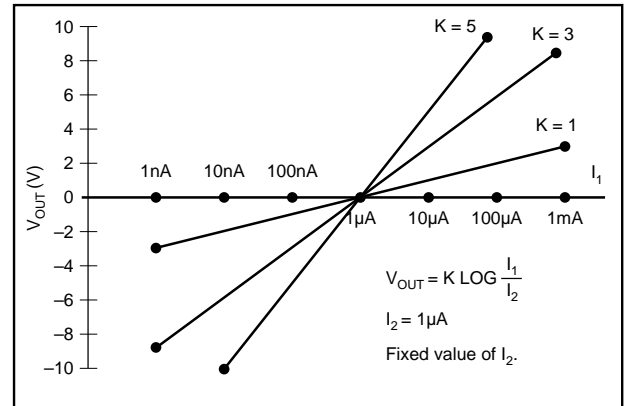

FIGURE 2. Transfer Function with Varying K and I_1 .

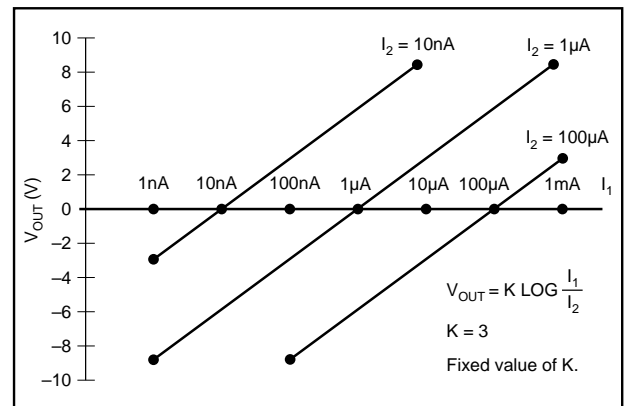

FIGURE 3. Transfer Function with Varying I_2 and I_1 .

TOTAL ERROR

The total error is the deviation (expressed in mV) of the actual output from the ideal output of $V_{OUT} = K \log (I_1/I_2)$. Thus,

$$V_{OUT (ACTUAL)} = V_{OUT (IDEAL)} \pm \text{Total Error.}$$

It represents the sum of all the individual components of error normally associated with the log amp when operated in the current input mode. The worst-case error for any given ratio of I_1/I_2 is the largest of the two errors when I_1 and I_2 are considered separately.

Example:

I_1 varies over a range of 10nA to 1 μ A and I_2 varies from 100nA to 10 μ A. What is the maximum error?

Table I shows the maximum errors for each decade combination of I_1 and I_2 .

		I_1 (maximum error) ⁽¹⁾		
		10nA (30mV)	100nA (25mV)	1 μ A (20mV)
I_2 (maximum error) ⁽¹⁾	100nA (25mV)	0.1 (30mV)	1 (25mV)	10 (25mV)
	1 μ A (20mV)	0.01 (30mV)	0.1 (25mV)	1 (20mV)
	10 μ A (25mV)	0.001 (30mV)	0.01 (25mV)	0.1 (25mV)

NOTE: (1) Maximum errors are in parenthesis.

TABLE I. I_1/I_2 and Maximum Errors.

Since the largest value of I_1/I_2 is 10 and the smallest is 0.001, K is set at 3V per decade so the output will range from +3V to -9V. The maximum total error occurs when $I_1 = 10$ nA and is equal to $K \times 30$ mV. This represents a 0.75% of peak-to-peak FSO error $3 \times 0.030/12 \times 100\% = 0.75\%$ where the full scale output is 12V (from +3V to -9V).

ERRORS RTO AND RTI

As with any transfer function, errors generated by the function itself may be Referred-to-Output (RTO) or Referred-to-Input (RTI). In this respect, log amps have a unique property:

Given some error voltage at the log amp's output, that error corresponds to a constant percent of the input regardless of the actual input level.

Refer to: Yu Jen Wong and William E. Ott, "Function Circuits: Design & Applications", McGraw-Hill Book, 1976.

LOG CONFORMITY

Log conformity corresponds to linearity when V_{OUT} is plotted versus I_1/I_2 on a semilog scale. In many applications, log conformity is the most important specification. This is true because bias current errors are negligible (1pA compared to input currents of 1nA and above) and the scale factor and offset errors may be trimmed to zero or removed by system calibration. This leaves log conformity as the major source of error.

Log conformity is defined as the peak deviation from the best-fit straight line of the V_{OUT} versus $\log (I_1/I_2)$ curve. This is expressed as a percent of peak-to-peak full scale output. Thus, the nonlinearity error expressed in volts over m decades is

$$V_{OUT (NONLIN)} = K \text{ 2Nm V} \quad (12)$$

where N is the log conformity error, in percent.

INDIVIDUAL ERROR COMPONENTS

The ideal transfer function with current input is

$$V_{OUT} = K \text{ Log } \frac{I_1}{I_2} \quad (13)$$

The actual transfer function with the major components of error is

$$V_{OUT} = K (1 \pm \Delta K) \log \frac{I_1 - I_{B1}}{I_2 - I_{B2}} \pm K \text{ 2Nm } \pm V_{OS OUT} \quad (14)$$

The individual component of error is

ΔK = scale factor error (0.3%, typ)

I_{B1} = bias current of A_1 (1pA, typ)

I_{B2} = bias current of A_2 (1pA, typ)

N = log conformity error (0.05%, 0.1%, typ)

$V_{OS OUT}$ = output offset voltage (1mV, typ)

m = number of decades over which N is specified:

0.05% for m = 5, 0.1% for m = 6

Example: what is the error with K = 3 when

$I_1 = 1\mu$ A and $I_2 = 100$ nA

$$V_{OUT} = 3(1 \pm 0.003) \log \frac{10^{-6} - 10^{-12}}{10^{-7} - 10^{-12}} \pm 3(2)(0.0005)5 \pm 1\text{mV} \quad (15)$$

$$\approx 3.009 \log \frac{10^{-6}}{10^{-7}} + 0.015 + 0.001 \quad (16)$$

$$= 3.009 (1) + 0.015 + 0.001 \quad (17)$$

$$= 3.025\text{V} \quad (18)$$

Since the ideal output is 3.000V, the error as a percent of reading is

$$\% \text{ error} = \frac{0.025}{3} \times 100\% = 0.83\% \quad (19)$$

For the case of voltage inputs, the actual transfer function is

$$V_{OUT} = K(1 \pm \Delta K) \log \frac{\frac{V_1}{R_1} - I_{B1} \pm \frac{E_{OS1}}{R_1}}{\frac{V_2}{R_2} - I_{B2} \pm \frac{E_{OS2}}{R_2}} \pm K \text{ 2Nm } \pm V_{OS OUT} \quad (20)$$

FREQUENCY RESPONSE

The 3dB frequency response of the LOG100 is a function of the magnitude of the input current levels and of the value of the frequency compensation capacitor. See Typical Performance Curves for details.

The frequency response curves are shown for constant DC I_1 and I_2 with a small signal AC current on one of them.

The transient response of the LOG100 is different for increasing and decreasing signals. This is due to the fact that a log amp is a nonlinear gain element and has different gains at different levels of input signals. Frequency response decreases as the gain increases.

GENERAL INFORMATION

INPUT CURRENT RANGE

The stated input range of 1nA to 1mA is the range for specified accuracy. Smaller or larger input currents may be applied with decreased accuracy. Currents larger than 1mA result in increased nonlinearity. The 10mA absolute maximum is a conservative value to limit the power dissipation in the output stage of A_1 and the logging transistor. Currents below 1nA will result in increased errors due to the input bias currents of A_1 and A_2 (1pA typical). These errors may be nulled. See Optional Adjustments section.

FREQUENCY COMPENSATION

Frequency compensation for the LOG100 is obtained by connecting a capacitor between pins 7 and 14. The size of the capacitor is a function of the input currents as shown in the Typical Performance Curves. For any given application, the smallest value of the capacitor which may be used is determined by the maximum value at I_2 and the minimum value of I_1 . Larger values of C_C will make the LOG100 more stable, but will reduce the frequency response.

SETTING THE REFERENCE CURRENT

When the LOG100 is used as a straight log amplifier I_2 is constant and becomes the reference current in the expression

$$V_{\text{OUT}} = K \log \frac{I_1}{I_{\text{REF}}} \quad (21)$$

I_{REF} can be derived from an external current source (such as shown in Figure 4), or it may be derived from a voltage source with one or more resistors.

When a single resistor is used, the value may be quite large when I_{REF} is small. If I_{REF} is 10nA and $+15\text{V}$ is used

$$R_{\text{REF}} = \frac{15\text{V}}{10\text{nA}} = 1500\text{M}\Omega.$$

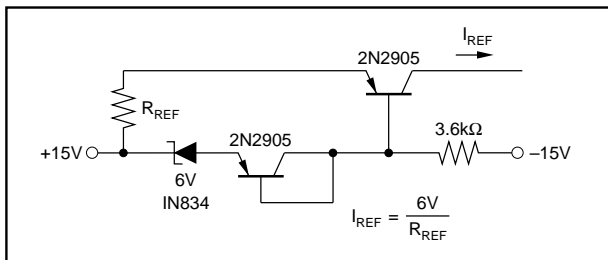

FIGURE 4. Temperature-Compensated Current Reference.

A voltage divider may be used to reduce the value of the resistor. When this is done, one must be aware of possible errors caused by the amplifier's input offset voltage. This is shown in Figure 5.

In this case the voltage at pin 14 is not exactly zero, but is equal to the value of the input offset voltage of A_1 , which ranges from zero to $\pm 5\text{mV}$. V_T must be kept much larger than 5mV in order to make this effect negligible. This concept also applies to pin 1.

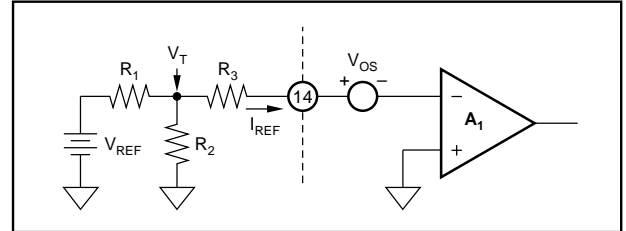

FIGURE 5. "T" Network for Reference Current.

OPTIONAL ADJUSTMENTS

The LOG100 will meet its specified accuracy with no user adjustments. If improved performance is desired, the following optional adjustments may be made.

INPUT BIAS CURRENT

The circuit in Figure 6 may be used to compensate for the input bias currents of A_1 and A_2 . Since the amplifiers have FET inputs with the characteristic bias current doubling every 10°C , this nulling technique is practical only where the temperature is fairly stable.

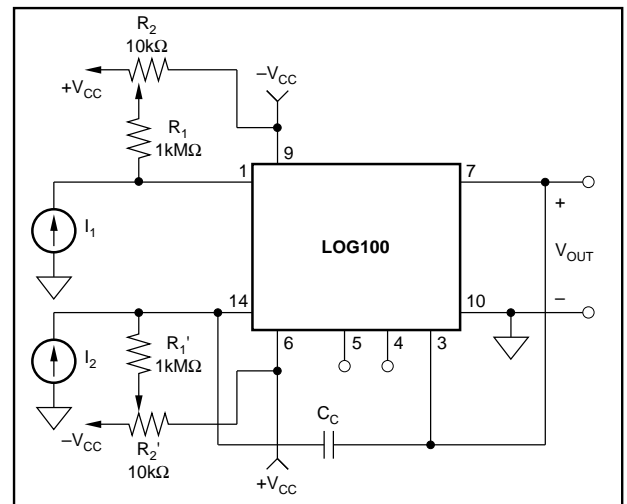

FIGURE 6. Bias Current Nulling.

OUTPUT OFFSET

The output offset may be nulled with the circuit in Figure 7. I_1 and I_2 are set equal at some convenient value in the range of 100nA to 100μA . R_1 is then adjusted for zero output voltage.

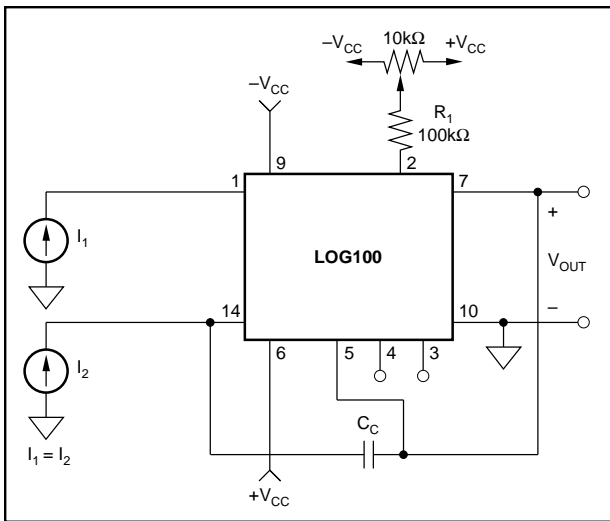

FIGURE 7. Output Offset Nulling.

ADJUSTMENTS OF SCALE FACTOR K

The value of K may be changed by increasing or decreasing the voltage divider resistor normally connected to the output, pin 7. To increase K put resistance in series between pin 7 and the appropriate scaling resistor pin (3, 4 or 5). To decrease K place a parallel resistor between pin 2 and either pin 3, 4 or 5.

APPLICATION INFORMATION

WIRING PRECAUTIONS

In order to prevent frequency instability due to lead inductance of the power supply lines, each power supply should be bypassed. This should be done by connecting a 10μF tantalum capacitor in parallel with a 1000pF ceramic capacitor from the +V_{CC} and -V_{CC} pins to the power supply common. The connection of these capacitors should be as close to the LOG100 as practical.

CAPACITIVE LOADS

Stable operation is maintained with capacitive loads of up to 100pF, typically. Higher capacitive loads can be driven if a 22Ω carbon resistor is connected in series with the LOG100's output. This resistor will, of course, form a voltage divider with other resistive loads.

CIRCUIT PROTECTION

The LOG100 can be protected against accidental power supply reversal by putting a diode (1N4001 type) in series with each power supply line as shown in Figure 8. This precaution is necessary only in power systems that momentarily reverse polarity during turn-on or turn-off. If this protection circuit is used, the accuracy of the LOG100 will be degraded slightly by the voltage drops across the diodes as determined by the power supply sensitivity specification.

The LOG100 uses small geometry FET transistors to achieve the low input bias currents. Normal FET handling

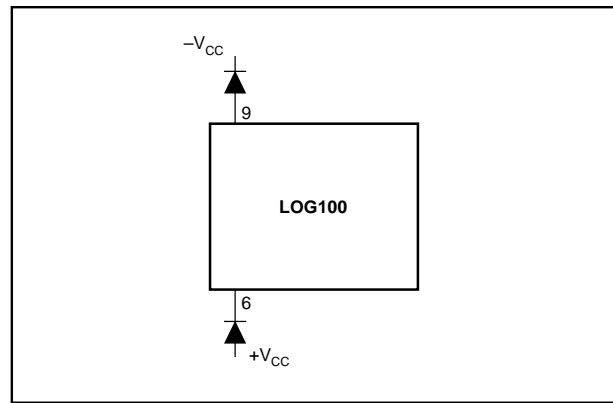

FIGURE 8. Reverse Polarity Protection.

techniques should be used to avoid damage caused by low energy electrostatic discharge (ESD).

LOG RATIO

One of the more common uses of log ratio amplifiers is to measure absorbance. A typical application is shown in Figure 9.

$$\text{Absorbance of the sample is } A = \log \frac{\lambda_1'}{\lambda_1} \quad (22)$$

$$\text{If } \lambda_2 = \lambda_1 \text{ and } D_1 \text{ and } D_2 \text{ are matched } A \propto K \log \frac{I_1}{I_2} \quad (23)$$

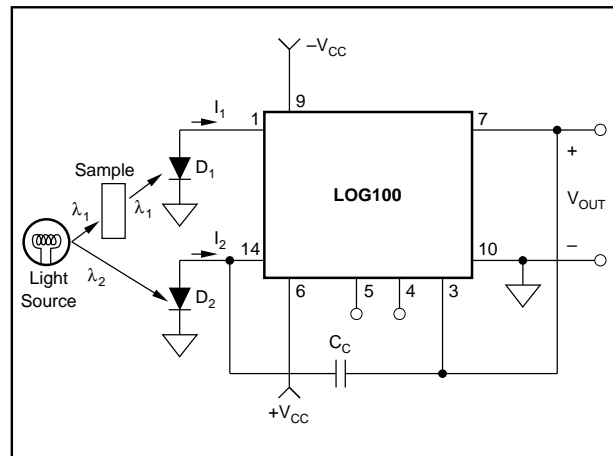

FIGURE 9. Absorbance Measurement.

DATA COMPRESSION

In many applications the compressive effects of the logarithmic transfer function is useful. For example, a LOG100 preceding an 8-bit analog-to-digital converter can produce equivalent 20-bit converter operation.

SELECTING OPTIMUM VALUES OF I₂ AND K

In straight log applications (as opposed to log ratio), both K and I₂ are selected by the designer. In order to minimize errors due to output offset and noise, it is normally best to

scale the log amp to use as much of the $\pm 10V$ output range as possible. Thus, with the range of I_1 from $I_{1\text{ MIN}}$ to $I_{1\text{ MAX}}$:

$$\text{For } I_{1\text{ MAX}} \quad +10V = K \log I_{1\text{ MAX}}/I_2 \quad (24)$$

$$\text{For } I_{1\text{ MIN}} \quad -10V = K \log I_{1\text{ MIN}}/I_2 \quad (25)$$

Addition of these two equations and solving for I_2 shows that its optimum value, $I_{2\text{ OPT}}$, is the geometric mean of $I_{1\text{ MAX}}$ and $I_{1\text{ MIN}}$.

$$I_{2\text{ OPT}} = \sqrt{I_{1\text{ MAX}} \times I_{1\text{ MIN}}} \quad (26)$$

$$K_{\text{OPT}} = \frac{10}{\log \frac{I_{1\text{ MAX}}}{I_{2\text{ OPT}}}} \quad (27)$$

Since K is selectable in discrete steps, use the largest value of K available which does not exceed K_{OPT} .

NEGATIVE INPUT CURRENTS

The LOG100 will function only with positive input currents (conventional current flow into pins 1 and 14). Some current sources (such as photomultiplier tubes) provide negative input currents. In such situations, the circuit in Figure 10 may be used.⁽¹⁾

VOLTAGE INPUTS

The LOG100 gives the best performance with current inputs. Voltage inputs may be handled directly with series resistors, but the dynamic input range is limited to approximately three decades of input voltage by voltage noise and offsets. The transfer function of equation (20) applies to this configuration.

NOTE: (1) More detailed information may be found in "Properly Designed Log Amplifiers Process Bipolar Input Signals" by Larry McDonald, EDN, 5 Oct. 80, pp 99-102.

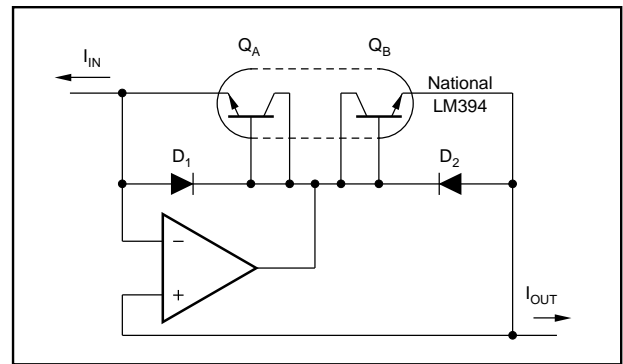

FIGURE 10. Current Inverter.

ANTILOG CONFIGURATION (an implicit technique)

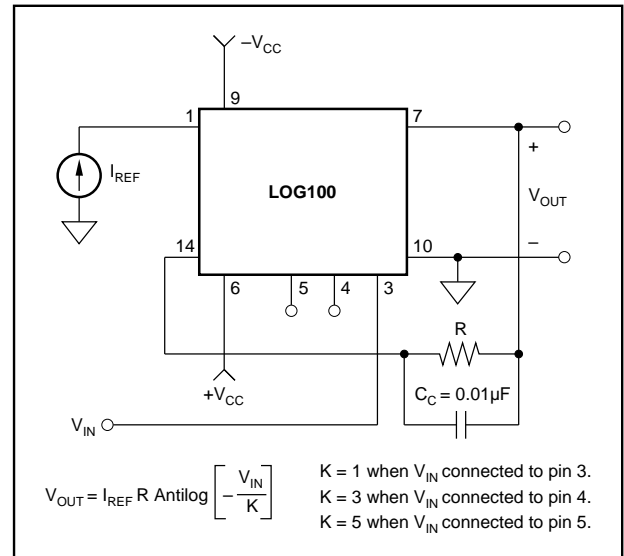

FIGURE 11. Connections for Antilog Function.

The information provided herein is believed to be reliable; however, BURR-BROWN assumes no responsibility for inaccuracies or omissions. BURR-BROWN assumes no responsibility for the use of this information, and all use of such information shall be entirely at the user's own risk. Prices and specifications are subject to change without notice. No patent rights or licenses to any of the circuits described herein are implied or granted to any third party. BURR-BROWN does not authorize or warrant any BURR-BROWN product for use in life support devices and/or systems.

PACKAGING INFORMATION

ORDERABLE DEVICE	STATUS(1)	PACKAGE TYPE	PACKAGE DRAWING	PINS	PACKAGE QTY
LOG100JP	NRND	CDIP BB	JDE	14	25
LOG100JP-2	NRND	CDIP BB	JDE	14	

(1) The marketing status values are defined as follows:

ACTIVE: Product device recommended for new designs.

LIFEBUY: TI has announced that the device will be discontinued, and a lifetime-buy period is in effect.

NRND: Not recommended for new designs. Device is in production to support existing customers, but TI does not recommend using this part in a new design.

PREVIEW: Device has been announced but is not in production. Samples may or may not be available.

OBSOLETE: TI has discontinued the production of the device.

IMPORTANT NOTICE

Texas Instruments Incorporated and its subsidiaries (TI) reserve the right to make corrections, modifications, enhancements, improvements, and other changes to its products and services at any time and to discontinue any product or service without notice. Customers should obtain the latest relevant information before placing orders and should verify that such information is current and complete. All products are sold subject to TI's terms and conditions of sale supplied at the time of order acknowledgment.

TI warrants performance of its hardware products to the specifications applicable at the time of sale in accordance with TI's standard warranty. Testing and other quality control techniques are used to the extent TI deems necessary to support this warranty. Except where mandated by government requirements, testing of all parameters of each product is not necessarily performed.

TI assumes no liability for applications assistance or customer product design. Customers are responsible for their products and applications using TI components. To minimize the risks associated with customer products and applications, customers should provide adequate design and operating safeguards.

TI does not warrant or represent that any license, either express or implied, is granted under any TI patent right, copyright, mask work right, or other TI intellectual property right relating to any combination, machine, or process in which TI products or services are used. Information published by TI regarding third-party products or services does not constitute a license from TI to use such products or services or a warranty or endorsement thereof. Use of such information may require a license from a third party under the patents or other intellectual property of the third party, or a license from TI under the patents or other intellectual property of TI.

Reproduction of information in TI data books or data sheets is permissible only if reproduction is without alteration and is accompanied by all associated warranties, conditions, limitations, and notices. Reproduction of this information with alteration is an unfair and deceptive business practice. TI is not responsible or liable for such altered documentation.

Resale of TI products or services with statements different from or beyond the parameters stated by TI for that product or service voids all express and any implied warranties for the associated TI product or service and is an unfair and deceptive business practice. TI is not responsible or liable for any such statements.

Following are URLs where you can obtain information on other Texas Instruments products and application solutions:

Products		Applications	
Amplifiers	amplifier.ti.com	Audio	www.ti.com/audio
Data Converters	dataconverter.ti.com	Automotive	www.ti.com/automotive
DSP	dsp.ti.com	Broadband	www.ti.com/broadband
Interface	interface.ti.com	Digital Control	www.ti.com/digitalcontrol
Logic	logic.ti.com	Military	www.ti.com/military
Power Mgmt	power.ti.com	Optical Networking	www.ti.com/opticalnetwork
Microcontrollers	microcontroller.ti.com	Security	www.ti.com/security
		Telephony	www.ti.com/telephony
		Video & Imaging	www.ti.com/video
		Wireless	www.ti.com/wireless

Mailing Address: Texas Instruments
Post Office Box 655303 Dallas, Texas 75265

Copyright © 2003, Texas Instruments Incorporated