

# ADS8353-Q1 Automotive, 16-Bit, 2-Channel, Simultaneous-Sampling, 600-kSPS, Analog-to-Digital Converter

## 1 Features

- AEC-Q100 qualified for automotive applications:
  - Temperature grade 1:  $-40^{\circ}\text{C}$  to  $+125^{\circ}\text{C}$ ,  $T_A$
  - Device HBM ESD classification level 2
  - Device CDM ESD classification level C4B
- **Functional Safety-Capable**
  - [Documentation available to aid functional safety system design](#)
- 16-bit resolution
- Simultaneous sampling of two channels
- Supports single-ended and pseudo-differential inputs
- Two software-selectable, unipolar input ranges:
  - (0 V to  $V_{REF}$ ) or (0 V to  $2x V_{REF}$ )
- Up to 600-kSPS sampling speed
- Excellent dc performance:
  - $\pm 0.6$ -LSB DNL
  - $\pm 1$ -LSB INL
  - $\pm 0.05\%$  gain error
- Excellent ac performance:
  - 89-dB SNR
  - $-100$ -dB THD
- Dual, low-drift (10 ppm/ $^{\circ}\text{C}$ ), programmable 2.5-V internal reference

## 2 Applications

- [Battery management systems \(BMS\)](#)
- [DC/DC converters](#)
- [Energy storage power conversion systems \(PCS\)](#)
- [Solar arc protection](#)

## 3 Description

The ADS8353-Q1 is a 16-bit, dual-channel, high-speed, simultaneous-sampling, analog-to-digital converter (ADC) that supports single-ended and pseudo-differential analog inputs.

The ADS8353-Q1 includes two individually programmable reference sources that can be used for system-level gain calibration. Also, a flexible serial interface that can operate over a wide power-supply range enables easy communication with a large variety of host controllers. Power consumption for a given throughput can be optimized by using the two low-power modes supported by the device. The ADS8353-Q1 is fully specified over the temperature range ( $-40^{\circ}\text{C}$  to  $+125^{\circ}\text{C}$ ) and is available in a 16-pin TSSOP package.

### Package Information<sup>(1)</sup>

PART NUMBER	PACKAGE	BODY SIZE (NOM)
ADS8353-Q1	TSSOP (16)	5.00 mm × 4.40 mm

(1) For all available packages, see the orderable addendum at the end of the data sheet.

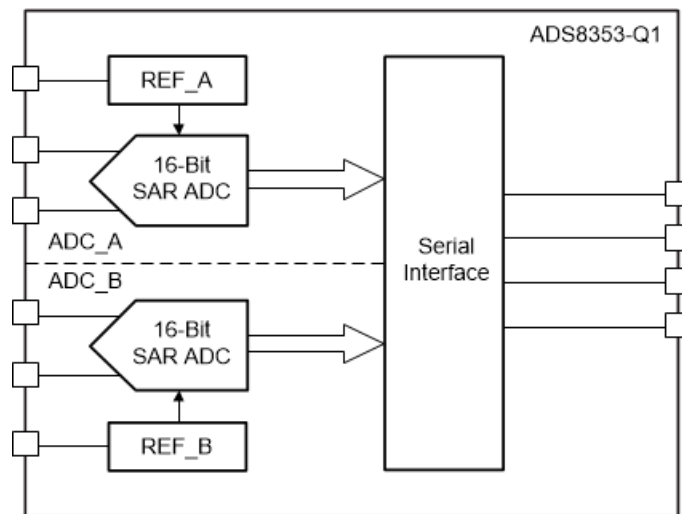

Typical Application Diagram



## Table of Contents

<b>1 Features</b> .....	1	7.3 Feature Description.....	14
<b>2 Applications</b> .....	1	7.4 Device Functional Modes.....	20
<b>3 Description</b> .....	1	7.5 Programming.....	20
<b>4 Revision History</b> .....	2	7.6 Register Maps.....	27
<b>5 Pin Configuration and Functions</b> .....	3	<b>8 Application and Implementation</b> .....	31
<b>6 Specifications</b> .....	4	8.1 Application Information.....	31
6.1 Absolute Maximum Ratings.....	4	8.2 Typical Application.....	33
6.2 ESD Ratings.....	4	8.3 Power Supply Recommendations.....	34
6.3 Thermal Information.....	4	8.4 Layout.....	35
6.4 Recommended Operating Conditions.....	5	<b>9 Device and Documentation Support</b> .....	36
6.5 Electrical Characteristics.....	6	9.1 Device Support.....	36
6.6 Timing Requirements.....	8	9.2 Documentation Support.....	36
6.7 Switching Characteristics.....	8	9.3 Receiving Notification of Documentation Updates...36	
6.8 Timing Diagram.....	9	9.4 Support Resources.....	36
6.9 Typical Characteristics.....	10	9.5 Trademarks.....	36
<b>7 Detailed Description</b> .....	13	9.6 Electrostatic Discharge Caution.....	36
7.1 Overview.....	13	9.7 Glossary.....	36
7.2 Functional Block Diagram.....	13		

## 4 Revision History

NOTE: Page numbers for previous revisions may differ from page numbers in the current version.

<b>Changes from Revision A (March 2019) to Revision B (July 2022)</b>	<b>Page</b>
• Updated the numbering format for tables, figures, and cross-references throughout the document .....	1
• Changed automotive-specific <i>Features</i> bullets.....	1
• Added <i>Functional Safety-Capable</i> bullets to <i>Features</i> section.....	1
• Changed <i>Excellent dc performance</i> sub-bullets: changed $\pm 1\text{-LSB typ DNL}$ to $\pm 0.6\text{-LSB DNL}$ and changed $\pm 1\text{-LSB typ INL}$ to $\pm 1\text{-LSB INL}$ .....	1
• Changed <i>Applications</i> section.....	1

<b>Changes from Revision * (January 2019) to Revision A (March 2019)</b>	<b>Page</b>
• Changed device status from Advance Information to Production Data.....	1

## 5 Pin Configuration and Functions

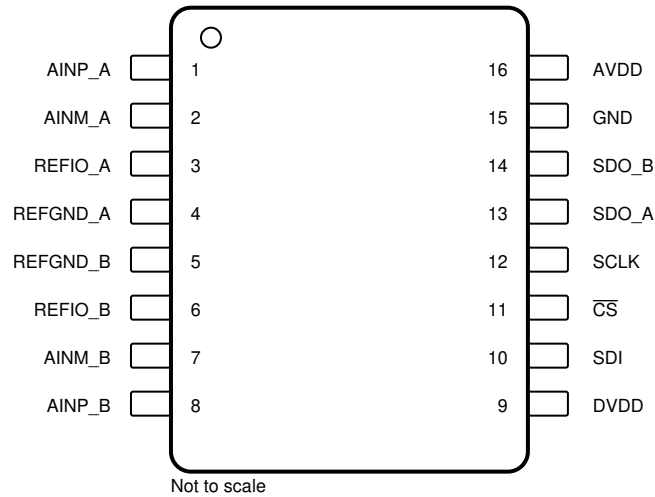

**Figure 5-1. PW Package, 16-Pin TSSOP (Top View)**

**Table 5-1. Pin Functions**

PIN		TYPE	DESCRIPTION
NAME	TSSOP		
AINM_A	2	Analog input	Negative analog input, channel A
AINM_B	7	Analog input	Negative analog input, channel B
AINP_A	1	Analog input	Positive analog input, channel A
AINP_B	8	Analog input	Positive analog input, channel B
AVDD	16	Supply	Supply voltage for ADC operation
$\overline{CS}$	11	Digital input	Chip-select signal; active low
DVDD	9	Digital I/O supply	Digital I/O supply
GND	15	Supply	Digital ground
REFGND_A	4	Supply	Reference ground potential A
REFGND_B	5	Supply	Reference ground potential B
REFIO_A	3	Analog input/output	Reference voltage input/output, channel A
REFIO_B	6	Analog input/output	Reference voltage input/output, channel B
SCLK	12	Digital input	Clock for serial communication
SDI	10	Digital input	Data input for serial communication
SDO_A	13	Digital output	Data output for serial communication, channel A and channel B
SDO_B	14	Digital output	Data output for serial communication, channel B

## 6 Specifications

### 6.1 Absolute Maximum Ratings

over operating ambient temperature range (unless otherwise noted)<sup>(1)</sup>

	MIN	MAX	UNIT
AVDD to REFGND_x <sup>(2)</sup> or GND	-0.3	6	V
DVDD to GND	-0.3	6	V
Analog (AINP_x and AINM_x) <sup>(3)</sup> and reference input (REFIO_x) voltage with respect to REFGND_x	REFGND_x - 0.3	AVDD + 0.3	V
Digital input voltage with respect to GND	DVDD + 0.3	DVDD + 0.3	V
REFGND_x	GND - 0.3	GND + 0.3	V
Input current to any pin except supply pins	-10	10	mA
Junction temperature, T <sub>J</sub>	-40	125	°C
Storage temperature, T <sub>stg</sub>	-65	150	°C

- (1) Stresses beyond those listed under *Absolute Maximum Rating* may cause permanent damage to the device. These are stress ratings only, which do not imply functional operation of the device at these or any other conditions beyond those indicated under *Recommended Operating Condition*. Exposure to absolute-maximum-rated conditions for extended periods may affect device reliability.
- (2) REFGND\_x refers to REFGND\_A and REFGND\_B. REFIO\_x refers to REFIO\_A and REFIO\_B.
- (3) AINP\_x refers AINP\_A and AINP\_B. AINM\_x refers to AINM\_A and AINM\_B.

### 6.2 ESD Ratings

			VALUE	UNIT	
V <sub>(ESD)</sub>	Electrostatic discharge	Human-body model (HBM), per AEC Q100-002 <sup>(1)</sup>	±2000	V	
		Charged-device model (CDM), per AEC Q100-001, level C4B	Corner pins (1,8,9 and 16)		±750
			All other pins		±500

- (1) AEC Q100-002 indicates that HBM stressing shall be in accordance with the ANSI/ESDA/JEDEC JS-001 specification.

### 6.3 Thermal Information

THERMAL METRIC <sup>(1)</sup>		ADS8353-Q1	UNIT
		PW (TSSOP)	
		16 PINS	
R <sub>θJA</sub>	Junction-to-ambient thermal resistance	99	°C/W
R <sub>θJC(top)</sub>	Junction-to-case (top) thermal resistance	29.6	°C/W
R <sub>θJB</sub>	Junction-to-board thermal resistance	45	°C/W
Ψ <sub>JT</sub>	Junction-to-top characterization parameter	1.4	°C/W
Υ <sub>JB</sub>	Junction-to-board characterization parameter	44.5	°C/W
R <sub>θJC(bot)</sub>	Junction-to-case (bottom) thermal resistance	N/A	°C/W

- (1) For more information about traditional and new thermal metrics, see the [Semiconductor and IC Package Thermal Metrics](#) application report.

## 6.4 Recommended Operating Conditions

over operating free-air temperature range (unless otherwise noted)

PARAMETER		TEST CONDITIONS	MIN	TYP	MAX	UNIT
<b>POWER SUPPLY</b>						
AVDD	Analog supply voltage (AVDD to AGND)	V <sub>REF</sub> range, internal reference	4.5	5	5.5	V
		V <sub>REF</sub> range, external reference V <sub>EXT_REF</sub> < 4.5 V	4.5	5	5.5	
		V <sub>REF</sub> range, external reference V <sub>EXT_REF</sub> > 4.5 V	V <sub>EXT_REF</sub>	5	5.5	
		2x V <sub>REF</sub> range, internal reference	5	5	5.5	
		2x V <sub>REF</sub> range, external reference	2 x V <sub>EXT_REF</sub>	5	5.5	
DVDD	Digital supply voltage		1.65	3.3	5.5	V
<b>ANALOG INPUTS (Single-Ended Configuration)</b>						
FSR	Full-scale input range (AINP_x to AINM_x) <sup>(1)</sup>	V <sub>REF</sub> range, single-ended input, AINM_x = GND	0		V <sub>REF</sub>	V
		2x V <sub>REF</sub> range, single-ended input, AINM_x = GND	0		2 x V <sub>REF</sub>	
V <sub>INP</sub>	Absolute input voltage (AINP_x to REFGND_x) <sup>(2)</sup>	V <sub>REF</sub> range	0		V <sub>REF</sub>	V
		2x V <sub>REF</sub> range, AVDD ≥ 2x V <sub>REF</sub>	0		2 x V <sub>REF</sub>	
V <sub>INM</sub>	Absolute input voltage (AINM_x to REFGND_x)	V <sub>REF</sub> range, single-ended input	-0.1		0.1	V
		2x V <sub>REF</sub> range, single-ended input, AVDD ≥ 2 x V <sub>REF</sub>	-0.1		0.1	
<b>ANALOG INPUTS (Pseudo-Differential Configuration)</b>						
FSR	Full-scale input range (AINP_x-AINM_x)	V <sub>REF</sub> range, pseudo-differential input, AINM_x = V <sub>REF</sub> /2	-V <sub>REF</sub> / 2		V <sub>REF</sub> / 2	V
		2x V <sub>REF</sub> range, pseudo-differential input, AINM_x = V <sub>REF</sub> , AVDD ≥ 2x V <sub>REF</sub>	-V <sub>REF</sub>		V <sub>REF</sub>	
V <sub>INP</sub>	Absolute input voltage (AINP_x to REFGND_x)	V <sub>REF</sub> range	0		V <sub>REF</sub>	V
		2x V <sub>REF</sub> range, AVDD ≥ 2x V <sub>REF</sub>	0		2 x V <sub>REF</sub>	
V <sub>INM</sub>	Absolute input voltage (AINM_x -REFGND_x)	V <sub>REF</sub> range, pseudo-differential input	V <sub>REF</sub> / 2 - 0.1		V <sub>REF</sub> / 2 + 0.1	V
		2x V <sub>REF</sub> range, single-ended input, AVDD ≥ 2x V <sub>REF</sub>	V <sub>REF</sub> - 0.1		V <sub>REF</sub> + 0.1	
<b>EXTERNAL REFERENCE INPUT</b>						
V <sub>REFIO</sub>	REFIO_x <sup>(3)</sup> input voltage	V <sub>REF</sub> range	2.4	2.5	AVDD	V
		2x V <sub>REF</sub> range	2.4	2.5	AVDD / 2	
<b>TEMPERATURE RANGE</b>						
T <sub>A</sub>	Ambient temperature		-40	25	125	°C

(1) AINP\_x refers to analog input pins AINP\_A and AINP\_B. AINM\_x refers to analog input pins AINM\_A and AINM\_B.

(2) REFGND\_x refers to reference ground pins REFGND\_A and REFGND\_B.

(3) REFIO\_x refers to voltage reference inputs REFIO\_A and REFIO\_B.

## 6.5 Electrical Characteristics

at AVDD = 5 V, DVDD = 3.3 V,  $V_{REF\_A} = V_{REF\_B} = V_{REF} = 2.5$  V (internal), and  $f_{DATA} = 600$  kSPS (unless otherwise noted); minimum and maximum values at  $T_A = -40^{\circ}\text{C}$  to  $125^{\circ}\text{C}$ ; typical values are at  $T_A = 25^{\circ}\text{C}$

PARAMETER		TEST CONDITIONS	MIN	TYP	MAX	UNIT
<b>ANALOG INPUTS</b>						
$C_i$	Input capacitance	In sample mode		40		pF
		In hold mode		4		
$I_{lkg}$	Input leakage current			0.1		$\mu\text{A}$
<b>RESOLUTION</b>						
	Resolution		16			Bits
<b>DC ACCURACY</b>						
NMC	No missing codes			16		Bits
INL	Integral nonlinearity		-4	$\pm 1$	4	LSB
DNL	Differential nonlinearity			$\pm 0.6$		LSB
$E_{IO}$	Input offset error		-1	$\pm 0.5$	1	mV
	$E_{IO}$ match	ADC_A to ADC_B	-1	$\pm 0.5$	1	mV
$dE_{IO}/dT$	Input offset thermal drift			1		$\mu\text{V}/^{\circ}\text{C}$
$E_G$	Gain error	Referenced to the voltage at REFIO_x	-0.1	$\pm 0.05$	0.1	%FS
	$E_G$ match	ADC_A to ADC_B	-0.1	$\pm 0.05$	0.1	%FS
$dE_G/dT$	Gain error thermal drift	Referenced to the voltage at REFIO_x		1		ppm/ $^{\circ}\text{C}$
<b>AC ACCURACY</b>						
SINAD	Signal-to-noise + distortion	$V_{REF} = 2.5$ V, $V_{REF}$ input range	80.2	83		dB
		$V_{REF} = 2.5$ V, $2x V_{REF}$ input range		83.9		
		$V_{REF} = 5$ V, $V_{REF}$ input range		88.7		
SNR	Signal-to-noise ratio	$V_{REF} = 2.5$ V, $V_{REF}$ input range	80.5	83		dB
		$V_{REF} = 2.5$ V, $2x V_{REF}$ input range		84		
		$V_{REF} = 5$ V, $V_{REF}$ input range		89		
THD	Total harmonic distortion	$V_{REF} = 2.5$ V, $V_{REF}$ input range		-100		dB
		$V_{REF} = 2.5$ V, $2x V_{REF}$ input range		-100		
		$V_{REF} = 5$ V, $V_{REF}$ input range		-100		
SFDR	Spurious-free dynamic range	$V_{REF} = 2.5$ V, $V_{REF}$ input range		105		dB
		$V_{REF} = 2.5$ V, $2x V_{REF}$ input range		105		
		$V_{REF} = 5$ V, $V_{REF}$ input range		105		
<b>INTERNAL VOLTAGE REFERENCE</b>						
$V_{REFOUT}$	Reference output voltage	REFDAC_x = 1FFh (default) at $25^{\circ}\text{C}$	2.495	2.5	2.505	V
$V_{REF-match}$	$V_{REF\_A}$ to $V_{REF\_B}$ matching	REFDAC_x = 1FFh (default) at $25^{\circ}\text{C}$		$\pm 1$		mV
REFDAC_x resolution <sup>(1)</sup>				1.1		mV
$dV_{REFOUT}/dT$	Reference voltage temperature drift	REFDAC_x = 1FFh (default) at $25^{\circ}\text{C}$		$\pm 10$		ppm/ $^{\circ}\text{C}$
$dV_{REFOUT}/dt$	Long-term stability	1000 hours		150		ppm
$R_O$	Internal reference output impedance			1		$\Omega$
$I_{REFOUT}$	Reference output dc current			2		mA
$C_{REFOUT}$	Reference output capacitor			10		$\mu\text{F}$
$t_{REFON}$	Reference output settling time			8		ms
<b>VOLTAGE REFERENCE INPUT</b>						
$I_{REF}$	Average reference input current	Per ADC		300		$\mu\text{A}$

## 6.5 Electrical Characteristics (continued)

at AVDD = 5 V, DVDD = 3.3 V, V<sub>REF\_A</sub> = V<sub>REF\_B</sub> = V<sub>REF</sub> = 2.5 V (internal), and f<sub>DATA</sub> = 600 kSPS (unless otherwise noted); minimum and maximum values at T<sub>A</sub> = –40°C to 125°C; typical values are at T<sub>A</sub> = 25°C

PARAMETER		TEST CONDITIONS	MIN	TYP	MAX	UNIT
C <sub>REF</sub>	External ceramic reference capacitor			10		μF
I <sub>lkg(dc)</sub>	DC leakage current			±0.1		μA
<b>SAMPLING DYNAMICS</b>						
t <sub>A</sub>	Aperture delay			8		ns
	t <sub>A</sub> match	ADC_A to ADC_B		40		ps
t <sub>AJIT</sub>	Aperture jitter			50		ps
<b>DIGITAL INPUTS</b>						
V <sub>IH</sub>	High-level input voltage	DVDD > 2.3 V	0.7 DVDD		DVDD + 0.3	V
		DVDD ≤ 2.3 V	0.8 DVDD		DVDD + 0.3	
V <sub>IL</sub>	Low-level input voltage	DVDD > 2.3 V	–0.3		0.3 DVDD	V
		DVDD ≤ 2.3 V	–0.3		0.2 DVDD	
	Input current			±10		nA
<b>DIGITAL OUTPUTS</b>						
V <sub>OH</sub>	High-level output voltage	I <sub>OH</sub> = 500-μA source	0.8 DVDD		DVDD	V
V <sub>OL</sub>	Low-level output voltage	I <sub>OL</sub> = 500-μA sink	0		0.2 DVDD	V
<b>POWER SUPPLY</b>						
AIDD	Analog supply current	AVDD = 5 V, fastest throughput internal reference		8.5	10	mA
		AVDD = 5 V, fastest throughput external reference <sup>(2)</sup>		7.5	3.6	
		AVDD = 5V, no conversion internal reference		5.5	7	
		AVDD = 5 V, no conversion external reference <sup>(2)</sup>		4.5		
		AVDD = 5 V, STANDBY mode internal reference		2.5		
		AVDD = 5 V, STANDBY mode external reference <sup>(2)</sup>		1		
		Power-down mode		10	50	μA
DIDD	Digital supply current	DVDD = 3.3 V, C <sub>load</sub> = 10 pF, fastest throughput		0.5		mA
		DVDD = 5 V, C <sub>load</sub> = 10 pF, fastest throughput		1		
P <sub>D</sub>	Power dissipation (normal operation)	AVDD = 5 V, fastest throughput, internal reference		42.5	50	mW

(1) Refer to the Reference section for more details.

(2) With internal reference powered down, CFR.B6 = 0.

## 6.6 Timing Requirements

at AVDD = 5 V, DVDD = 1.65 V to 5.5 V, and maximum throughput (unless otherwise noted); minimum and maximum values at T<sub>A</sub> = -40°C to +125°C; typical values at T<sub>A</sub> = 25°C.

		MIN	NOM	MAX	UNIT
t <sub>PH_CK</sub>	CLOCK high time	0.4		0.6	t <sub>CLK</sub>
t <sub>PL_CK</sub>	CLOCK low time	0.4		0.6	t <sub>CLK</sub>
f <sub>CLK</sub>	CLOCK frequency			20	MHz
t <sub>ACQ</sub>	Acquisition time	32-clock, dual SDO mode		33 x t <sub>CLK</sub> - t <sub>CONV</sub>	ns
		32-clock, single SDO mode		49 x t <sub>CLK</sub> - t <sub>CONV</sub>	
t <sub>CONV</sub>	Conversion time			730	ns
t <sub>PH_CS</sub>	$\overline{CS}$ high time	40			ns
t <sub>PH_CS_SHRT</sub>	$\overline{CS}$ high time after frame abort	150			ns
t <sub>SU_CSCK</sub>	Setup time: $\overline{CS}$ falling edge to SCLK falling edge	15			ns
t <sub>D_CKCS</sub>	Delay time: Last SCLK falling edge to $\overline{CS}$ rising edge	15			ns
t <sub>SU_CKDI</sub>	Setup time: DIN data valid to SCLK falling edge	5			ns
t <sub>HT_CKDI</sub>	Hold time: SCLK falling edge to (previous) data valid on DIN	5			ns
t <sub>PU_STDBY</sub>	Power-up time from STANDBY mode	1			μs
t <sub>PU_SPD</sub>	Power-up time from SPD mode	With internal reference		3	ms
		With external reference		1	

## 6.7 Switching Characteristics

at AVDD = 5 V, DVDD = 1.65 V to 5.5 V, and maximum throughput (unless otherwise noted); minimum and maximum values at T<sub>A</sub> = -40°C to +125°C; typical values at T<sub>A</sub> = 25°C.

PARAMETER		TEST CONDITIONS	MIN	TYP	MAX	UNIT
t <sub>THROUGHPUT</sub>	Throughput time		1.666			μs
f <sub>THROUGHPUT</sub>	Throughput				600	kSPS
t <sub>DV_CSDO</sub>	Delay time: $\overline{CS}$ falling edge to data enable				12	ns
t <sub>DZ_CSDO</sub>	Delay time: $\overline{CS}$ rising edge to data going to 3-state				12	ns
t <sub>D_CKDO</sub>	Delay time: SCLK falling edge to next data valid				20	ns



## 6.8 Timing Diagram

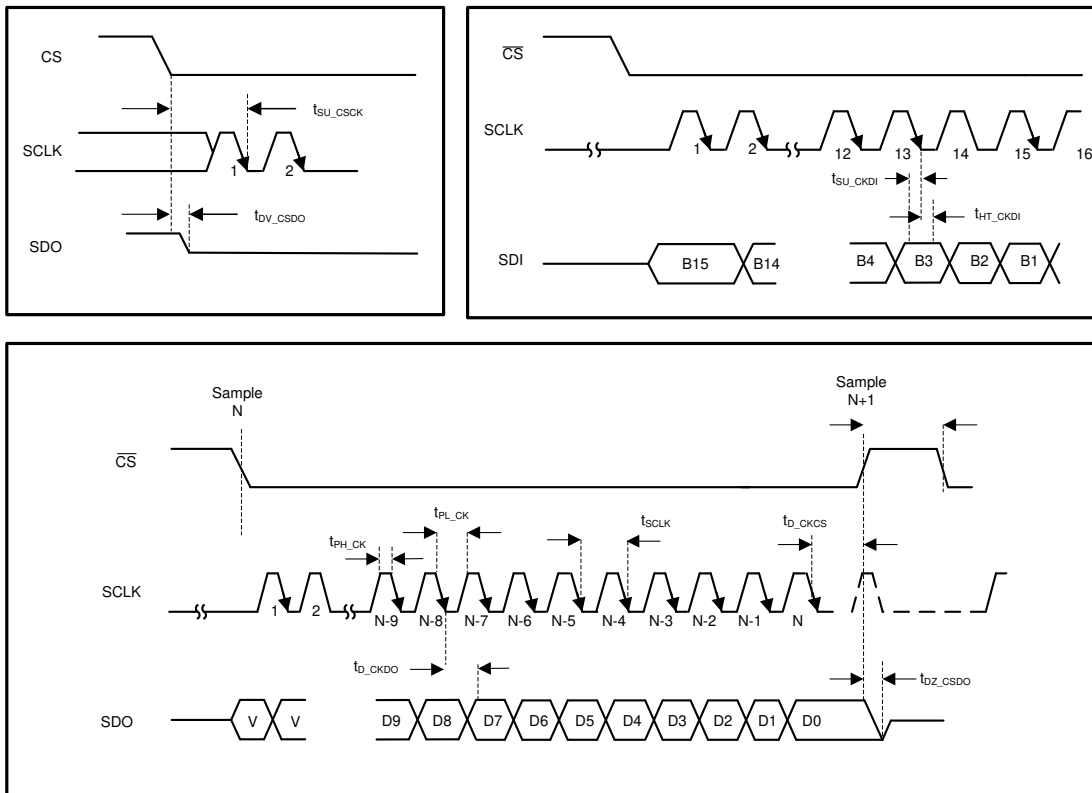

**Figure 6-1. Serial Interface Timing Diagram**

## 6.9 Typical Characteristics

at  $T_A = 25^\circ\text{C}$ ,  $AV_{DD} = 5\text{ V}$ ,  $DV_{DD} = 3.3\text{ V}$ ,  $V_{REF} = 2.5\text{ V}$  (internal), and  $f_{DATA} = 600\text{ kSPS}$  (unless otherwise noted)

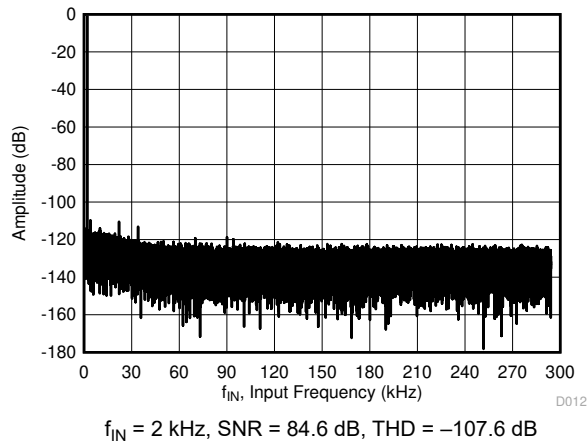

Figure 6-2. Typical FFT

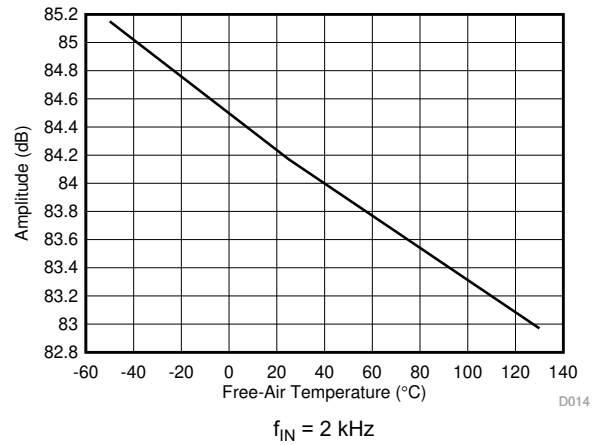

Figure 6-3. SNR vs Temperature

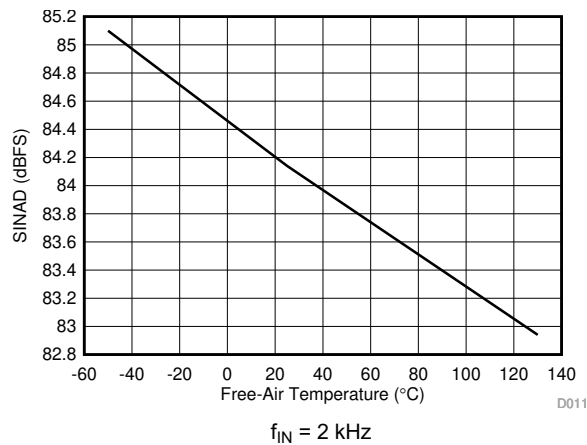

Figure 6-4. SINAD vs Temperature

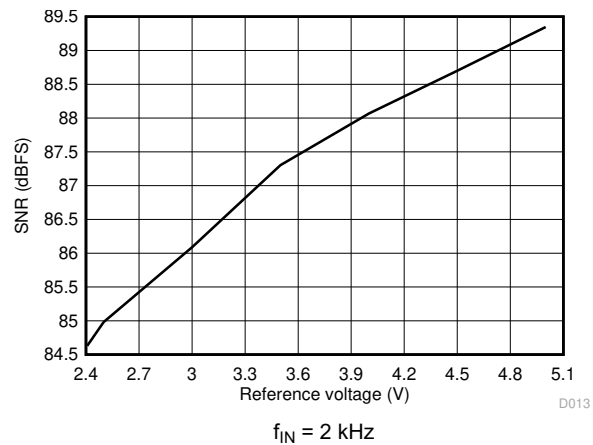

Figure 6-5. SNR vs Reference Voltage

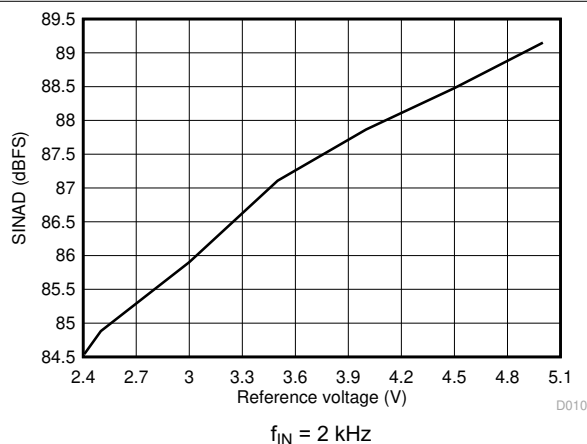

Figure 6-6. SINAD vs Reference Voltage

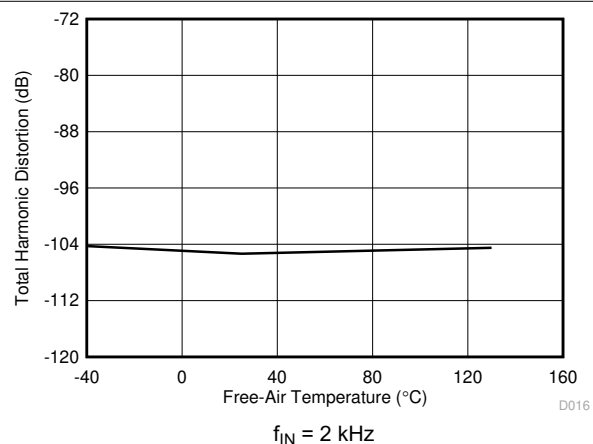

Figure 6-7. THD vs Temperature

### 6.9 Typical Characteristics (continued)

at  $T_A = 25^\circ\text{C}$ ,  $AVDD = 5\text{ V}$ ,  $DVDD = 3.3\text{ V}$ ,  $V_{REF} = 2.5\text{ V}$  (internal), and  $f_{DATA} = 600\text{ kSPS}$  (unless otherwise noted)

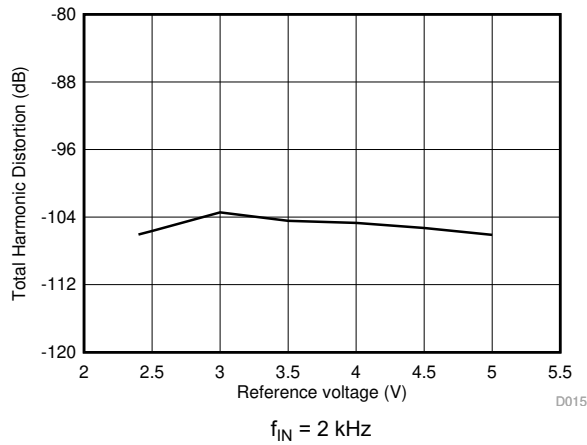

Figure 6-8. THD vs Reference Voltage

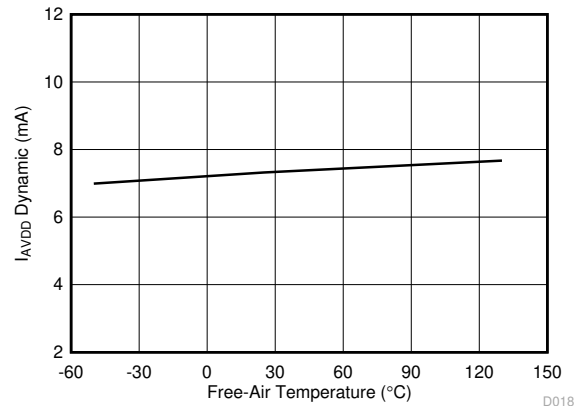

Figure 6-9. Analog Supply Current vs Temperature

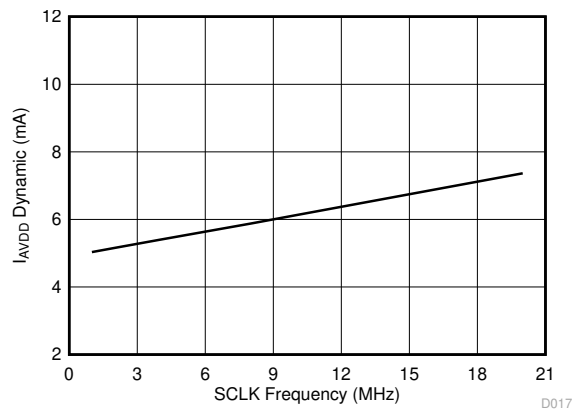
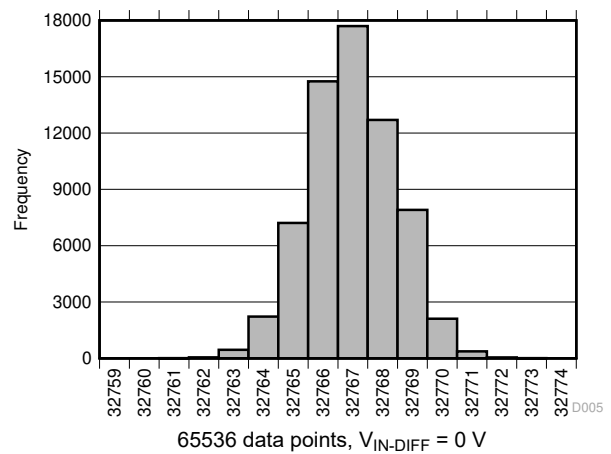

Figure 6-10. Analog Supply Current vs SCLK Frequency



65536 data points,  $V_{IN-DIFF} = 0\text{ V}$

Figure 6-11. DC Histogram

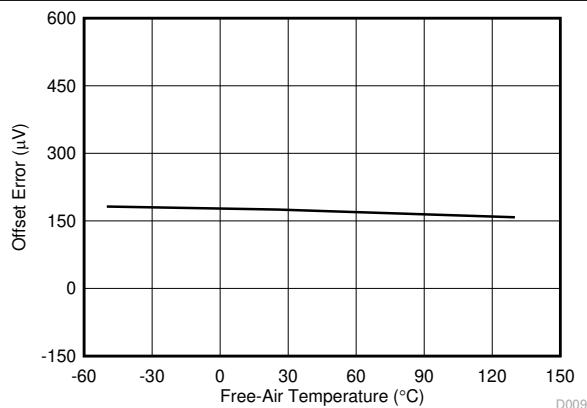

Figure 6-12. Offset Error vs Temperature

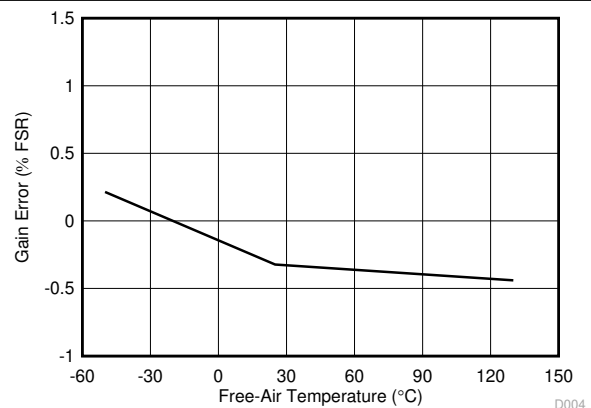

Figure 6-13. Gain Error vs Temperature

### 6.9 Typical Characteristics (continued)

at  $T_A = 25^\circ\text{C}$ ,  $AV_{DD} = 5\text{ V}$ ,  $DV_{DD} = 3.3\text{ V}$ ,  $V_{REF} = 2.5\text{ V}$  (internal), and  $f_{DATA} = 600\text{ kSPS}$  (unless otherwise noted)

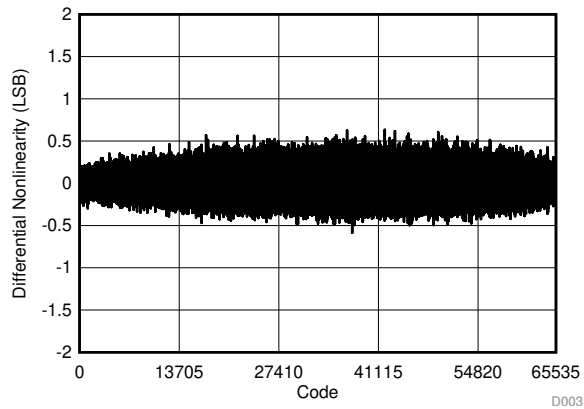

Figure 6-14. Typical DNL

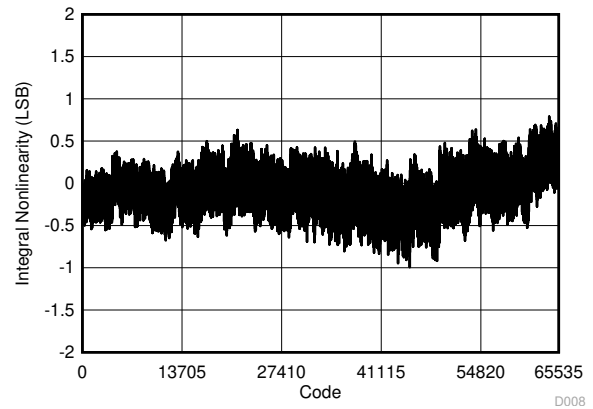

Figure 6-15. Typical INL

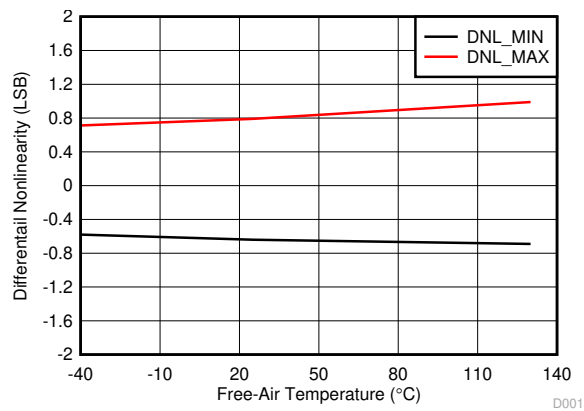

Figure 6-16. DNL vs Temperature

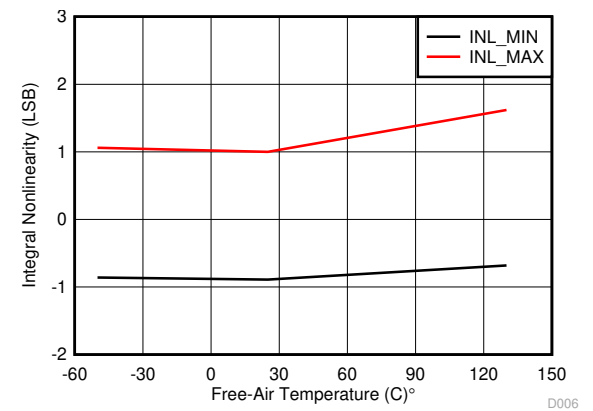

Figure 6-17. INL vs Temperature

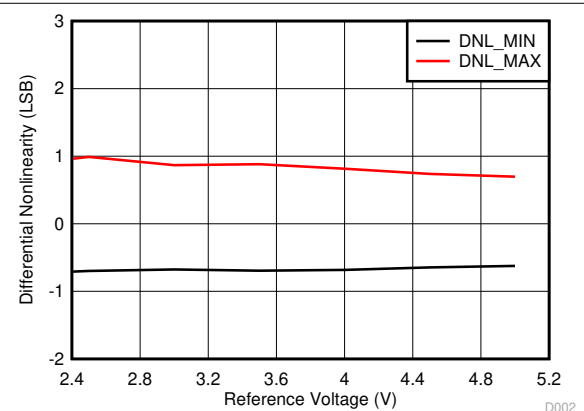

Figure 6-18. DNL vs Reference Voltage

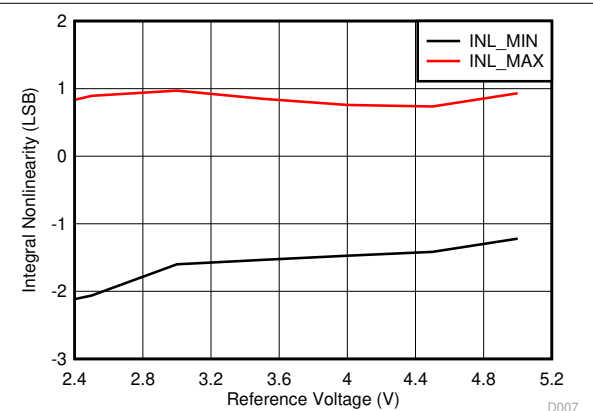

Figure 6-19. INL vs Reference Voltage

## 7 Detailed Description

### 7.1 Overview

The ADS8353-Q1 is a 16-bit, dual-channel, high-speed, simultaneous-sampling, analog-to-digital converter (ADC). The ADS8353-Q1 supports single-ended and pseudo-differential input signals. The device provides a simple, serial interface to the host controller and operates over a wide range of analog and digital power supplies.

The device has two independently programmable internal references to achieve system-level gain error correction. The [Functional Block Diagram](#) section provides a functional block diagram of the device.

### 7.2 Functional Block Diagram

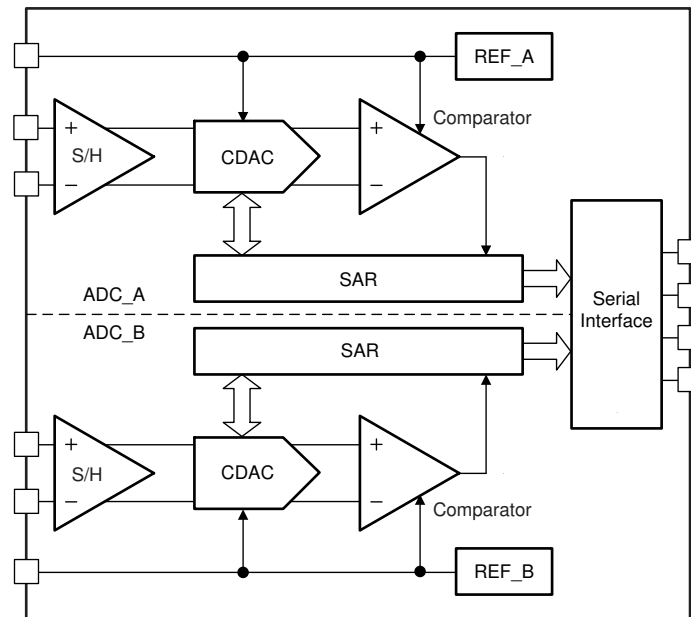

## 7.3 Feature Description

### 7.3.1 Reference

The device has two simultaneous sampling ADCs (ADC\_A and ADC\_B). ADC\_A and ADC\_B operate with reference voltages present on the REFIO\_A and REFIO\_B pins, respectively. Decouple the REFIO\_A and REFIO\_B pins with the REFGND\_A and REFGND\_B pins, respectively, with 10- $\mu$ F decoupling capacitors.

Figure 7-1 shows that the device supports operation either with an internal or external reference source. The reference voltage source is determined by setting bit 6 of the configuration register (CFR.B6). This bit is common to ADC\_A and ADC\_B.

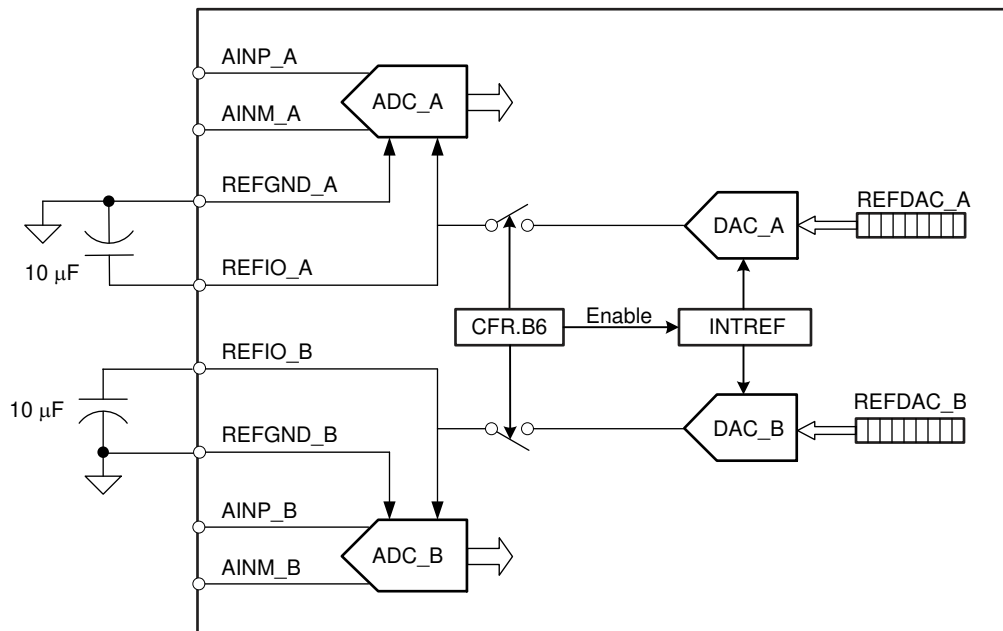

**Figure 7-1. Reference Configurations and Connections**

When CFR.B6 is 0, the device shuts down the internal reference source (INTREF) and ADC\_A and ADC\_B operate on external reference voltages provided by the user on the REFIO\_A and REFIO\_B pins, respectively.

When CFR.B6 is 1, the device operates with the internal reference source (INTREF) connected to REFIO\_A and REFIO\_B via DAC\_A and DAC\_B, respectively. In this configuration,  $V_{REF\_A}$  and  $V_{REF\_B}$  can be changed independently by writing to the respective user-programmable registers, REFDAC\_A and REFDAC\_B, respectively. See the [Register Maps](#) section for more details.

### 7.3.2 Analog Inputs

The ADS8353-Q1 supports single-ended or pseudo-differential analog inputs on both ADC channels. These inputs are sampled and converted simultaneously by the two ADCs, ADC\_A and ADC\_B. ADC\_A samples and converts ( $V_{AINP\_A} - V_{AINM\_A}$ ), and ADC\_B samples and converts ( $V_{AINP\_B} - V_{AINM\_B}$ ).

Figure 7-2a and Figure 7-2b show equivalent circuits for the ADC\_A and ADC\_B analog input pins, respectively. Series resistance,  $R_S$ , represents the on-state sampling switch resistance (typically 50  $\Omega$ ) and  $C_{SAMPLE}$  is the device sampling capacitor (typically 40 pF).

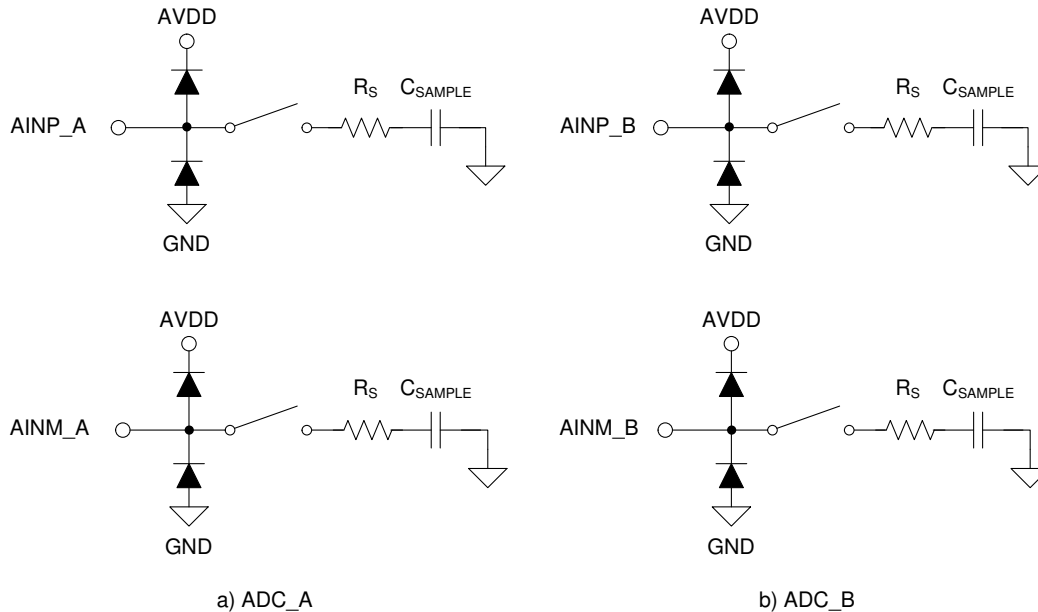

Figure 7-2. Equivalent Circuit for the Analog Input Pins

#### 7.3.2.1 Analog Input: Full-Scale Range Selection

The full-scale range (FSR) supported at the analog inputs of the device is programmable with bit B9 of the configuration register (CFR.B9). This bit is common for both ADCs (ADC\_A and ADC\_B). Equation 1 and Equation 2 give the FSR:

$$\text{For CFR.B9} = 0, \text{FSR\_ADC\_A} = 0 \text{ to } V_{REF\_A} \text{ and } \text{FSR\_ADC\_B} = 0 \text{ to } V_{REF\_B} \quad (1)$$

$$\text{For CFR.B9} = 1, \text{FSR\_ADC\_A} = 0 \text{ to } 2 \times V_{REF\_A} \text{ and } \text{FSR\_ADC\_B} = 0 \text{ to } 2 \times V_{REF\_B} \quad (2)$$

where:

- $V_{REF\_A}$  and  $V_{REF\_B}$  are the reference voltages going to ADC\_A and ADC\_B, respectively (as described in the [Reference](#) section).

Therefore, with appropriate settings of the REFDAC\_A and REFDAC\_B registers, CFR.B7, and CFR.B9, the maximum dynamic range of the ADC can be used.

Make sure that the ADC analog supply (AVDD) is as in Equation 3 and Equation 4 when CFR.B9 is set to 1:

$$2 \times V_{REF\_A} \leq AVDD \leq AVDD(\text{max}) \quad (3)$$

$$2 \times V_{REF\_B} \leq AVDD \leq AVDD(\text{max}) \quad (4)$$

### 7.3.2.2 Analog Input: Single-Ended and Pseudo-Differential Configurations

The ADS8353-Q1 can support single-ended or pseudo-differential input configurations.

For supporting single-ended inputs, B7 in the configuration register (CFR.B7) must be set to 0 (CFR.B7 = 0) and AINM\_A and AINM\_B must be externally connected to GND.

For supporting pseudo-differential inputs, CFR.B7 must be set to 1 (CFR.B7 = 1) and AINM\_A and AINM\_B must be externally connected to FSR\_ADC\_A / 2 and FSR\_ADC\_B / 2, respectively. CFR.B7 is common to both ADCs.

The CFR.B9 and CFR.B7 settings can be combined as shown in [Table 7-1](#) to select the desired input configuration.

**Table 7-1. Input Configurations**

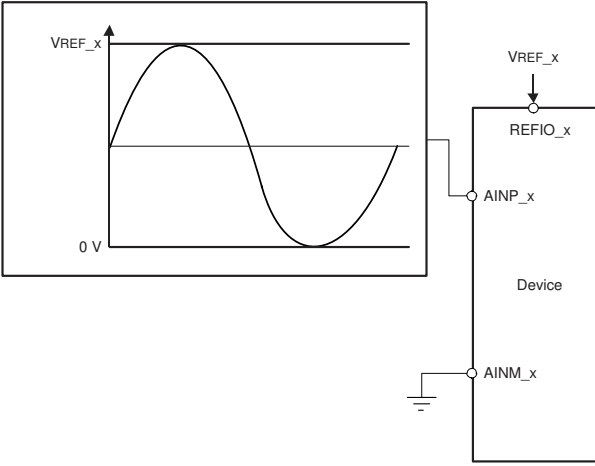
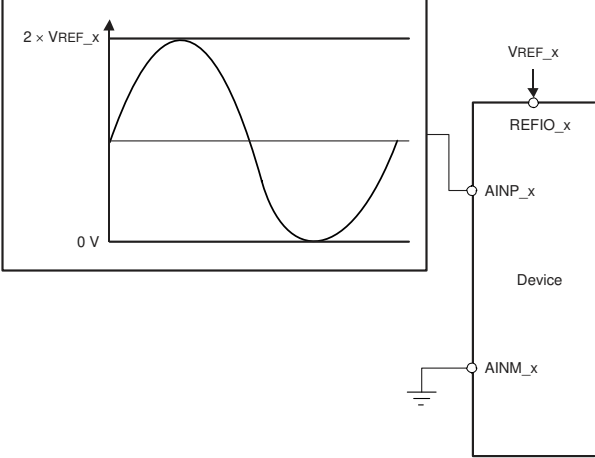
INPUT RANGE SELECTION	AINM SELECTION	CONNECTION DIAGRAM
<p>CFR.B9 = 0 (FSR_ADC_A = 0 to <math>V_{REF\_A}</math>) (FSR_ADC_B = 0 to <math>V_{REF\_B}</math>)</p>	<p>CFR.B7 = 0 (AINM_A = GND) (AINM_B = GND)</p>	
<p>CFR.B9 = 1 (FSR_ADC_A = 0 to <math>2 \times V_{REF\_A}</math>) (FSR_ADC_B = 0 to <math>2 \times V_{REF\_B}</math>)</p>	<p>CFR.B7 = 0 (AINM_A = GND) (AINM_B = GND)</p>	

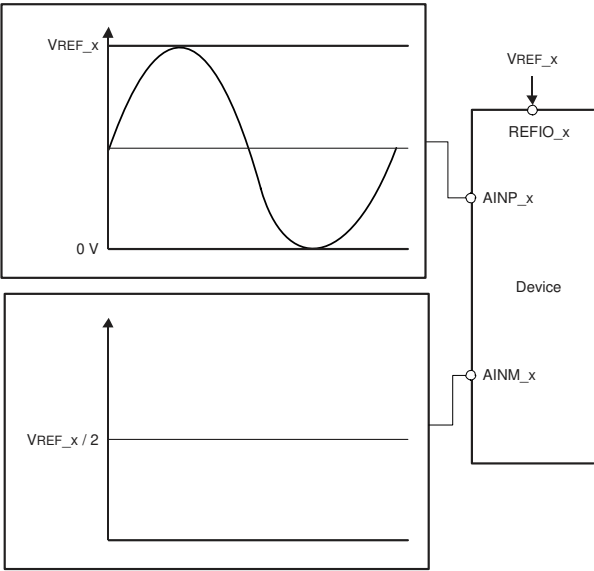
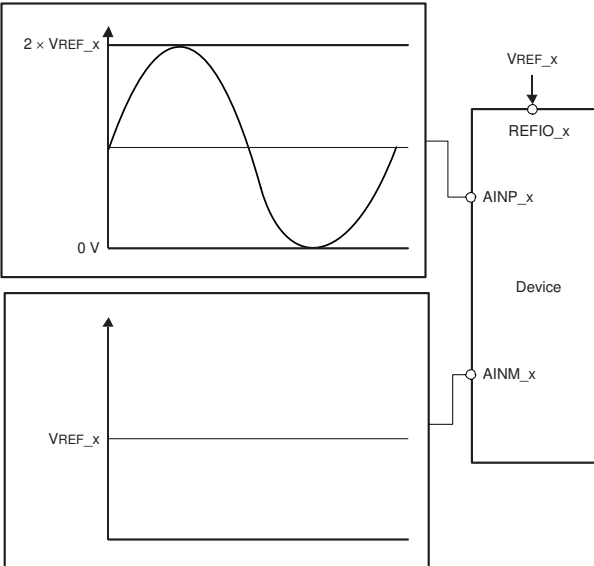

**Table 7-1. Input Configurations (continued)**

INPUT RANGE SELECTION	AINM SELECTION	CONNECTION DIAGRAM
<p>           CFR.B9 = 0            (FSR_ADC_A = <math>V_{REF\_A}</math>)            (FSR_ADC_B = <math>V_{REF\_B}</math>)         </p>	<p>           CFR.B7 = 1            (AINM_A = <math>V_{REF\_A}/2</math>)            (AINM_B = <math>V_{REF\_B}/2</math>)         </p>	
<p>           CFR.B9 = 1            (FSR_ADC_A = <math>2 \times V_{REF\_A}</math>)            (FSR_ADC_B = <math>2 \times V_{REF\_B}</math>)         </p>	<p>           CFR.B7 = 1            (AINM_A = <math>V_{REF\_A}</math>)            (AINM_B = <math>V_{REF\_B}</math>)         </p>	

### 7.3.3 Transfer Function

The device supports two input configurations:

1. Single-ended inputs, CFR.B7 = 0 (default), or
2. Pseudo-differential inputs, CFR.B7 = 1

The device also supports two output data formats:

1. Straight binary output, CFR.B4 = 0 (default), or
2. Two's compliment output, CFR.B4 = 1

Equation 5 calculates the device resolution:

$$1 \text{ LSB} = (\text{FSR\_ADC\_x}) / (2^N) \tag{5}$$

where:

- N = 16
- FSR\_ADC\_x = the full-scale input range of the ADC (see the *Analog Inputs* section for more details)

Table 7-2 and Table 7-3 show the different input voltages and the corresponding output codes from the device.

**Table 7-2. Transfer Characteristics for Straight Binary Output (CFR.B4 = 0, Default)**

INPUT CONFIGURATION	INPUT VOLTAGE			OUTPUT CODE (Hex)	
				STRAIGHT BINARY (CFR.B4 = 0, Default)	
	AINP_x	AINM_x	AINP_x - AINM_x	CODE	ADS8353-Q1
Single-ended (CFR.B7 = 0, default)	≤ 1 LSB	0	≤ 1 LSB	ZC	0000
	FSR_ADC_x / 2		FSR_ADC_x / 2	MC	7FFF
	≥ FSR_ADC_x - 1 LSB		≥ FSR_ADC_x - 1 LSB	FSC	FFFF
Pseudo-differential (CFR.B7 = 1)	≤ 1 LSB	FSR_ADC_x / 2	≤ -FSR_ADC_x / 2 + 1 LSB	ZC	0000
	FSR_ADC_x / 2		0	MC	7FFF
	≥ FSR_ADC_x - 1 LSB		≥ FSR_ADC_x / 2 - 1 LSB	FSC	FFFF

**Table 7-3. Transfer Characteristics for Two's Compliment Output (CFR.B4 = 1)**

INPUT CONFIGURATION	INPUT VOLTAGE			OUTPUT CODE (Hex)	
				TWO'S COMPLIMENT (CFR.B4 = 1, Default)	
	AINP_x	AINM_x	AINP_x - AINM_x	CODE	ADS8353-Q1
Single-ended (CFR.B7 = 0, default)	≤ 1 LSB	0	≤ 1 LSB	NFSC	8000
	FSR_ADC_x / 2		FSR_ADC_x / 2	MC	0000
	≥ FSR_ADC_x - 1 LSB		≥ FSR_ADC_x - 1 LSB	PFSC	7FFF
Pseudo-differential (CFR.B7 = 1)	≤ 1 LSB	FSR_ADC_x / 2	≤ -FSR_ADC_x / 2 + 1 LSB	NFSC	8000
	FSR_ADC_x / 2		0	MC	0000
	≥ FSR_ADC_x - 1 LSB		≥ FSR_ADC_x / 2 - 1 LSB	PFSC	7FFF

Figure 7-3 shows the ideal device transfer characteristics for the single-ended analog input.

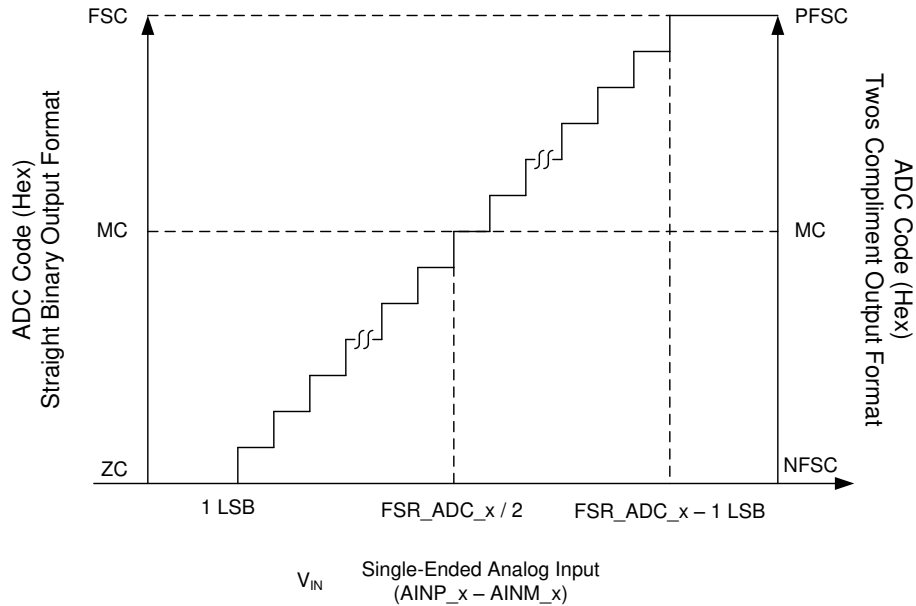

**Figure 7-3. Ideal Transfer Characteristics for a Single-Ended Analog Input**

Figure 7-4 shows the ideal device transfer characteristics for the pseudo-differential analog input.

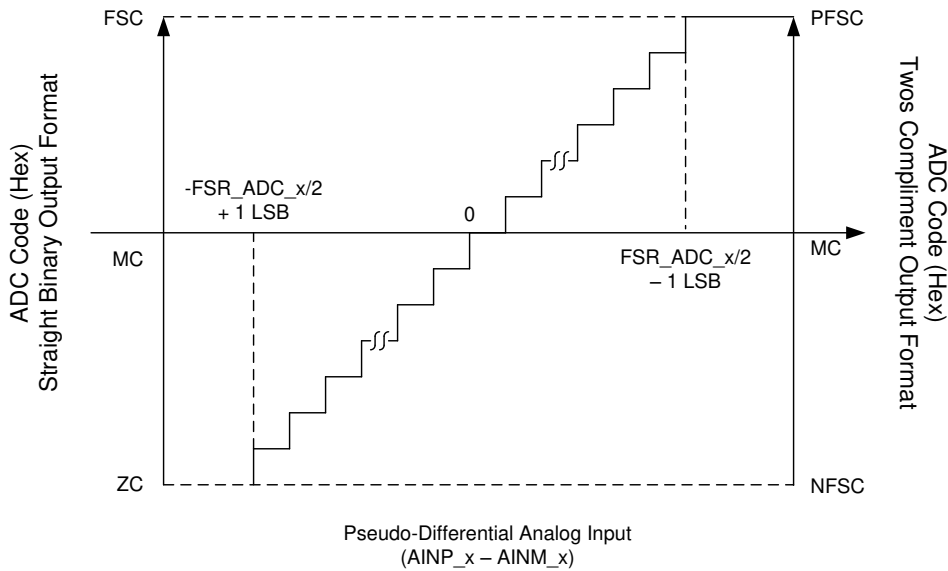

**Figure 7-4. Ideal Transfer Characteristics for a Pseudo-Differential Analog Input**

## 7.4 Device Functional Modes

The device provides three user-programmable registers: the configuration register (CFR), the REFDAC\_A register, and the REFDAC\_B register. These registers support write (see the [Write to User-Programmable Registers](#) section) and readback (see the [Reading User-Programmable Registers](#) section) operations and allow the ADC behavior to be customized for specific application requirements.

The device supports two interface modes (see the [Conversion Data Read](#) section), two low-power modes (see the [Low-Power Modes](#) section), and a short-cycling or reconversion feature (see the [Frame Abort, Reconversion, or Short-Cycling](#) section).

## 7.5 Programming

### 7.5.1 Serial Interface

The device uses the serial clock (SCLK) for synchronizing data transfers in and out of the device.

The  $\overline{CS}$  signal defines one conversion and serial transfer frame. A frame starts with a  $\overline{CS}$  falling edge and ends with a  $\overline{CS}$  rising edge. Between the start and end of the frame, a minimum of  $N$  SCLK falling edges must be provided to validate the read or write operation. As shown in [Table 7-4](#),  $N$  depends upon the interface mode used to read the conversion result. When  $N$  SCLK falling edges are provided, the write operation attempted in the frame is validated and the internal user-programmable registers are updated on the subsequent  $\overline{CS}$  rising edge. This  $\overline{CS}$  rising edge also ends the frame.

**Table 7-4. SCLK Falling Edges for a Valid Write Operation**

INTERFACE MODE	MINIMUM SCLK FALLING EDGES REQUIRED TO VALIDATE WRITE OPERATION $N$
32-CLK, dual-SDO mode (default); see the <a href="#">32-CLK, Dual-SDO Mode (CFR.B11 = 0, CFR.B10 = 0, Default)</a> section	32
32-CLK, single-SDO mode; see the <a href="#">32-CLK, Single-SDO Mode (CFR.B11 = 0, CFR.B10 = 1)</a> section	48

If  $\overline{CS}$  is brought high before providing  $N$  SCLK falling edges, the write operation attempted in the frame is not valid. See the [Frame Abort, Reconversion, or Short-Cycling](#) section for more details.

### 7.5.2 Write to User-Programmable Registers

The device features three user-programmable registers: the configuration register (CFR), the REFDAC\_A register, and the REFDAC\_B register. These registers can be written with the device SDI pin. The first 16 bits of data on SDI are latched into the device on the first 16 SCLK falling edges. However, the new configuration takes effect only when the read or write operation is validated. If these registers are not required to update, SDI must remain low during the respective frames.

The first four SDI data bits (B[15:12]) determine what operation is performed (that is, either a read or write operation or no operation), which register address the operation uses, and the function of the next 12 SDI data bits (B[11:0]). [Table 7-5](#) lists the various combinations supported for B[15:12].

**Table 7-5. Data Write Operation**

B15	B14	B13	B12	OPERATION	FUNCTION OF BITS B[11:0]
0	0	0	0	No operation is performed	These bits are ignored
0	0	0	1	REFDAC_A read	000h; see the <a href="#">Reading User-Programmable Registers</a> section
0	0	1	0	REFDAC_B read	000h; see the <a href="#">Reading User-Programmable Registers</a> section
0	0	1	1	CFR read	000h; see the <a href="#">Reading User-Programmable Registers</a> section
1	0	0	0	CFR write	See the <a href="#">CFR register</a>
1	0	0	1	REFDAC_A write	See the <a href="#">REFDAC register</a>
1	0	1	0	REFDAC_B write	See the <a href="#">REFDAC register</a>
1	0	1	1	No operation is performed	These bits are ignored
X	1	X	X	No operation is performed	These bits are ignored

### 7.5.3 Data Read Operation

The device supports two types of read operations: reading user-programmable registers and reading conversion results.

#### 7.5.3.1 Reading User-Programmable Registers

The device supports a readback option for all user-programmable registers: CFR, REFDAC\_A, and REFDAC\_B. Figure 7-5 shows a detailed timing diagram for this operation.

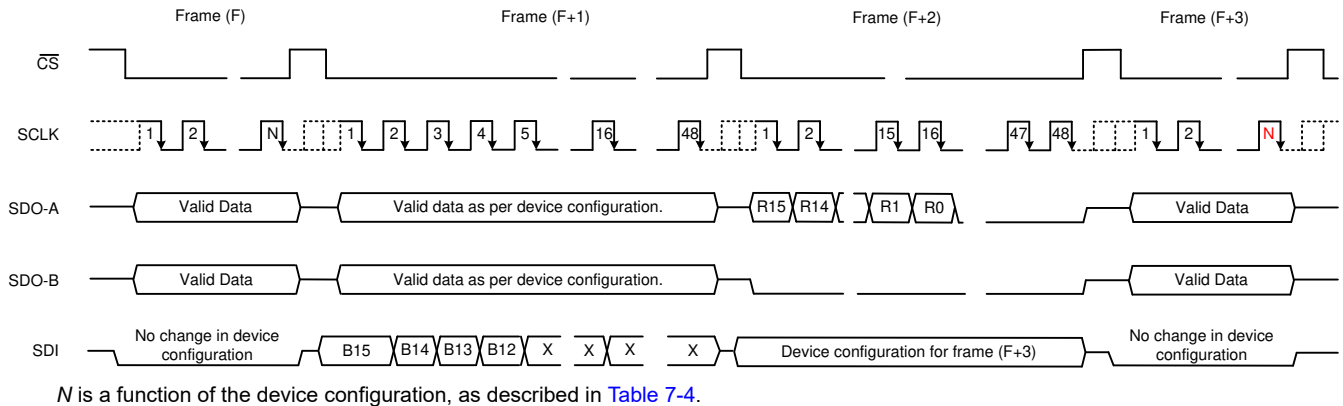

Figure 7-5. Register Readback Timing

To readback the user-programmable register settings, transmit the appropriate control word, as shown in Table 7-6, to the device during frame (F+1). Frame (F+1) must have at least 48 SCLK falling edges.

Table 7-6. Control Word to Readback User-Programmable Registers

USER-PROGRAMMABLE REGISTER	CONTROL WORD TO BE PROGRAMMED IN FRAME (F+1)	
	B[15:12] (Binary)	B[11:0] (Hex)
CFR	0011b	000h
REFDAC_A	0001b	000h
REFDAC_B	0010b	000h

Frame (F+2) must have at least 48 SCLK falling edges. During frame (F+2), SDO\_A outputs the contents of the selected user-programmable register on the first 16 SCLK falling edges (as shown in Table 7-7) and then outputs 0's for any subsequent SCLK falling edges. The SDO\_B pin outputs 0's for all SCLK falling edges.

Table 7-7. Register Data Read Back

USER-PROGRAMMABLE REGISTER	DATA READ ON SDO-A IN FRAME (F+2)									
	R15	R14	R13	R12	R11	—	R3	R2	R1	R0
CFR	0	0	1	1	CFG.B11	—	CFG.B3	CFG.B2	CFG.B1	CFG.B0
REFDAC_A	0	0	0	1	REFDAC_A.D8	—	REFDAC_A.D0	0	0	0
REFDAC_B	0	0	1	0	REFDAC_B.D8	—	REFDAC_B.D0	0	0	0

Register settings programmed during frame (F+2) determine the device configuration in frame (F+3).

### 7.5.3.2 Conversion Data Read

The device provides two different interface modes for reading the conversion result. These modes offer flexible hardware connections and firmware programming. Table 7-8 shows how to select one of the two interface modes.

**Table 7-8. Interface Mode Selection**

CFR.B11	CFR.B10	INTERFACE MODE	MINIMUM SCLK FALLING EDGES REQUIRED TO VALIDATE WRITE OPERATION N
0	0	32-CLK, dual-SDO mode (default)	32
0	1	32-CLK, single-SDO mode	48

In the 32-CLK interface modes, the device uses an internal clock to convert the sampled analog signal. The conversion is completed during the first 16 periods of SCLK and the conversion result can be read on the subsequent SCLK falling edges.

The following sections detail the various interface modes supported by the device.

#### 7.5.3.2.1 32-CLK, Dual-SDO Mode (CFR.B11 = 0, CFR.B10 = 0, Default)

The 32-CLK, dual-SDO mode is the default mode supported by the device. This mode can also be selected by writing CFR.B11 = 0 and CFR.B10 = 0.

In this mode, the SDO\_A pin outputs the ADC\_A conversion result and the SDO\_B pin outputs the ADC\_B conversion result. Figure 7-6 shows a detailed timing diagram for this mode.

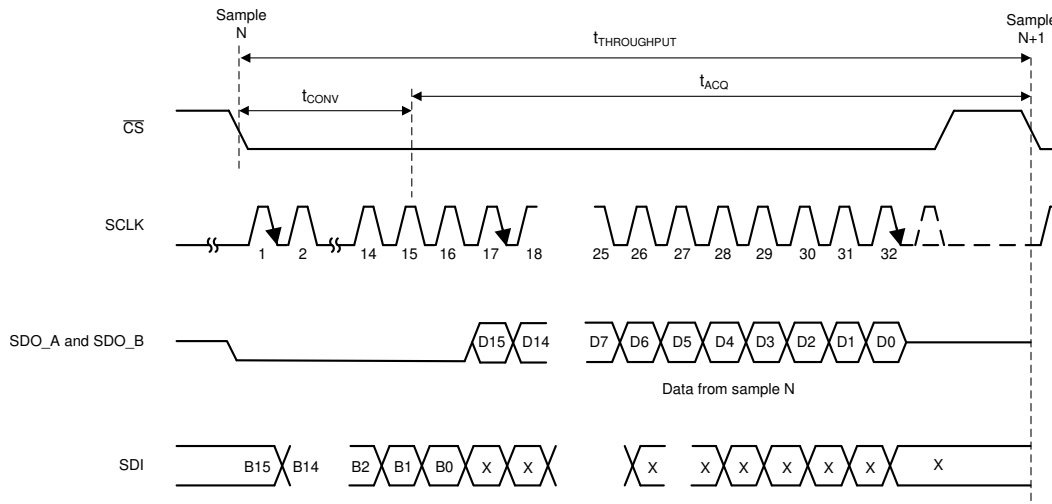

**Figure 7-6. 32-CLK, Dual-SDO Mode Timing Diagram**

A  $\overline{CS}$  falling edge brings the serial data bus out of 3-state and also outputs a 0 on the SDO\_A and SDO\_B pins. The device converts the sampled analog input during the conversion time ( $t_{CONV}$ ). SDO\_A and SDO\_B read 0 during this period. After completing the conversion process, the sample-and-hold circuit returns to sample mode. The device outputs the MSBs of ADC\_A and ADC\_B on the SDO\_A and SDO\_B pins, respectively, on the 16th SCLK falling edge. As shown in Table 7-9, the subsequent SCLK falling edges are used to shift out the rest of the bits of the conversion result.

**Table 7-9. Data Launch Edge**

DEVICE	PINS	LAUNCH EDGE												
		$\overline{CS}$	SCLK											$\overline{CS}$
		↓	↓1	—	↓15	↓16	—	↓27	↓28	↓29	↓30	↓31	↓32 ...	↑
ADS8353-Q1	SDO-A	0	0	—	0	D15_A	—	D4_A	D3_A	D2_A	D1_A	D0_A	0 ...	Hi-Z
	SDO-B	0	0	—	0	D15_B	—	D4_B	D3_B	D2_B	D1_B	D0_B	0 ...	Hi-Z

In this mode, at least 32 SCLK falling edges must be given to validate the read or write frame. A  $\overline{CS}$  rising edge ends the frame and puts the serial bus into 3-state.

See the [Timing Requirements](#) table for timing specifications specific to this serial interface mode.

### 7.5.3.2.2 32-CLK, Single-SDO Mode (CFR.B11 = 0, CFR.B10 = 1)

The 32-CLK, single-SDO mode provides the option of using only one SDO pin (SDO\_A) to read conversion results from both ADCs (ADC\_A and ADC\_B). SDO\_B remains in 3-state and can be treated as a no connect (NC) pin.

This mode can be selected by writing CFR.B11 = 0 and CFR.B10 = 1. [Figure 7-7](#) shows a detailed timing diagram for this mode.

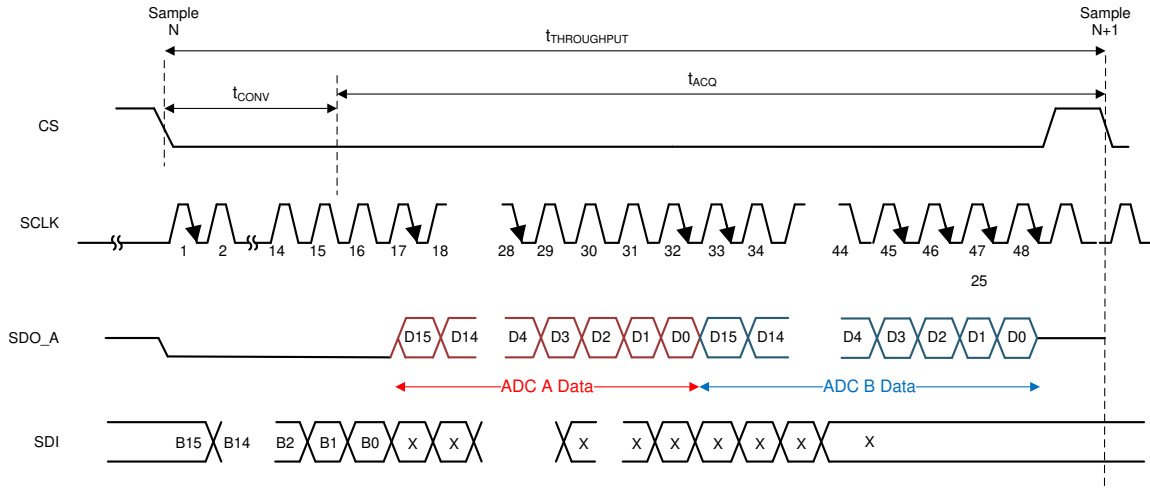

**Figure 7-7. 32-CLK, Single-SDO Mode Timing Diagram**

A  $\overline{CS}$  falling edge brings the serial data bus out of 3-state and also outputs a 0 on the SDO\_A pin. The device converts the sampled analog input during the conversion time ( $t_{CONV}$ ). SDO\_A reads 0 during this period. After completing the conversion process, the sample-and-hold circuit goes back into sample mode. The device outputs the MSB of ADC\_A on the SDO\_A pin on the 16th SCLK falling edge. As shown in [Table 7-10](#), the subsequent SCLK falling edges are used to shift out the conversion result of ADC\_A followed by the conversion result of ADC\_B on the SDO\_A pin.

**Table 7-10. Data Launch Edge**

DEVICE	PIN	LAUNCH EDGE																			
		$\overline{CS}$	SCLK																	$\overline{CS}$	
		↓	↓1	—	↓15	↓16	—	↓27	↓28	↓29	↓30	↓31	↓32	—	↓43	↓44	↓45	↓46	↓47	↓48 ...	↑
ADS8353-Q1	SDO_A	0	0	—	0	D15_A	—	D4_A	D3_A	D2_A	D1_A	D0_A	D15_B	—	D4_B	D3_B	D2_B	D1_B	D0_B	0 ...	Hi-Z

In this mode, at least 48 SCLK falling edges must be given to validate the read or write frame. A  $\overline{CS}$  rising edge ends the frame and puts the serial bus into 3-state.

See the [Timing Requirements](#) table for timing specifications specific to this serial interface mode.

### 7.5.4 Low-Power Modes

In normal mode of operation, all internal circuits of the device are always powered up and the device is always ready to commence a new conversion. This mode enables the device to support the rated throughput. The device also supports two low-power modes to optimize the power consumption at lower throughputs: STANDBY mode and software power-down (SPD) mode.

### 7.5.4.1 STANDBY Mode

The device supports a STANDBY mode of operation where some of the internal circuits of the device are powered down. However, if bit 6 in configuration register is set to 1 (CFR.B6 = 1), then the internal reference is not powered down and the contents of the REFDAC\_A and REFDAC\_B registers are retained to enable faster power-up to a normal mode of operation.

As shown in Figure 7-8, a valid write operation in frame (F) programs the configuration register with B5 set to 1 (CFR.B5 = 1) and places the device into a STANDBY mode of operation on the following  $\overline{CS}$  rising edge. While in STANDBY mode, SDO\_A and SDO\_B output all 1s when  $\overline{CS}$  is low and remain in 3-state when  $\overline{CS}$  is high.

To remain in STANDBY mode, SDI must remain low in the subsequent frames.

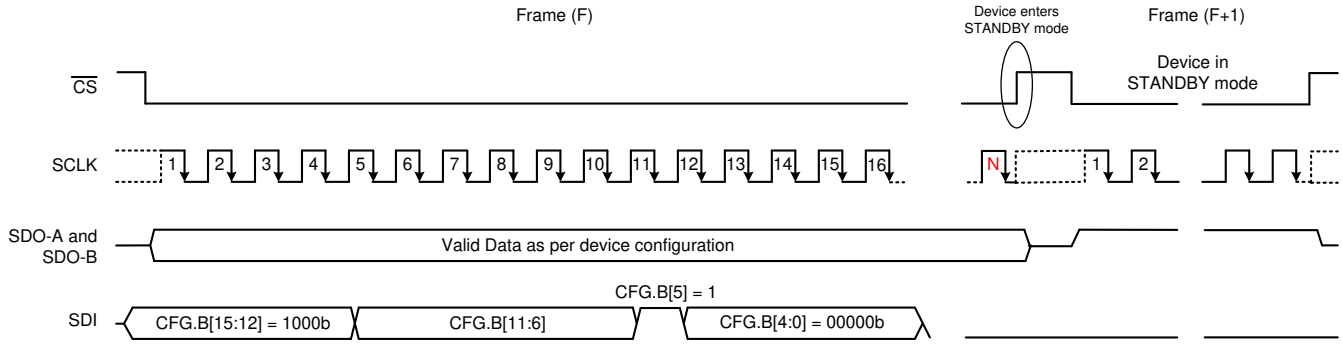

N is a function of the device configuration, as described in Table 7-4.

Figure 7-8. Enter STANDBY Mode

As shown in Figure 7-9, a valid write operation in frame (F+3) writes the configuration register with B5 set to 0 (CFR.B5 = 0) and brings the device out of STANDBY mode on the following  $\overline{CS}$  rising edge. Frame (F+3) must have at least 48 SCLK falling edges.

After exiting the STANDBY mode, a delay of  $t_{PU\_STDBY}$  must elapse for the internal circuits to fully power-up and resume normal operation in frame (F+4). Device configuration for frame (F+4) is determined by the status of the CFR.B[11:6] bits programmed during frame (F+3).

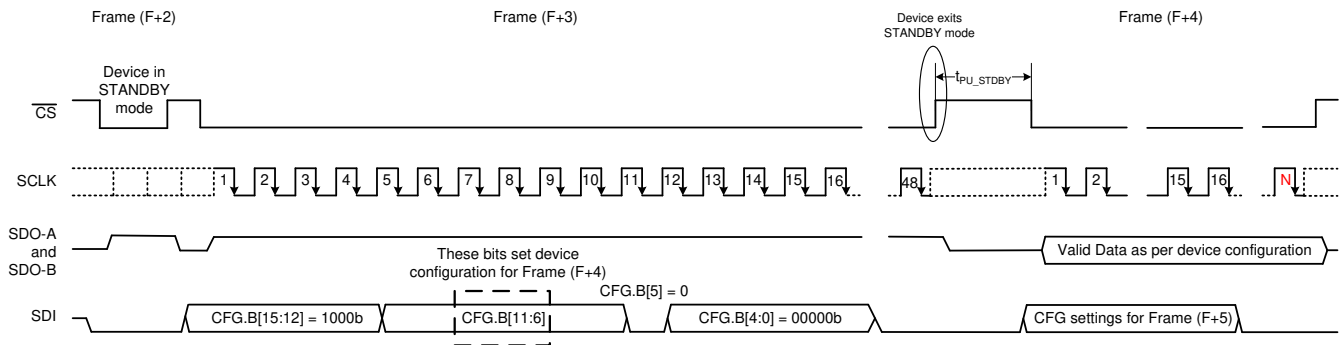

N is a function of the device configuration, as described in Table 7-4.

Figure 7-9. Exit STANDBY Mode

See the [Timing Requirements](#) table for timing specifications for this operating mode.



### 7.5.4.2 Software Power-Down (SPD) Mode

In software power-down (SPD) mode, all internal circuits (including the internal references) are powered down. However, the contents of the REFDAC\_A and REFDAC\_B registers are retained.

As shown in Figure 7-10, to enter SPD mode, the device must be selected (by bringing  $\overline{CS}$  low) and SDI must be kept high for a minimum of 48 SCLK cycles during frame (F). The device goes to SPD on the  $\overline{CS}$  rising edge following frame (F). While in SPD mode, SDO\_A and SDO\_B go to 3-state irrespective of the status of the  $\overline{CS}$  signal.

To remain in SPD mode, SDI must remain high in all subsequent frames.

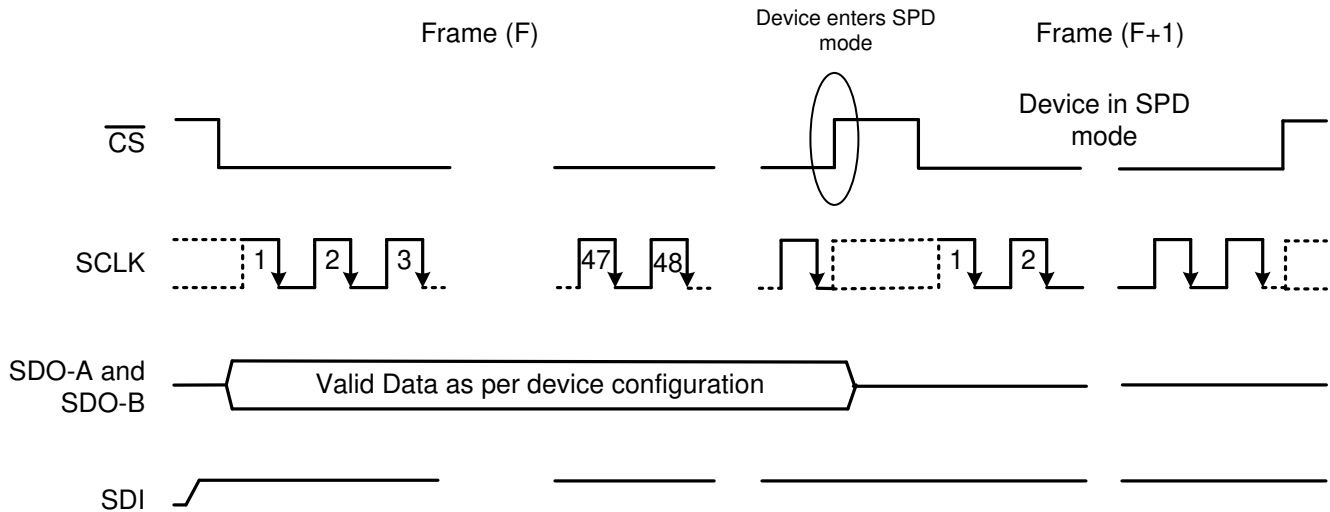
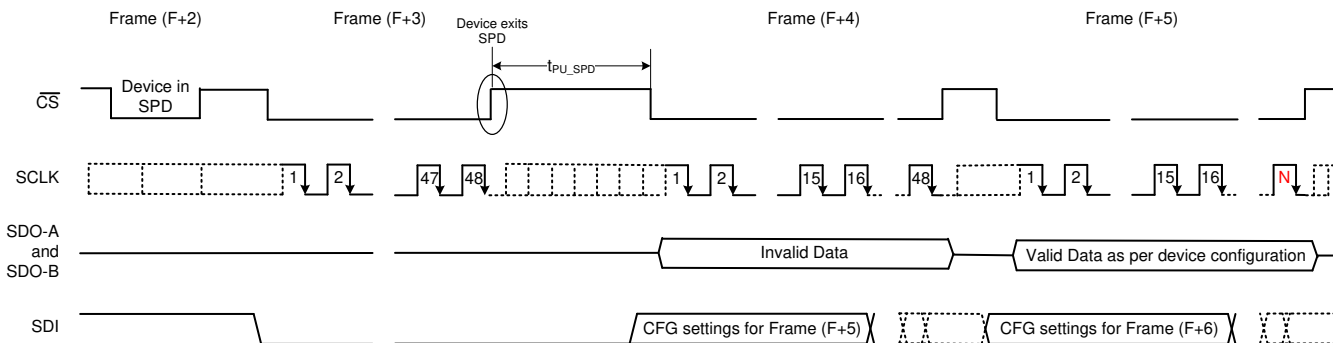

Figure 7-10. Enter SPD Mode

As shown in Figure 7-11, to exit SPD mode, the device must be selected (by bringing  $\overline{CS}$  low) and SDI must be kept low for a minimum of 48 SCLK cycles during frame (F+3). The device starts powering-up on a  $\overline{CS}$  rising edge following frame (F+3). After frame (F+3), a delay of  $t_{PU\_SPD}$  must elapse before programming the configuration register.

A valid write operation in frame (F+4) sets the device configuration for frame (F+5). Frame (F+4) must have at least 48 SCLK falling edges. Discard the output data in frame (F+4).



N is a function of the device configuration, as described in Table 7-4.

Figure 7-11. Exit SPD Mode

See the [Timing Requirements](#) table for timing specifications for this operating mode.

### 7.5.5 Frame Abort, Reconversion, or Short-Cycling

As shown in [Figure 7-12](#), the minimum number of SCLK falling edges ( $N$ ) that must be provided between the beginning and end of the frame depends on the serial interface mode. The SCLK falling edges ( $N$ ) program the device and retrieve the conversion result. If  $\overline{CS}$  is brought high before the expected number of SCLK falling edges are provided, the current frame is aborted and the device starts sampling the new analog input signal.

If frame ( $F$ ) is aborted, then the register write operation attempted in frame ( $F$ ) is considered invalid and the internal registers are not updated. The device continues to have the same configuration in frame ( $F+1$ ) from frame ( $F$ ).

The output data bits latched before the  $\overline{CS}$  rising edge are still valid data that correspond to sample  $N$ .

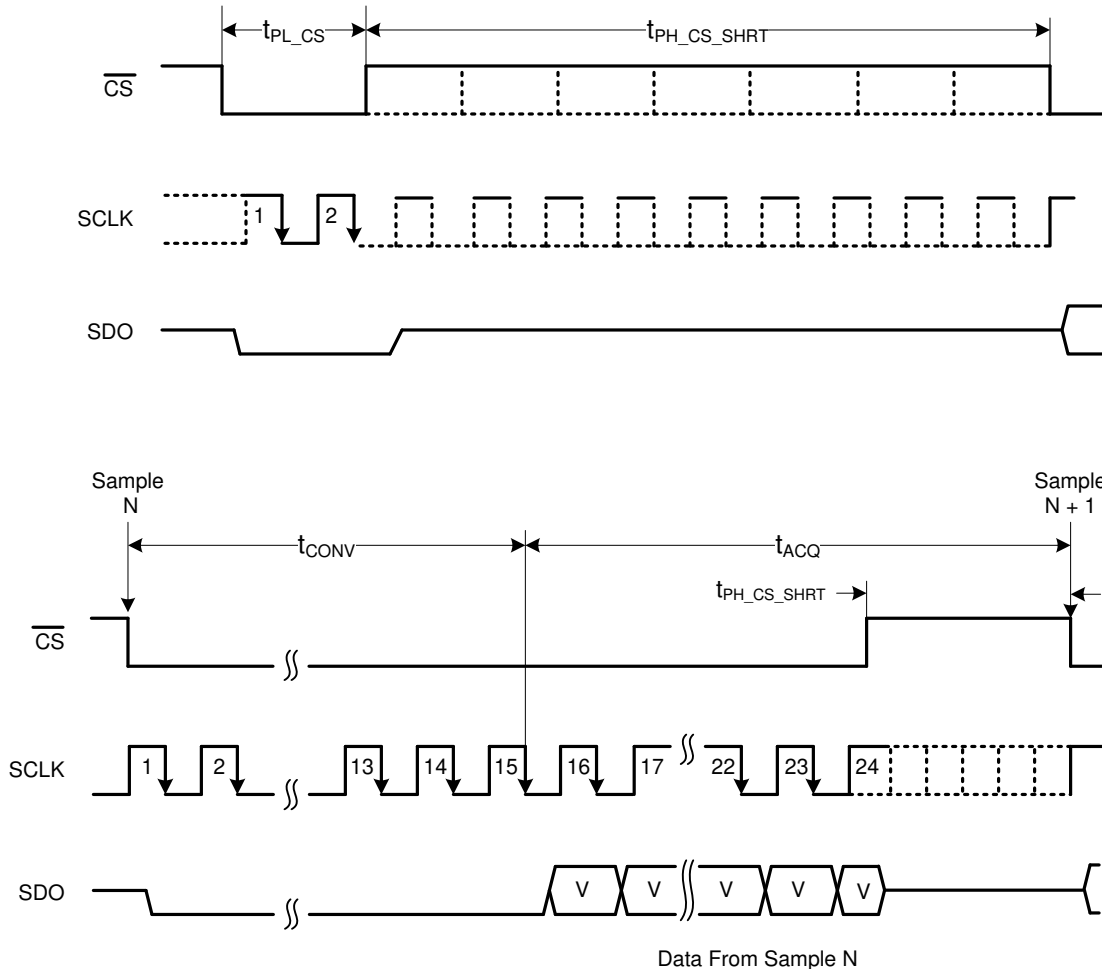

**Figure 7-12. Frame Abort, Reconversion, or Short-Cycling Feature**

See the [Timing Requirements](#) table for timing specifications for this operating mode.

## 7.6 Register Maps

### 7.6.1 ADS8353-Q1 Registers

Table 7-11 lists the memory-mapped registers for the ADS8353-Q1 registers. Consider any register offset addresses not listed in Table 7-11 as reserved locations and, therefore, do not modify the register contents.

**Table 7-11. ADS8353-Q1 Registers**

Offset	Acronym	Register Name	Section
0h	CFR	CFR register	<a href="#">Section 7.6.1.1</a>
2h	REFDAC	REFDAC register	<a href="#">Section 7.6.1.2</a>

Complex bit access types are encoded to fit into small table cells. Table 7-12 shows the codes that are used for access types in this section.

**Table 7-12. ADS8353-Q1 Access Type Codes**

Access Type	Code	Description
Read Type		
R	R	Read
Write Type		
W	W	Write
Reset or Default Value		
-n		Value after reset or the default value

### 7.6.1.1 CFR Register (Offset = 0h) [reset = 0h]

CFR is shown in [Figure 7-9](#) and described in [Table 7-13](#).

Return to [Table 7-11](#).

**Figure 7-13. CFR Register**

15		14		13		12		11		10		9		8	
WRITE_READ_CFR[3:0]								RD_CLK_MODE	RD_DATA_LINES	INPUT_RANGE	RESERVED				
R/W-0000b								R/W-0b	R/W-0b	R/W-0b	R/W-0b		R/W-0b		
7		6		5		4		3		2		1		0	
INM_SEL	REF_SEL	STANDBY	RD_DATA_FORMAT	0[3:0]											
R/W-0b	R/W-0b	W-0b	R/W-0b	R/W-0000b											

**Table 7-13. CFR Register Field Descriptions**

Bit	Field	Type	Reset	Description
15-12	WRITE_READ_CFR[3:0]	R/W	0000b	These bits select the user-programmable register.  0011b = Select this combination to read the CFR register  1000b = Select this combination to write to CFR register and enable bits 11:0
11	RD_CLK_MODE	R/W	0b	This bit must be set to 0 (default).
10	RD_DATA_LINES	R/W	0b	This bit provides data line selection for the serial interface.  0b = Use SDO_A to output ADC_A data and SDO_B to output of ADC_B data (default)  1b = Use only SDO_A to output of ADC_A data followed by ADC_B data
9	INPUT_RANGE	R/W	0b	This bit selects the maximum input range for the ADC as a function of the reference voltage provided to the ADC. See the <a href="#">Analog Inputs</a> section for more details.  0b = FSR equals $V_{REF}$  1b = FSR equals $2 \times V_{REF}$
8	RESERVED	R/W	0b	This bit must be set to 0 (default).
7	INM_SEL	R/W	0b	This bit selects the voltage to be externally connected to the INM pin.  0b = INM must be externally connected to the GND potential (default)  1b = INM must be externally connected to the FSR_ADC_x / 2
6	REF_SEL	R/W	0b	This bit selects the ADC reference voltage source. See the <a href="#">Reference</a> section for more details.  0b = Use external reference (default)  1b = Use internal reference
5	STANDBY	W	0b	This bit is used by the device to enter or exit STANDBY mode. See the <a href="#">STANDBY Mode</a> section for more details.

**Table 7-13. CFR Register Field Descriptions (continued)**

Bit	Field	Type	Reset	Description
4	RD_DATA_FORMAT	R/W	0b	This bit selects the output data format. 0b = Output is in straight binary format (default) 1b = Output is in two's complement format
3-0	0[3:0]	R/W	0000b	These bits must be set to 0 (default).

### 7.6.1.2 REFDAC Register (Offset = 2h) [reset = 0h]

REFDAC is shown in [Figure 7-10](#) and described in [Table 7-14](#).

Return to [Table 7-11](#).

**Figure 7-14. REFDAC Register**

15	14	13	12	11	10	9	8
WRITE_READ_REFDAC[3:0]				D[8:0]			
R/W-0000b				R/W-000000000b			
7	6	5	4	3	2	1	0
D[8:0]				RESERVED			
R/W-000000000b				R/W-000b			

**Table 7-14. REFDAC Register Field Descriptions**

Bit	Field	Type	Reset	Description
15-12	WRITE_READ_REFDAC[3:0]	R/W	0000b	These bits select the configurable register address. 1001 = Select this combination to write to the REFDAC_A register 1010 = Select this combination to write to the REFDAC_B register
11-3	D[8:0]	R/W	000000000b	Data to program the individual DAC output voltage. These bits are valid only for bits 15:12 = 1001 or bits 15:12 = 1010. <a href="#">Table 7-15</a> shows the relationship between the REFDAC_x programmed value and the DAC_x output voltage.
2-0	RESERVED	R/W	000b	This bit must be set to 0 (default).

**Table 7-15. REFDAC Settings**

REFDAC_x VALUE (Bits 11:3 in Hex)	B[2:0]	Typical DAC_x OUTPUT VOLTAGE (V) <sup>(1)</sup>
1FF (default)	000	2.5000
1FE	000	2.4989
1FD	000	2.4978
—	—	—
1D7	000	2.45
—	—	—
1AE	000	2.40
—	—	—
186	000	2.35
—	—	—
15D	000	2.30
—	—	—
134	000	2.25
—	—	—
10C	000	2.20
—	—	—
0E3	000	2.15

**Table 7-15. REFDAC Settings (continued)**

REFDAC_x VALUE (Bits 11:3 in Hex)	B[2:0]	Typical DAC_x OUPUT VOLTAGE (V) <sup>(1)</sup>
—	—	—
0BA	000	2.10
—	—	—
091	000	2.05
—	—	—
069	000	2.00
—	—	—
064 to 000	000	Do not use

- (1) Actual output voltage may vary by a few millivolts from the specified value. To obtain the desired output voltage, TI recommends starting with the specified register setting and then experimenting with five codes on either side of the specified register setting.

## 8 Application and Implementation

### Note

Information in the following applications sections is not part of the TI component specification, and TI does not warrant its accuracy or completeness. TI's customers are responsible for determining suitability of components for their purposes, as well as validating and testing their design implementation to confirm system functionality.

### 8.1 Application Information

The two primary circuits required to maximize the performance of a high-precision, successive approximation register (SAR), analog-to-digital converter (ADC) are the input driver and the reference driver circuits. This section details some general principles for designing these circuits, and some application circuits designed using these devices.

The device supports operation either with an internal or external reference source. See the [Reference](#) section for details about the decoupling requirements.

The reference source to the ADC must provide low-drift and very accurate dc voltage and support the dynamic charge requirements without affecting the noise and linearity performance of the device. The output broadband noise (typically in the order of a few 100  $\mu\text{V}_{\text{RMS}}$ ) of the reference source must be appropriately filtered by using a low-pass filter with a cutoff frequency of a few hundred hertz. After band-limiting the noise from the reference source, the next important step is to design a reference buffer that can drive the dynamic load posed by the reference input of the ADC. At the start of each conversion, the reference buffer must regulate the voltage of the reference pin within 1 LSB of the intended value. This condition necessitates the use of a large filter capacitor at the reference pin of the ADC. The amplifier selected to drive the reference input pin must be stable while driving this large capacitor and must have low output impedance, low offset, and temperature drift specifications. To reduce the dynamic current requirements and crosstalk between the channels, a separate reference buffer is recommended for driving the reference input of each ADC channel.

The input driver circuit for a high-precision ADC mainly consists of two parts: a driving amplifier and a fly-wheel RC filter. The amplifier is used for signal conditioning of the input voltage and its low output impedance provides a buffer between the signal source and the switched capacitor inputs of the ADC. The RC filter helps attenuate the sampling charge injection from the switched-capacitor input stage of the ADC and functions as a charge kickback filter to band-limit the wideband noise contributed by the front-end circuit. Careful design of the front-end circuit is critical to meet the linearity and noise performance of a high-precision ADC.

#### 8.1.1 Input Amplifier Selection

Selection criteria for the input amplifiers is highly dependent on the input signal type and the performance goals of the data acquisition system. Some key amplifier specifications to consider while selecting an appropriate amplifier to drive the inputs of the ADC are:

- *Small-signal bandwidth.* Select the small-signal bandwidth of the input amplifiers to be as high as possible after meeting the power budget of the system. Higher bandwidth reduces the closed-loop output impedance of the amplifier, thus allowing the amplifier to more easily drive the low cutoff frequency RC filter at the ADC inputs. Higher bandwidth also minimizes the harmonic distortion at higher input frequencies. Select the amplifier bandwidth as described in [Equation 6](#) to maintain the overall stability of the input driver circuit:

$$\text{Unity - Gain Bandwidth} \geq 4 \times \left( \frac{1}{2\pi \times (R_{FLT} + R_{FLT}) \times C_{FLT}} \right) \quad (6)$$

- *Noise.* Noise contribution of the front-end amplifiers must be as low as possible to prevent any degradation in SNR performance of the system. As a rule of thumb, to ensure that the noise performance of the data acquisition system is not limited by the front-end circuit, keep the total noise contribution from the front-end circuit below 20% of the input-referred noise of the ADC. [Equation 7](#) calculates noise from the input driver circuit. This noise is band-limited by designing a low cutoff frequency RC filter:

$$N_G \times \sqrt{2} \times \sqrt{\left(\frac{V_{1/f\_AMP\_PP}}{6.6}\right)^2 + e_{n\_RMS}^2 \times \frac{\pi}{2} \times f_{-3dB}} \leq \frac{1}{5} \times \frac{V_{REF}}{\sqrt{2}} \times 10^{-\left(\frac{SNR(dB)}{20}\right)} \quad (7)$$

where:

- $V_{1/f\_AMP\_PP}$  = the peak-to-peak flicker noise in  $\mu V$
- $e_{n\_RMS}$  = the amplifier broadband noise density in  $nV/\sqrt{Hz}$
- $f_{-3dB}$  = the 3-dB bandwidth of the RC filter
- $N_G$  = the noise gain of the front-end circuit, which is equal to 1 in a buffer configuration
- **Distortion.** Both the ADC and the input driver introduce nonlinearity in a data acquisition block. As a rule of thumb, the distortion of the input driver must be at least 10 dB lower than the distortion of the ADC, as shown in Equation 8, to ensure that the distortion performance of the data acquisition system is not limited by the front-end circuit.

$$THD_{AMP} \leq THD_{ADC} - 10 \text{ (dB)} \quad (8)$$

- **Settling Time.** For dc signals with fast transients that are common in a multiplexed application, the input signal must settle to the desired accuracy at the inputs of the ADC during the acquisition time window. This condition is critical to maintain the overall linearity performance of the ADC. Typically, the amplifier data sheets specify the output settling performance only up to 0.1% to 0.001%, which may not be sufficient for the desired accuracy. Therefore, always verify the settling behavior of the input driver with TINA™-SPICE simulations before selecting the amplifier.

### 8.1.2 Charge Kickback Filter

Converting analog-to-digital signals requires sampling an input signal at a constant rate. Any higher frequency content in the input signal beyond half the sampling frequency is digitized and folded back into the low-frequency spectrum. This process is called *aliasing*. Therefore, an analog, charge kickback filter must be used to remove the harmonic content from the input signal before being sampled by the ADC. A charge kickback filter is designed as a low-pass, RC filter, for which the 3-dB bandwidth is optimized based on specific application requirements. For dc signals with fast transients (including multiplexed input signals), a high-bandwidth filter is designed to allow accurately settling the signal at the ADC inputs during the small acquisition time window. For ac signals, keep the filter bandwidth low to band-limit the noise fed into the ADC input, thereby increasing the signal-to-noise ratio (SNR) of the system.

A filter capacitor,  $C_{FLT}$ , connected across the ADC inputs (see Figure 8-1), filters the noise from the front-end drive circuitry, reduces the sampling charge injection, and provides a charge bucket to quickly charge the internal sample-and-hold capacitors during the acquisition process. As a rule of thumb, the value of this capacitor must be at least 10 times the specified value of the ADC sampling capacitance. For these devices, the input sampling capacitance is equal to 40 pF. Thus, the value of  $C_{FLT}$  must be greater than 400 pF. The capacitor must be a COG- or NPO-type because these capacitor types have a high-Q, low-temperature coefficient, and stable electrical characteristics under varying voltages, frequency, and time.

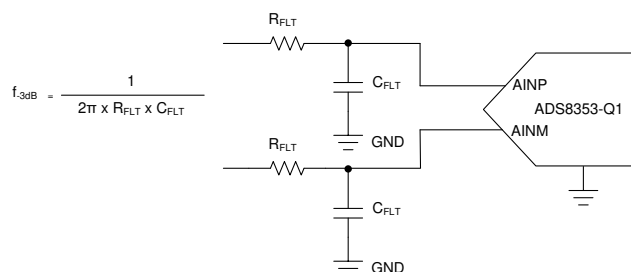

**Figure 8-1. Charge Kickback Filter**

Driving capacitive loads can degrade the phase margin of the input amplifiers, thus making the amplifier marginally unstable. To avoid amplifier stability issues, series isolation resistors ( $R_{FLT}$ ) are used at the output



of the amplifiers. A higher value of  $R_{FLT}$  is helpful from the amplifier stability perspective, but adds distortion as a result of interactions with the nonlinear input impedance of the ADC. Distortion increases with source impedance, input signal frequency, and input signal amplitude. Therefore, the selection of  $R_{FLT}$  requires balancing the stability and distortion of the design. For more information on ADC input R-C filter component selection, see the [TI Precision Labs](#) on ti.com.

## 8.2 Typical Application

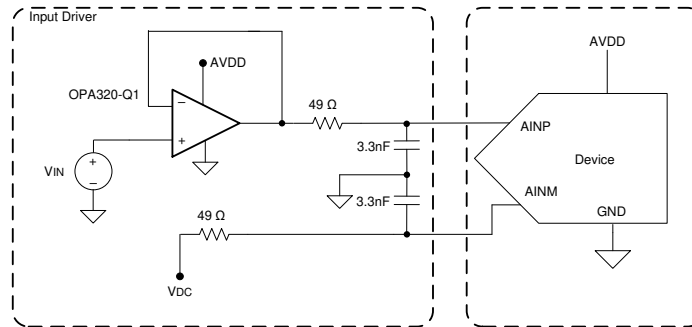

Only one ADC channel is shown in this diagram. Replicate the same circuit for other ADC channels.

**Figure 8-2. DAQ Circuit: Maximum SINAD for a 10-kHz Input Signal at Full Throughput, 32-CLK Interface**

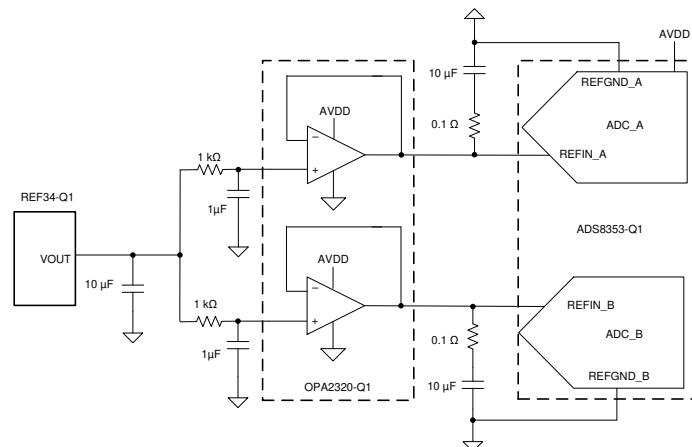

**Figure 8-3. Reference Drive Circuit**

### 8.2.1 Design Requirements

Table 8-1 lists the target specifications for this application.

**Table 8-1. Target Specifications**

TARGET SPECIFICATIONS		TEST CONDITIONS			
SNR	THD	DEVICE	INPUT SIGNAL FREQUENCY	THROUGHPUT	INTERFACE MODE
> 83 dB	< -100 dB	ADS8353-Q1	10 kHz	Maximum supported	32-CLK, dual-SDO

### 8.2.2 Detailed Design Procedure

Best practice is for the distortion from the input driver to be at least 10 dB less than the ADC distortion. The distortion resulting from variation in the common-mode signal is eliminated by using the amplifier in an inverting gain configuration that establishes a fixed common-mode level for the circuit. This configuration also eliminates the requirement of rail-to-rail swing at the amplifier input. The low-power [OPA320-Q1](#), used as an input driver, provides exceptional ac performance because of its extremely low-distortion and high-bandwidth specifications. In addition, the components of the antialiasing filter are such that the noise from the front-end circuit is kept low without adding distortion to the input signal.

The application circuit illustrated in [Figure 8-2](#) is optimized to achieve the lowest distortion and lowest noise for a 10-kHz input signal fed to the ADS8353-Q1 operating at full throughput with the default 32-CLK, dual-SDO interface mode. The input signal is processed through a high-bandwidth, low-distortion amplifier in an inverting gain configuration and a low-pass RC filter before being fed into the device.

[Figure 8-3](#) illustrates the reference driver circuit when operation with an external reference is desired. The reference voltage is generated by the high-precision, low-noise [REF34-Q1](#) circuit. The output broadband noise of the reference is heavily filtered by a low-pass filter with a 3-dB cutoff frequency of 160 Hz. The decoupling capacitor on each reference pin is selected to be 10  $\mu$ F. The low output impedance, low noise, and fast settling time make the [OPA2320-Q1](#) a good choice for driving this high capacitive load.

### 8.2.3 Application Curve

To minimize external components and to maximize the dynamic range of the ADC, the device is configured to operate with internal reference (CFR.B6 = 1) and  $2 \times V_{REF\_X}$  input full-scale range (CFR.B9 = 1).

[Figure 8-4](#) shows the FFT plot and test result obtained with the ADS8353-Q1 operating at full throughput with a 32-CLK interface and the circuit configuration of [Figure 8-2](#).

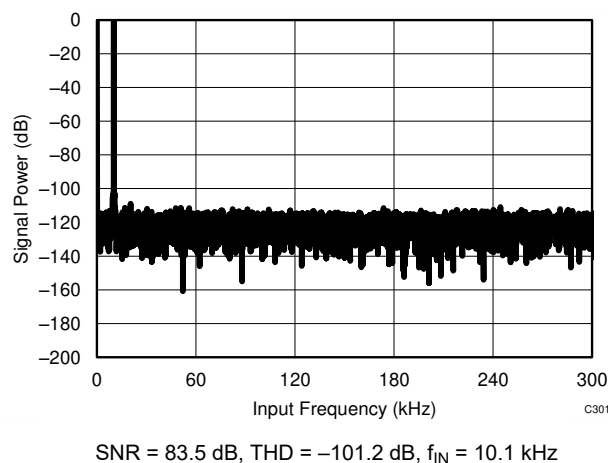

**Figure 8-4. ADS8353-Q1 in 32-CLK Interface Mode**

## 8.3 Power Supply Recommendations

The device has two separate power supplies: AVDD and DVDD. The device operates on AVDD; DVDD is used for the interface circuits. AVDD and DVDD can be independently set to any value within the permissible ranges.

When using the device with the  $2 \times V_{REF}$  input range (CFR.B9 = 1), the AVDD supply voltage value defines the permissible voltage swing on the analog input pins. AVDD must be set as shown in [Equation 9](#), [Equation 10](#), and [Equation 11](#) to avoid saturation of output codes and to use the full dynamic range on the analog input pins:

$$AVDD \geq 2 \times V_{REF\_A} \quad (9)$$

$$AVDD \geq 2 \times V_{REF\_B} \quad (10)$$

$$4.75 \text{ V} \leq AVDD \leq 5.25 \text{ V} \quad (11)$$

Decouple the AVDD and DVDD pins, as shown in [Figure 8-5](#), with the GND pin using individual 10- $\mu$ F decoupling capacitors.

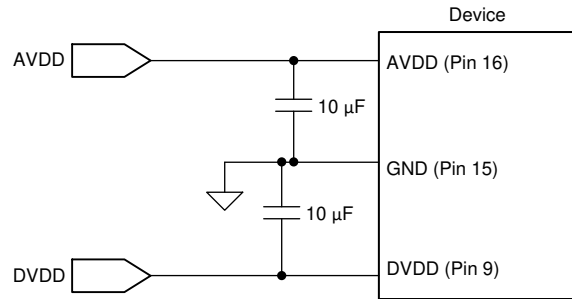

**Figure 8-5. Power-Supply Decoupling**

## 8.4 Layout

### 8.4.1 Layout Guidelines

Figure 8-6 shows a board layout example for the ADS8353-Q1 TSSOP package. Partition the printed circuit board (PCB) into analog and digital sections. Avoid crossing digital lines with the analog signal path and keep the analog input signals and the reference input signals away from noise sources. As shown in Figure 8-6, the analog input and reference signals are routed on the left side of the board and the digital connections are routed on the right side of the device.

The power sources to the device must be clean and well-bypassed. Use 10- $\mu$ F, ceramic bypass capacitors in close proximity to the analog (AVDD) and digital (DVDD) power-supply pins. Avoid placing vias between the AVDD and DVDD pins and the bypass capacitors. Connect all ground pins to the ground plane using short, low impedance paths.

The REFIO-A and REFIO-B reference inputs and outputs are bypassed with 10- $\mu$ F, X7R-grade, 0805-size, 16-V rated ceramic capacitors ( $C_{REF-x}$ ). Place the reference bypass capacitors as close as possible to the reference REFIO-x pins and connect the bypass capacitors using short, low-inductance connections. Avoid placing vias between the REFIO-x pins and the bypass capacitors. Small 0.1- $\Omega$  to 0.2- $\Omega$  resistors ( $R_{REF-x}$ ) are used in series with the reference bypass capacitors to improve stability.

The fly-wheel RC filters are placed immediately next to the input pins. Among ceramic surface-mount capacitors, COG (NPO) ceramic capacitors provide the best capacitance precision. The type of dielectric used in COG (NPO) ceramic capacitors provides the most stable electrical properties over voltage, frequency, and temperature changes. Figure 8-6 shows  $C_{IN-A}$  and  $C_{IN-B}$  filter capacitors placed across the analog input pins of the device.

### 8.4.2 Layout Example

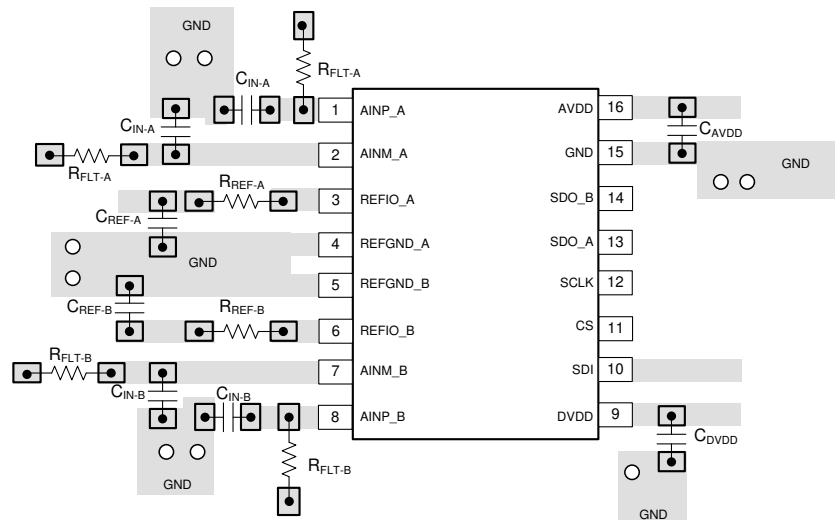

**Figure 8-6. Recommended Layout**

## 9 Device and Documentation Support

### 9.1 Device Support

#### 9.1.1 Development Support

Texas Instruments, [TI Precision Labs TI training and videos site](#)

### 9.2 Documentation Support

#### 9.2.1 Related Documentation

For related documentation see the following:

- Texas Instruments, [OPAx320-Q1 Precision, 20-MHz, 0.9-pA, low-noise, RRIO, CMOS operational amplifier data sheet](#)
- Texas Instruments, [REF34-Q1 Low-drift, low-power, small-footprint series voltage references data sheet](#)

### 9.3 Receiving Notification of Documentation Updates

To receive notification of documentation updates, navigate to the device product folder on [ti.com](#). Click on [Subscribe to updates](#) to register and receive a weekly digest of any product information that has changed. For change details, review the revision history included in any revised document.

### 9.4 Support Resources

[TI E2E™ support forums](#) are an engineer's go-to source for fast, verified answers and design help — straight from the experts. Search existing answers or ask your own question to get the quick design help you need.

Linked content is provided "AS IS" by the respective contributors. They do not constitute TI specifications and do not necessarily reflect TI's views; see TI's [Terms of Use](#).

### 9.5 Trademarks

TINA™ and TI E2E™ are trademarks of Texas Instruments. All trademarks are the property of their respective owners.

### 9.6 Electrostatic Discharge Caution



This integrated circuit can be damaged by ESD. Texas Instruments recommends that all integrated circuits be handled with appropriate precautions. Failure to observe proper handling and installation procedures can cause damage.

ESD damage can range from subtle performance degradation to complete device failure. Precision integrated circuits may be more susceptible to damage because very small parametric changes could cause the device not to meet its published specifications.

### 9.7 Glossary

[TI Glossary](#) This glossary lists and explains terms, acronyms, and definitions.

### Mechanical, Packaging, and Orderable Information

The following pages include mechanical, packaging, and orderable information. This information is the most current data available for the designated devices. This data is subject to change without notice and revision of this document. For browser-based versions of this data sheet, refer to the left-hand navigation.

**PACKAGING INFORMATION**

Orderable Device	Status (1)	Package Type	Package Drawing	Pins	Package Qty	Eco Plan (2)	Lead finish/ Ball material (6)	MSL Peak Temp (3)	Op Temp (°C)	Device Marking (4/5)	Samples
ADS8353QPWQ1	ACTIVE	TSSOP	PW	16	90	RoHS & Green	NIPDAU	Level-2-260C-1 YEAR	-40 to 125	A8353Q	<a href="#">Samples</a>
ADS8353QPWRQ1	ACTIVE	TSSOP	PW	16	2000	RoHS & Green	NIPDAU	Level-2-260C-1 YEAR	-40 to 125	A8353Q	<a href="#">Samples</a>

(1) The marketing status values are defined as follows:

**ACTIVE:** Product device recommended for new designs.

**LIFEBUY:** TI has announced that the device will be discontinued, and a lifetime-buy period is in effect.

**NRND:** Not recommended for new designs. Device is in production to support existing customers, but TI does not recommend using this part in a new design.

**PREVIEW:** Device has been announced but is not in production. Samples may or may not be available.

**OBSOLETE:** TI has discontinued the production of the device.

(2) **RoHS:** TI defines "RoHS" to mean semiconductor products that are compliant with the current EU RoHS requirements for all 10 RoHS substances, including the requirement that RoHS substance do not exceed 0.1% by weight in homogeneous materials. Where designed to be soldered at high temperatures, "RoHS" products are suitable for use in specified lead-free processes. TI may reference these types of products as "Pb-Free".

**RoHS Exempt:** TI defines "RoHS Exempt" to mean products that contain lead but are compliant with EU RoHS pursuant to a specific EU RoHS exemption.

**Green:** TI defines "Green" to mean the content of Chlorine (Cl) and Bromine (Br) based flame retardants meet JS709B low halogen requirements of <=1000ppm threshold. Antimony trioxide based flame retardants must also meet the <=1000ppm threshold requirement.

(3) MSL, Peak Temp. - The Moisture Sensitivity Level rating according to the JEDEC industry standard classifications, and peak solder temperature.

(4) There may be additional marking, which relates to the logo, the lot trace code information, or the environmental category on the device.

(5) Multiple Device Markings will be inside parentheses. Only one Device Marking contained in parentheses and separated by a "~" will appear on a device. If a line is indented then it is a continuation of the previous line and the two combined represent the entire Device Marking for that device.

(6) Lead finish/Ball material - Orderable Devices may have multiple material finish options. Finish options are separated by a vertical ruled line. Lead finish/Ball material values may wrap to two lines if the finish value exceeds the maximum column width.

**Important Information and Disclaimer:**The information provided on this page represents TI's knowledge and belief as of the date that it is provided. TI bases its knowledge and belief on information provided by third parties, and makes no representation or warranty as to the accuracy of such information. Efforts are underway to better integrate information from third parties. TI has taken and continues to take reasonable steps to provide representative and accurate information but may not have conducted destructive testing or chemical analysis on incoming materials and chemicals. TI and TI suppliers consider certain information to be proprietary, and thus CAS numbers and other limited information may not be available for release.

In no event shall TI's liability arising out of such information exceed the total purchase price of the TI part(s) at issue in this document sold by TI to Customer on an annual basis.

**OTHER QUALIFIED VERSIONS OF ADS8353-Q1 :**

- Catalog : [ADS8353](#)

## NOTE: Qualified Version Definitions:

- Catalog - TI's standard catalog product

**TAPE AND REEL INFORMATION**

**QUADRANT ASSIGNMENTS FOR PIN 1 ORIENTATION IN TAPE**

\*All dimensions are nominal

Device	Package Type	Package Drawing	Pins	SPQ	Reel Diameter (mm)	Reel Width W1 (mm)	A0 (mm)	B0 (mm)	K0 (mm)	P1 (mm)	W (mm)	Pin1 Quadrant
ADS8353QPWRQ1	TSSOP	PW	16	2000	330.0	12.4	6.9	5.6	1.6	8.0	12.0	Q1

**TAPE AND REEL BOX DIMENSIONS**

\*All dimensions are nominal

Device	Package Type	Package Drawing	Pins	SPQ	Length (mm)	Width (mm)	Height (mm)
ADS8353QPWRQ1	TSSOP	PW	16	2000	350.0	350.0	43.0



**TUBE**

\*All dimensions are nominal

Device	Package Name	Package Type	Pins	SPQ	L (mm)	W (mm)	T (μm)	B (mm)
ADS8353QPWQ1	PW	TSSOP	16	90	530	10.2	3600	3.5



4220204/A 02/2017

NOTES:

1. All linear dimensions are in millimeters. Any dimensions in parenthesis are for reference only. Dimensioning and tolerancing per ASME Y14.5M.
2. This drawing is subject to change without notice.
3. This dimension does not include mold flash, protrusions, or gate burrs. Mold flash, protrusions, or gate burrs shall not exceed 0.15 mm per side.
4. This dimension does not include interlead flash. Interlead flash shall not exceed 0.25 mm per side.
5. Reference JEDEC registration MO-153.

# EXAMPLE BOARD LAYOUT

PW0016A

TSSOP - 1.2 mm max height

SMALL OUTLINE PACKAGE



LAND PATTERN EXAMPLE  
EXPOSED METAL SHOWN  
SCALE: 10X



4220204/A 02/2017

NOTES: (continued)

- 6. Publication IPC-7351 may have alternate designs.
- 7. Solder mask tolerances between and around signal pads can vary based on board fabrication site.

# EXAMPLE STENCIL DESIGN

PW0016A

TSSOP - 1.2 mm max height

SMALL OUTLINE PACKAGE



SOLDER PASTE EXAMPLE  
BASED ON 0.125 mm THICK STENCIL  
SCALE: 10X

4220204/A 02/2017

NOTES: (continued)

8. Laser cutting apertures with trapezoidal walls and rounded corners may offer better paste release. IPC-7525 may have alternate design recommendations.
9. Board assembly site may have different recommendations for stencil design.

## IMPORTANT NOTICE AND DISCLAIMER

TI PROVIDES TECHNICAL AND RELIABILITY DATA (INCLUDING DATA SHEETS), DESIGN RESOURCES (INCLUDING REFERENCE DESIGNS), APPLICATION OR OTHER DESIGN ADVICE, WEB TOOLS, SAFETY INFORMATION, AND OTHER RESOURCES "AS IS" AND WITH ALL FAULTS, AND DISCLAIMS ALL WARRANTIES, EXPRESS AND IMPLIED, INCLUDING WITHOUT LIMITATION ANY IMPLIED WARRANTIES OF MERCHANTABILITY, FITNESS FOR A PARTICULAR PURPOSE OR NON-INFRINGEMENT OF THIRD PARTY INTELLECTUAL PROPERTY RIGHTS.

These resources are intended for skilled developers designing with TI products. You are solely responsible for (1) selecting the appropriate TI products for your application, (2) designing, validating and testing your application, and (3) ensuring your application meets applicable standards, and any other safety, security, regulatory or other requirements.

These resources are subject to change without notice. TI grants you permission to use these resources only for development of an application that uses the TI products described in the resource. Other reproduction and display of these resources is prohibited. No license is granted to any other TI intellectual property right or to any third party intellectual property right. TI disclaims responsibility for, and you will fully indemnify TI and its representatives against, any claims, damages, costs, losses, and liabilities arising out of your use of these resources.

TI's products are provided subject to [TI's Terms of Sale](#) or other applicable terms available either on [ti.com](http://ti.com) or provided in conjunction with such TI products. TI's provision of these resources does not expand or otherwise alter TI's applicable warranties or warranty disclaimers for TI products.

TI objects to and rejects any additional or different terms you may have proposed.

Mailing Address: Texas Instruments, Post Office Box 655303, Dallas, Texas 75265  
Copyright © 2022, Texas Instruments Incorporated